

SALES & ENGINEERING DATA

RATIO SERIES: **0.2:1**

FLUID P.S.I. RANGE: **10 - 278**

650950-X4X

FOUR - BALL PUMP

RELEASED: 9-25-98
 REVISED: 5-26-10
 REV. 05 S-948

DIMENSIONAL DATA

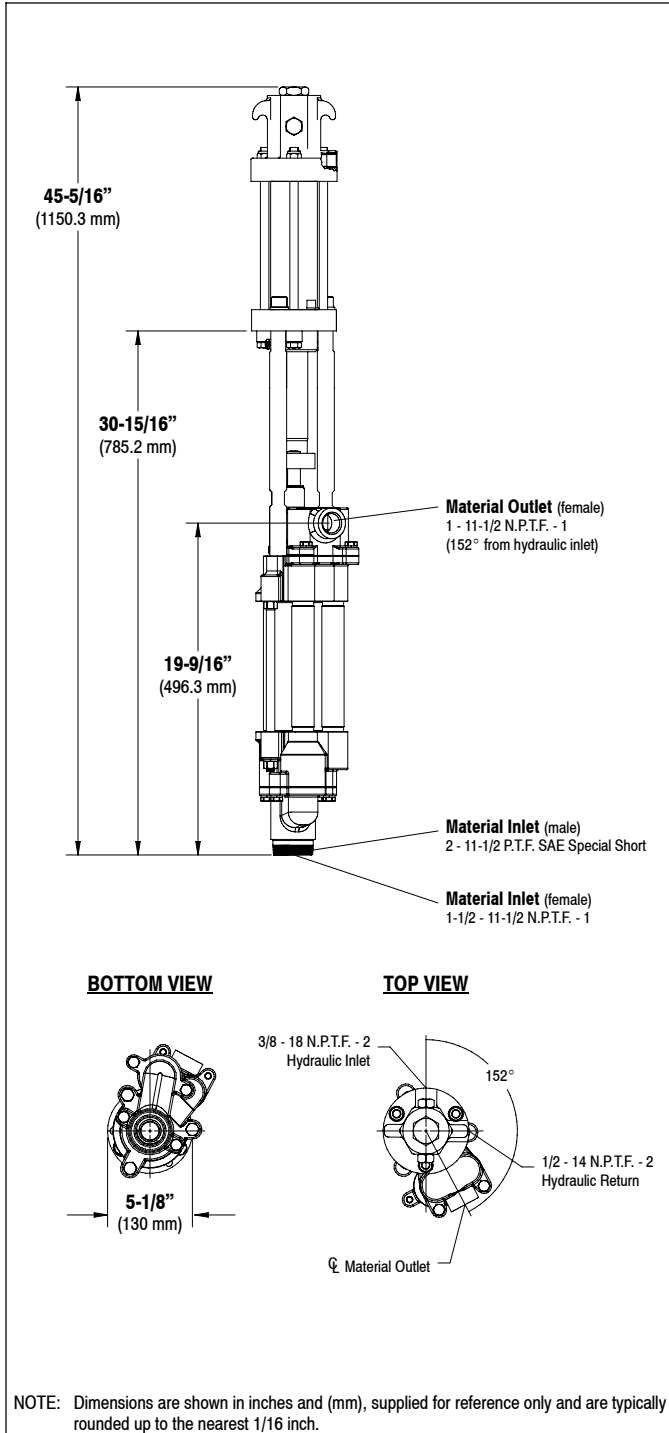

SPECIFICATIONS

CONSTRUCTION

Model Series (refer to option chart)	650950-X4X
Pump Type	Hydraulically Operated, Four-Ball, Double Acting Pump
Ratio	0.2:1
Hydraulic Motor	67147-B
Motor Repair Kit	637449
Motor Size	2.062 sq." (13.3 sq. cm)
Stroke	5.75" (14.6 cm)
Hydraulic Inlet (female)	3/8 - 18 N.P.T.F. - 2
Hydraulic Return (female)	1/2 - 14 N.P.T.F. - 2
Lower Pump End Series	67201-X4X
Lower Pump Repair Kit	637318-X4B
Packing Options:	

- 7 - PTFE
- C - UHMW-PE
- F - UHMW-PE / Leather staggered upper • UHMW-PE lower
- P - UHMW-PE / PTFE staggered upper • UHMW-PE lower
- R - PTFE / UHMW-PE staggered upper • PTFE lower

Material Inlet (female)	1-1/2 - 11-1/2 N.P.T.F. - 1
(male)	2 - 11-1/2 P.T.F. SAE spec. short
Material Outlet (female)	1 - 11-1/2 N.P.T.F. - 1

MATERIALS OF CONSTRUCTION

Outlet Body	CF-8M Stainless Steel
Cylinder (-X4B)	304 Stainless Steel, Ceramic coating
(-X43)	304 Stainless Steel, hard chrome plated
Plunger (-X4B)	17-4 Stainless Steel, Ceramic coating
(-X43)	17-4 Stainless Steel, hard chrome plated
Upper Ball	316 Stainless Steel
Upper Seat	17-4 Stainless Steel
Lower Ball	316 Stainless Steel
Lower Seat	17-4 Stainless Steel
Inlet Body	CF-8M Stainless Steel
Weight	72 lbs (32.7 kgs)

PERFORMANCE

Hydraulic Inlet Pressure Range	50 - 1200 p.s.i. (3.4 - 82.8 bar)
Fluid Pressure Range	10 - 278 p.s.i. (0.69 - 19.2 bar)
Required H-power @ 50 c.p.m.	3.2 @ 1200 p.s.i. (82.8 bar)
Hydraulic flow required @ 50 c.p.m.	4.9 g.p.m. (18.5 l.p.m.)
Maximum rec'd Cycles / Minute	50
Displacement In³ Per Cycle	103.6
Volume / Cycle	57.4 oz. (1697.2 ml)
Cycles Per Gallon	2.23
Flow @ 50 Cycles / Minute	22.4 g.p.m. (84.9 l.p.m.)
Noise Level	N / A
Maximum Temperature Limit	130° F (54° C)

ACCESSORIES:

- 61937-1 Wall Mount Bracket
- 67187-2 Mounting Post

PERFORMANCE CURVES

