

BALDOR® • ***RELIANCE***

Product Information Packet

CEDM3711T

10HP,3490RPM,3PH,60HZ,215TC,3728M,TEFC,F

Part Detail							
Revision:	B	Status:	PRD/A	Change #:		Proprietary:	No
Type:	AC	Prod. Type:	3728M	Elec. Spec:	37WGS864	CD Diagram:	CD0005
Enclosure:	TEFC	Mfg Plant:		Mech. Spec:	37N854	Layout:	37LYN854
Frame:	215TC	Mounting:	F1	Poles:	02	Created Date:	04-14-2016
Base:	RG	Rotation:	R	Insulation:	F	Eff. Date:	11-17-2016
Leads:	9#14					Replaced By:	
Literature:		Elec. Diagram:					

Nameplate NP3504E										
CAT NO	CEDM3711T									
SPEC.	37N854S864G1							ENCL	TEFC	
FRAME	215TC			HP		10				
VOLTS	230/460									
FLA	23.6/11.8					I.P.	56			
RPM	3490			RPM MAX		5400				
HZ	60			PH	3		CLASS	F		
SER.F.	1.15			DES	B		CC	010A		
NEMA-NOM-EFF	90.2									
RATING	40C AMB-CONT									
DE BRG	6307			ODE BRG		6206				
GREASE	POLYREX EM									
C HP FR	60			C HP TO		90				
CT HZ FROM	6			CT HZ TO		60				
SER.NO										
	50C AT 1.0 SF									
						VT HZ FROM	6		VT HZ TO	60

Parts List		
Part Number	Description	Quantity
SA319733	SA 37N854S864G1	1.000 EA
RA307442	RA 37N854S864G1	1.000 EA
HW3200A01	3/8-16X3/4 I-BLT WELDED F/S	1.000 EA
37CB1000A17E	37 KOBX .75 NPT @ 6:00 (E-COAT)	1.000 EA
37GS1016B01	SANTOPRENE KOBX GASKET W/LIP (BLACK)	1.000 EA
51XW2520A12	.25-20 X .75, TAPTITE II, HEX WSHR SLTD	2.000 EA
11XW1032G06	10-32 X .38, TAPTITE II, HEX WSHR SLTD U	1.000 EA
HW3001B01	BRASS CUP WASHER, FOR #8 SCREW	1.000 EA
37EP1100E37LP2	FRONT TEFC 206 BRG W/CLIPPER	1.000 EA
HA4054	SHORT T-DRAIN FITTING, .125" N.P.T.	1.000 EA
HW4606A03	JM CLIPPER/SEAL (LWE-1156-1875-AL44)	1.000 EA
HW4500A33	1/8 NPT STAINLESS,HOLO-KROME #13002,PRES	3.000 EA
HW5100A06	W2420-025 WVY WSHR (WB)	1.000 EA
37EP1300B75E	PULLEY 213-5TC ENCL 307 BRG (E-COAT)	1.000 EA
HA4054	SHORT T-DRAIN FITTING, .125" N.P.T.	1.000 EA
HW4606A04	JM CLIPPER/SEAL (LWE-1376-2125-AL45)	1.000 EA
HW4500A33	1/8 NPT STAINLESS,HOLO-KROME #13002,PRES	3.000 EA
10XN2520S28	1/4-20X 1 3/4 HEX HD SS X	4.000 EA
XY3118S12	5/16-18 HEX NUT, STAINLESS STEEL	4.000 EA
51XB1214A20	12-14X1.25 HXWSSLD SERTYB	1.000 EA
07FH4011LP2	WASHDOWN IEC FH	1.000 EA
10XN1032S08	10-32X1/2 HEX HEAD S STL	3.000 EA
36CB4518E	36 LIPPED CB LID E-COATING	1.000 EA
37GS1003	1/16 NEOPRENE GASKET-BLACK, CONDUIT BOX	1.000 EA

Parts List (continued)		
Part Number	Description	Quantity
59XN0832S07	8/32 X 7/16 HX WS HD SER X	4.000 EA
HW2502F21	#303 SS,SQ KEY 5/16 X 2.375	1.000 EA
HA7000A02	KEY RETAINER RING, 1 1/8 DIA, 1 3/8 DIA	1.000 EA
MJ5001A02	732 CL SEALANT 3 OZ DIXIE BEARING 289100	0.001 EA
85XU0407S04	4X1/4 U DRIVE PIN STAINLESS	2.000 EA
LB1115N	LABEL,LIFTING DEVICE (ON ROLLS)	1.000 EA
LB1164	LABEL,WARNING AND DRAIN	1.000 EA
MJ5001A23	P.D. GEORGE B-276 AIR DRY VARNISH	0.001 GA
LB1000	LABEL, DIRTY DUTY	1.000 EA
WD1000D21	TRM,T&B #B71M,RING,18-14,.25,NON-INSL	9.000 EA
MJ1000A02	GREASE, POLYREX EM EXXON (USe 4824-15A)	0.050 LB
MG1500Y02	PRIMER,347.29+347.29C ACTIVATOR WILKOPON	0.010 GA
MG1025L01	WILKOFASFD, 786.04, BLACK	0.010 GA
36FN3000C02	EXFN, PLASTIC, 5.25 OD, 1.175 ID	1.000 EA
HA3104S14	300UBOLT 12.125LG SS	4.000 EA
LC0005	CONN.DIA.,TY M,9-LD,DUAL VOLT,REVERSING	1.000 EA
NP3504E	SS DIRTY DUTY PLUS INV UL CSA-C US EEV	1.000 EA
37PA1039	PALLET PACK GRP, PRINT PK1026A06	1.000 EA
MN416A01	TAG-INSTAL-MAINT no wire (1200/bx) 11/14	1.000 EA

AC Induction Motor Performance Data

Record # 55760 - Typical performance - not guaranteed values

Winding: 37WGS864-R033	Type: 3728M	Enclosure: TEFC
-------------------------------	--------------------	------------------------

Nameplate Data				460 V, 60 Hz: High Voltage Connection	
Rated Output (HP)	10			Full Load Torque	15 LB-FT
Volts	230/460			Start Configuration	direct on line
Full Load Amps	23.6/11.8			Breakdown Torque	45.7 LB-FT
R.P.M.	3490			Pull-up Torque	21.9 LB-FT
Hz	60	Phase	3	Locked-rotor Torque	25.4 LB-FT
NEMA Design Code	B	KVA Code	G	Starting Current	76.1 A
Service Factor (S.F.)	1.15			No-load Current	4.12 A
NEMA Nom. Eff.	90.2	Power Factor	87	Line-line Res. @ 25°C	0.991 Ω
Rating - Duty	40C AMB-CONT			Temp. Rise @ Rated Load	79°C
S.F. Amps				Temp. Rise @ S.F. Load	98°C
				Locked-rotor Power Factor	33.1
				Rotor inertia	0.255 LB-FT ²

Load Characteristics 460 V, 60 Hz, 10 HP

% of Rated Load	25	50	75	100	125	150	S.F.
Power Factor	53	74	84	87	89	89	88
Efficiency	86.7	91	91.4	90.6	89.1	87.3	90
Speed	3575	3547	3516	3482	3445	3401	3464
Line amperes	4.94	6.85	9.1	11.8	14.7	18	13.5

Performance Graph at 460V, 60Hz, 10.0HP Typical performance - Not guaranteed values

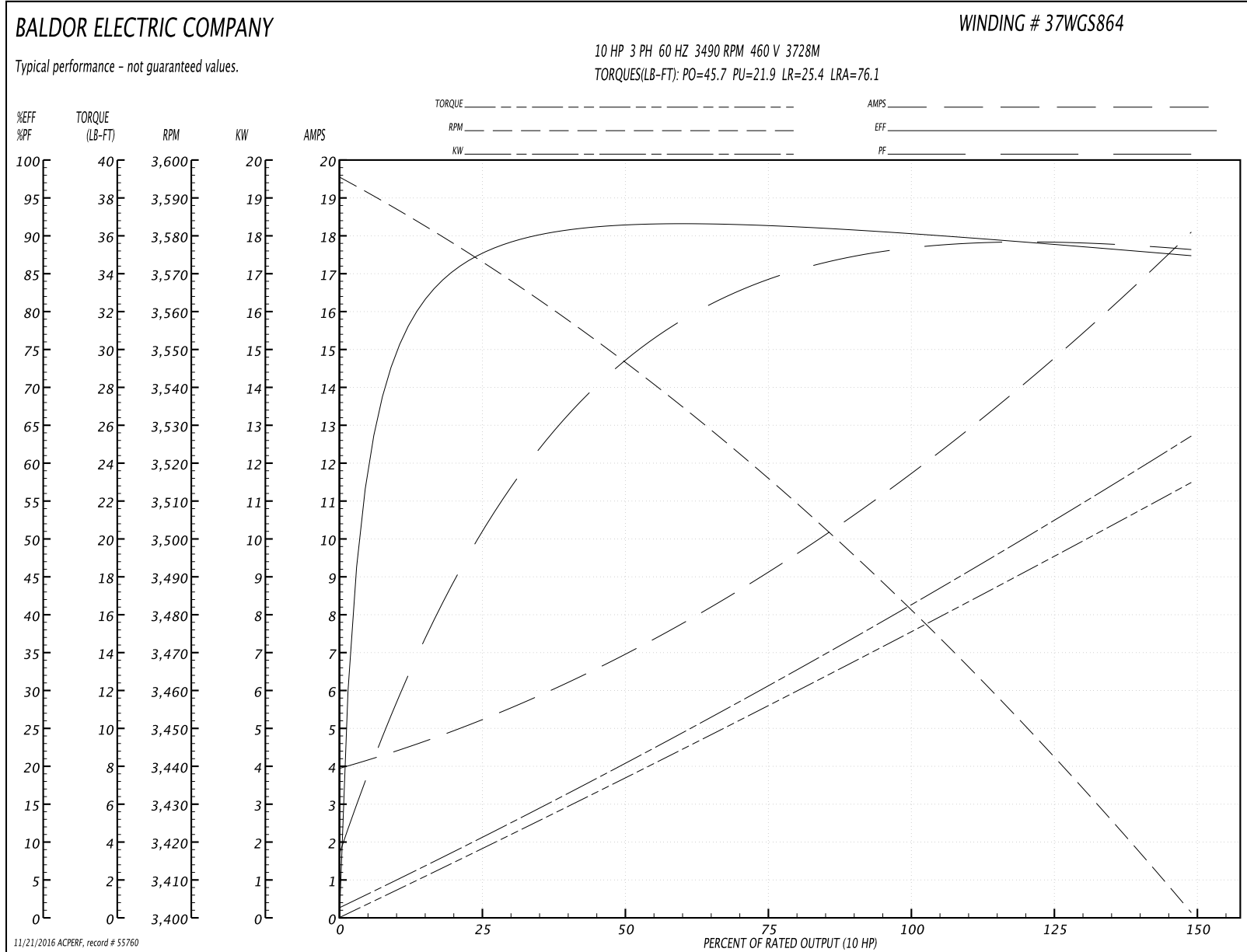

37LYN854

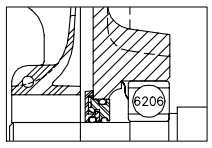
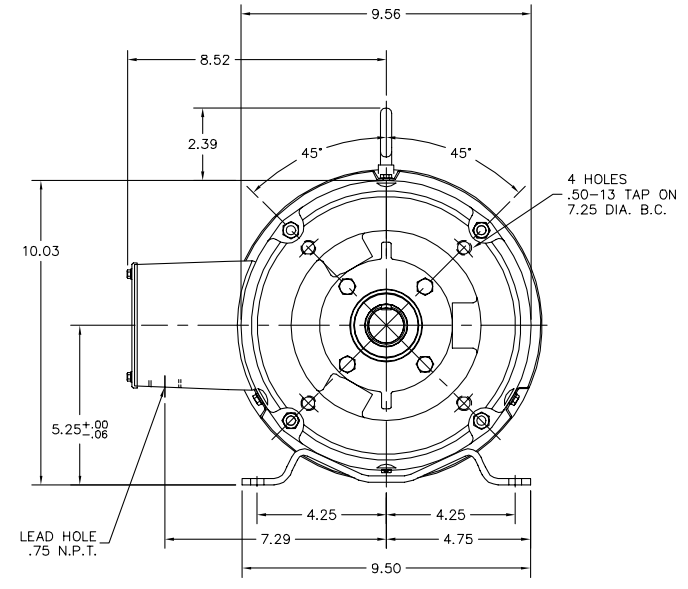
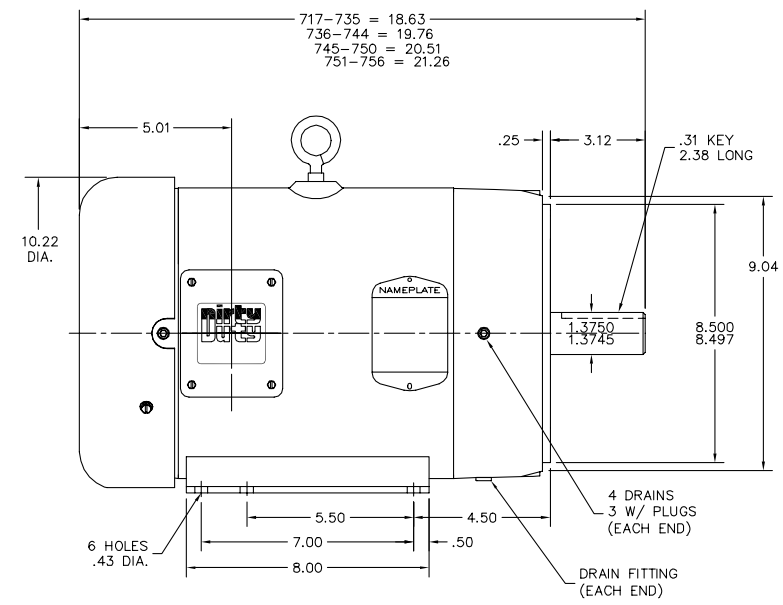

FRONT END DETAIL

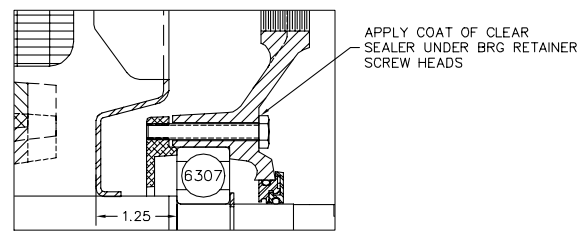

PULLEY END DETAIL

CUSTOMER IS RESPONSIBLE FOR DETERMINING THAT BALDOR'S PRODUCT WILL PERFORM SUITABLY IN THE INTENDED APPLICATION.

REV. DESC: NEW	VERSION: 00	TDR: 000000968673
REV. LTR: -	REvised: 06:38:31 04/14/2016	BY: ENCHALO
FILE: \AAA\00226\145		
MTL: -		

BALDOR
 STD HORZ 213-5TC TEFC 37M DDP
 SH 1 of 1

37LYN854

CD0005



LOW VOLTAGE
(2Y)



LINE

HIGH VOLTAGE
(1Y)



LINE

NOTES:

1. INTERCHANGE ANY TWO LINE LEADS TO REVERSE ROTATION.
2. OPTIONAL THERMOSTATS ARE PROVIDED WHEN SPECIFIED.
3. ACTUAL NUMBER OF INTERNAL PARALLEL CIRCUITS MAY BE A MULTIPLE OF THOSE SHOWN ABOVE.
4. LEAD COLORS ARE OPTIONAL. LEADS MUST ALWAYS BE NUMBERED AS SHOWN.

REV. DESC: REVISE TO SHOW OPTIONAL COLORS			
REV. LTR: E	BY: JLP	REVISED: 01/19/99 10:15	TDR: 0171435
9000D		FILE: AAA00005140	MDL: -
		MTL: -	

BALDOR ELECTRIC Co.

3PH, DV, 9 LEADS

CD0005