

BALDOR® • RELIANCE

Product Information Packet

CTM2276T

7.5HP, 1160RPM, 3PH, 60HZ, 254T, 0756M, TEAO, F

Part Detail							
Revision:	C	Status:	PRD/A	Change #:		Proprietary:	No
Type:	AC	Prod. Type:	0756M	Elec. Spec:	07WGX825	CD Diagram:	CD0005
Enclosure:	TEAO	Mfg Plant:		Mech. Spec:	07N393	Layout:	07LYN393
Frame:	254T	Mounting:	F1	Poles:	06	Created Date:	08-14-2015
Base:	RG	Rotation:	R	Insulation:	F	Eff. Date:	06-14-2016
Leads:	9#14					Replaced By:	
Literature:		Elec. Diagram:					

Nameplate NP1258E				
CAT.NO.	CTM2276T			
SPEC.	07N393X825H1			
HP	7.5			
VOLTS	208-230/460			
AMP	24-21.8/10.9			
RPM	1160			
FRAME	254T	HZ	60	
SER.F.	1.15	CODE	K	
NEMA-NOM-EFF	89.5	DES	A	
RATING	40C AMB-CONT		PH	3
CC		PF	72	
DE	6309	ODE	6206	
ENCL	TEAO	SN		
	1275 FPM 170 CFM			
			CL	F
			USABLE AT 208V	

Parts List		
Part Number	Description	Quantity
SA305823	SA 07N393X825H1	1.000 EA
RA293052	RA 07N393X825H1	1.000 EA
HW3201A01	1/2-13 EYEBOLT	1.000 EA
HA7205	"L" SHAPE LIFTING LUG FOR 37,39 & 40 FRA	2.000 EA
09CB1002A26G	KOBX W/1.00 NPT LD HL .25-20 TAP FOR LID	1.000 EA
RM1017	LEAD SEPERATOR GASKET MODEL 307 1/8" THK	1.000 EA
51XW2520A12	.25-20 X .75, TAPTITE II, HEX WSHR SLTD	2.000 EA
HA4044A00	PLUG,PIPE 1/8 NPT PLASTIC SQUARE HEAD	2.000 EA
11XW1032G06	10-32 X .38, TAPTITE II, HEX WSHR SLTD U	1.000 EA
HW3001B01	BRASS CUP WASHER, FOR #8 SCREW	1.000 EA
10XN2520S06	1/4 20X3/8 HX HD CAP S.S.	2.000 EA
WD1000B16	T&B CX70TN TERMINAL	2.000 EA
37EP1100C42G	35 EP FR TENV 206 BRG NO GRSR .125 NPT(E	1.000 EA
HA4054	SHORT T-DRAIN FITTING, .125" N.P.T.	1.000 EA
HA4044A00	PLUG,PIPE 1/8 NPT PLASTIC SQUARE HEAD	2.000 EA
HW5100A06	W2420-025 WVY WSHR (WB)	1.000 EA
07EP1116A59G	PUEP, 309 LOCK BRG, (3).125 NPT(GRAY)	1.000 EA
HW4600A27	SEAL 1.750 X 2.441 X 0.313 SINGLE LIP	1.000 EA
HA4054	SHORT T-DRAIN FITTING, .125" N.P.T.	1.000 EA
HA4044A00	PLUG,PIPE 1/8 NPT PLASTIC SQUARE HEAD	2.000 EA
10XN2520A32	1/4 X 2 HEX HEAD CAP SCR,GRADE 2	4.000 EA
XY3118A12	5/16-18 HEX NUT DIRECTIONAL SERRATION	4.000 EA
12CB1503A01G	CONDUIT BOX LID, MACH, WITH LIP,GREY	1.000 EA
12GS1002	GASKET, CONDUIT BOX LID, NEOP	1.000 EA

Parts List (continued)		
Part Number	Description	Quantity
10XN2520A12	O1/4-20X 3/4 HEX HEAD CAP	2.000 EA
HW1001A25	LOCKWASHER 1/4, ZINC PLT .493 OD, .255 I	2.000 EA
HW2501G25	KEY, 3/8 SQ X 2.875	1.000 EA
HA7000A03	KEY RETAINER RING 1.62 & 1.88 DIA. SH	1.000 EA
HW4600B67	V-RING SLINGER 1.770 X 2.170 X .28 VITON	1.000 EA
HW4600G53	DOME SLINGER, 5.438 OD X 1.620/1.562 ID	1.000 EA
MJ5001A27	32220KN GRAY SEALER *MIN BUY 4 QTS=1GAL	0.001 QT
85XU0407S04	4X1/4 U DRIVE PIN STAINLESS	2.000 EA
LB1115N	LABEL,LIFTING DEVICE (ON ROLLS)	1.000 EA
LB1182	WARNING LABEL FOR MOTORS WITH EYENUTS	1.000 EA
MJ1000A02	GREASE, POLYREX EM EXXON (USe 4824-15A)	0.050 LB
MG1025G29	WILKOFASST, 789.229, DARK CHARCOAL GRAY	0.036 GA
HA3104A25	THRUBOLT .31-18 X 14.75	4.000 EA
LC0005E01	CONN.DIA./WARNING LABEL (LC0005/LB1119N)	1.000 EA
NP1258E	SS CP UL CSA CC	1.000 EA
07PA1011	PKG GRP, 07 CAST IRON PK1181	1.000 EA
10XL3808A28	3/8 X 1 3/4" LAG SCREW	2.000 EA
MN416A01	TAG-INSTAL-MAINT no wire (1200/bx) 11/14	1.000 EA
LB1417	LABEL CARTON 6X4 PERFORATED BLANK ROLLS	1.000 EA

AC Induction Motor Performance Data

Record # 52119 - Typical performance - not guaranteed values

Winding: 07WGX825-R014	Type: 0756M	Enclosure: TEAO
-------------------------------	--------------------	------------------------

Nameplate Data				460 V, 60 Hz: High Voltage Connection	
Rated Output (HP)	7.5			Full Load Torque	33.78 LB-FT
Volts	208-230/460			Start Configuration	direct on line
Full Load Amps	24-21.8/10.9			Breakdown Torque	151 LB-FT
R.P.M.	1160			Pull-up Torque	76 LB-FT
Hz	60	Phase	3	Locked-rotor Torque	99.6 LB-FT
NEMA Design Code	A	KVA Code	K	Starting Current	82.4 A
Service Factor (S.F.)	1.15			No-load Current	5.5 A
NEMA Nom. Eff.	89.5	Power Factor	72	Line-line Res. @ 25°C	1.0788 Ω
Rating - Duty	40C AMB-CONT			Temp. Rise @ Rated Load	53°C
S.F. Amps				Temp. Rise @ S.F. Load	67°C
				Locked-rotor Power Factor	21.9

Load Characteristics 460 V, 60 Hz, 7.5 HP

% of Rated Load	25	50	75	100	125	150	S.F.
Power Factor	35	55	66	72	75	77	74
Efficiency	85.5	89.9	90.3	89.5	88	86.2	88.6
Speed	1190	1181	1171	1160.1	1147	1132	1152
Line amperes	5.82	7.07	8.75	10.8	13.3	15.9	12.3

Performance Graph at 460V, 60Hz, 7.5HP Typical performance - Not guaranteed values

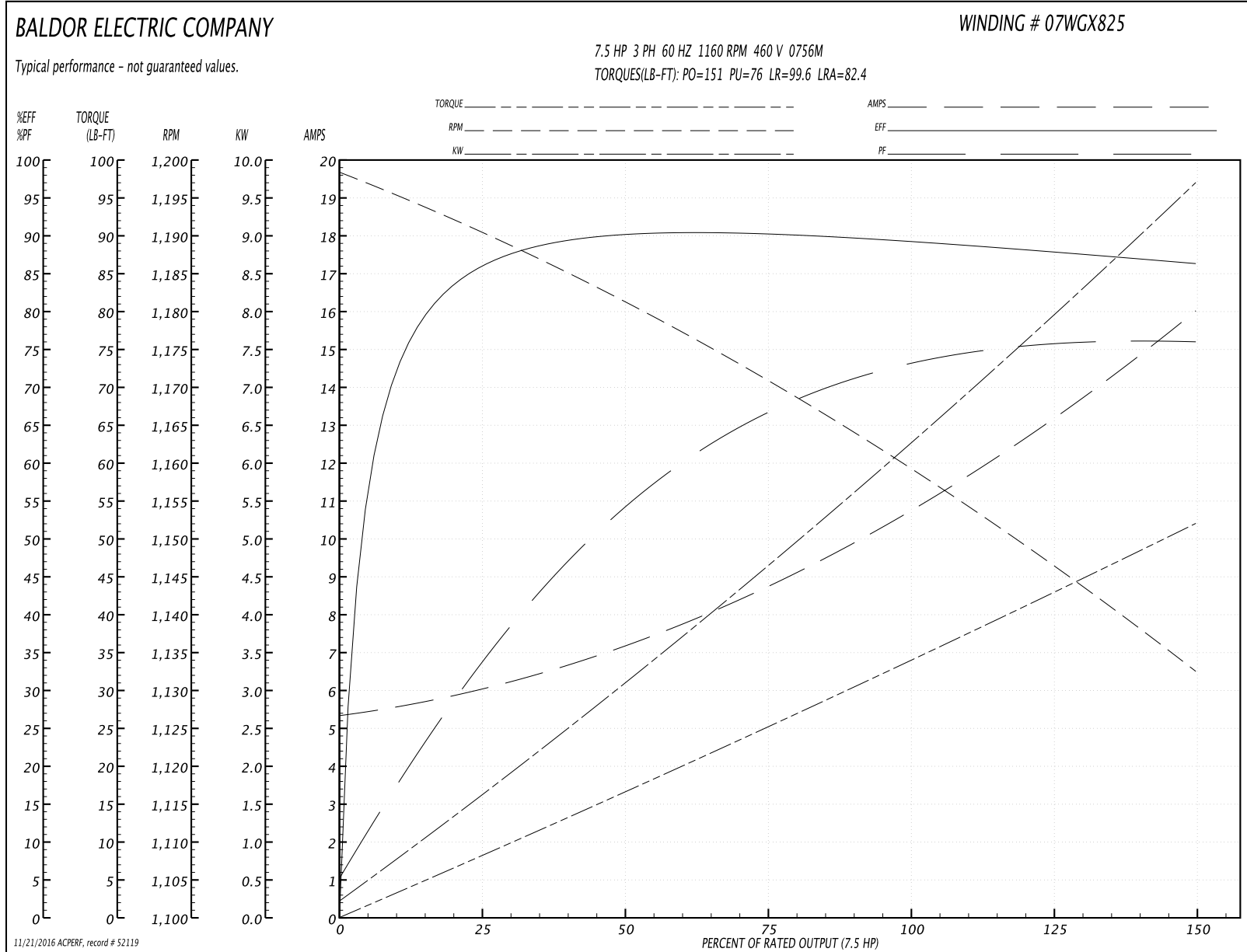

07LYN393

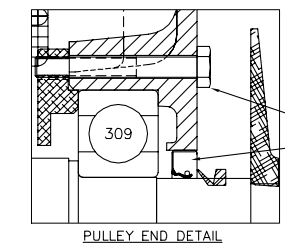
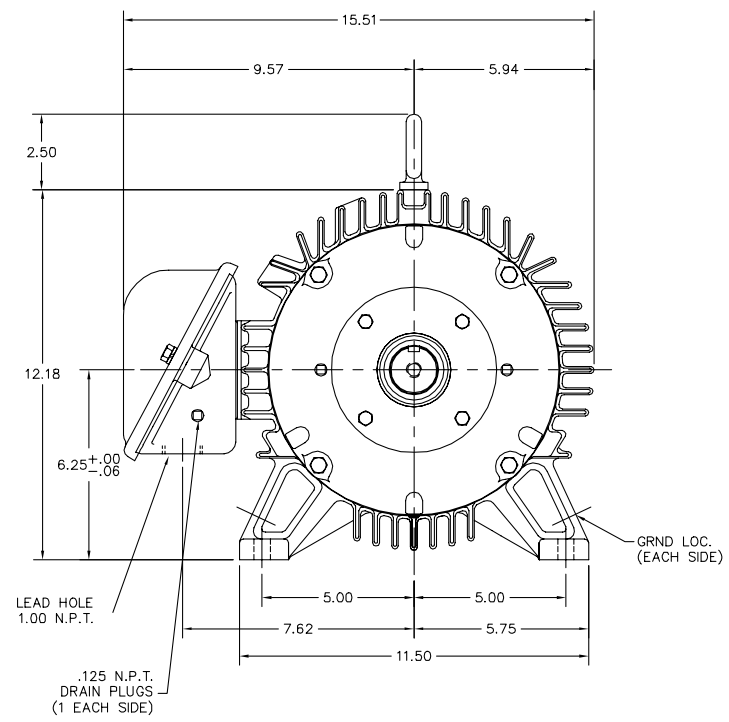
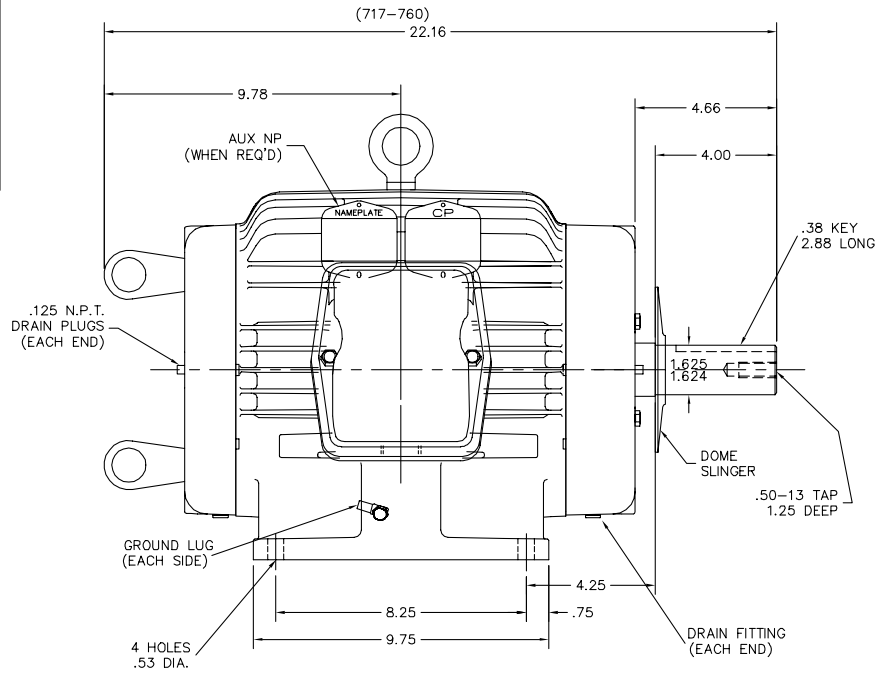

NOTE:
FOR VERTICAL SHAFT UP LIFTING,
REMOVE EYE BOLT FROM TOP OF MOTOR
AND SCREW INTO END OF SHAFT

APPLY SEALER TO
RET SCREW HEADS,
EP RABBETS, AND
SEAL O.D. BEFORE
PRESSING IN

CUSTOMER IS RESPONSIBLE FOR DETERMINING THAT BALDOR'S PRODUCT WILL PERFORM SUITABLY IN THE INTENDED APPLICATION.

REV. DESC: NEW	VERSION: 00	TDR: 000000936124
REV. LTR: -	REVISED: 11:05:59 08/19/2015	BY: ENSHARO
FILE: \AAA\00220\903		
MTL: -		

BALDOR

HOR 254T TEAO CP COOLING TOWER, LIFT, SLD BRGS, SEAL, DOME

SH 1 of 1

07LYN393

CD0005



LOW VOLTAGE
(2Y)



LINE

HIGH VOLTAGE
(1Y)

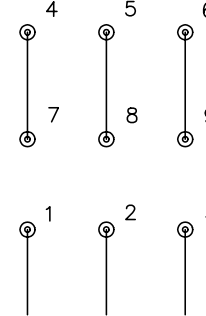

LINE

NOTES:

1. INTERCHANGE ANY TWO LINE LEADS TO REVERSE ROTATION.
2. OPTIONAL THERMOSTATS ARE PROVIDED WHEN SPECIFIED.
3. ACTUAL NUMBER OF INTERNAL PARALLEL CIRCUITS MAY BE A MULTIPLE OF THOSE SHOWN ABOVE.
4. LEAD COLORS ARE OPTIONAL. LEADS MUST ALWAYS BE NUMBERED AS SHOWN.

REV. DESC: REVISE TO SHOW OPTIONAL COLORS			
REV. LTR: E	BY: JLP	REVISED: 01/19/99 10:15	TDR: 0171435
90000		FILE: AAA00005140	MDL: -
		MTL: -	

BALDOR ELECTRIC Co.

3PH, DV, 9 LEADS

CD0005