

BALDOR® • *RELIANCE*

Product Information Packet

JMEWDM3616T

7.5HP,3450RPM,3PH,60HZ,184JM,3646M,TEFC

Part Detail							
Revision:	D	Status:	PRD/A	Change #:		Proprietary:	No
Type:	AC	Prod. Type:	3646M	Elec. Spec:	36WGS428	CD Diagram:	CD0005
Enclosure:	TEFC	Mfg Plant:		Mech. Spec:	36K605	Layout:	36LYK605
Frame:	184JM	Mounting:	F1	Poles:	02	Created Date:	12-04-2014
Base:	RG	Rotation:	R	Insulation:	F	Eff. Date:	09-01-2016
Leads:	9#16					Replaced By:	
Literature:		Elec. Diagram:					

Nameplate NP1669L										
CAT.NO.	JMEWDM3616T									
SPEC.	36K605S428G2									
HP	7.5									
VOLTS	230/460									
AMP	16.8/8.4									
RPM	3450									
FRAME	184JM					HZ	60		PH	3
SER.F.	1.15					CODE	L		DES	A
NEMA-NOM-EFF	89.5					PF	93		CLASS	F
RATING	40C AMB-CONT									
CC	010A							USABLE AT 208V	18.5	
DE	6207					ODE	6205			
ENCL	TEFC					SN				
BLANK										

Parts List		
Part Number	Description	Quantity
SA290730	SA 36K605S428G2	1.000 EA
RA276886	RA 36K605S428G2	1.000 EA
36CB3005A03W	36 CB .75 NPT @ 6 W/WHITE EPOXY	1.000 EA
35GS1022A03	GASKET BOX .125 THK WHITE NEOPRENE	1.000 EA
51XB1016A08	10-16X 1/2HXWSSLD SERTYB	2.000 EA
HA5027A01	HA4066A01 T-DRAIN X2 BAGGED	1.000 EA
11XW1032G06	10-32 X .38, TAPTITE II, HEX WSHR SLTD U	1.000 EA
36EP3104A03MW	FREP MACH (RAISED FH PADS) WHITE EPOXY	1.000 EA
HW4032A01	BLACK DRAIN PLUG FOR WASH DOWN MOTORS	3.000 EA
HW5100A05	WVY WSHR F/205 & 304 BRGS	1.000 EA
36EP1302A23MW	FACE MT EP FOR HOSE DOWN MTR W/WHITE EPO	1.000 EA
HW4600B51	SEAL 1.375 X 2.125 X 0.313 SINGLE LIP DB	1.000 EA
HW4032A01	BLACK DRAIN PLUG FOR WASH DOWN MOTORS	3.000 EA
10XN2520S26	1/4-20X 1 5/8 HEX HD SS	4.000 EA
51XB1214A16	12-14X1.00 HXWSSLD SERTYB	1.000 EA
36FH4010A08	IEC FH NO GREASER - W/PRIMER	1.000 EA
11XW1032S06	10-32 X .38, TAPTITE II, HEX WSHR SLTD U	3.000 EA
HW4600B32SP	V-RING SLINGER 1.000 X 1.540 X .24 VITON	1.000 EA
HW4600B33	V-RING SLINGER 1.375 X 1.890 X .35 VITON	1.000 EA
36CB4518	36 LIPPED CB LID PRIMED	1.000 EA
37GS3010	1/16"WHITE LID GASKET	1.000 EA
59XW0832S07	TAPTITE II,HEX WSHR UNSLTD SER,410 S.S.,	4.000 EA
HW2502D13	SS KEY, 3/16 SQ X 1.375	1.000 EA
HA7000A01	KEY RETAINER 7/8" DIA SHAFT	1.000 EA

Parts List (continued)		
Part Number	Description	Quantity
MJ5001A27	32220KN GRAY SEALER *MIN BUY 4 QTS=1GAL	0.001 QT
85XU0407S04	4X1/4 U DRIVE PIN STAINLESS	2.000 EA
LB1164	LABEL,WARNING AND DRAIN	1.000 EA
HW3200A01	3/8-16X3/4 I-BLT WELDED F/S	1.000 EA
MJ1000A02	GREASE, POLYREX EM EXXON (USe 4824-15A)	0.050 LB
35FN3002A04SP	EXFN, PLASTIC, 6.376 OD, .906 ID W/KEY	1.000 EA
MG1025Z02	ACTIVATOR WILKOFAS 060.02HF	0.010 GA
MG1025W01	WILKOFAS 781.01, SIGNAL WHITE #9003	0.022 GA
LB1115N	LABEL,LIFTING DEVICE (ON ROLLS)	1.000 EA
HA3101S28	THRUBOLT- 1/4-20 X 12.50 SS	4.000 EA
LC0005	CONN.DIA.,TY M,9-LD,DUAL VOLT,REVERSING	1.000 EA
MN416A01	TAG-INSTAL-MAINT no wire (1200/bx) 11/14	1.000 EA
NP1669L	SS WD SUPER-E UL CSA-EEV PREM REV MTG	1.000 EA
36PA1001	PKG GRP, PRINT PK1017A06	1.000 EA

AC Induction Motor Performance Data

Record # 52145 - Typical performance - not guaranteed values

Winding: 36WGS428-R020	Type: 3646M	Enclosure: TEFC
-------------------------------	--------------------	------------------------

Nameplate Data				460 V, 60 Hz: High Voltage Connection	
Rated Output (HP)	7.5			Full Load Torque	11.4 LB-FT
Volts	230/460			Start Configuration	direct on line
Full Load Amps	16.8/8.4			Breakdown Torque	57.9 LB-FT
R.P.M.	3450			Pull-up Torque	39.9 LB-FT
Hz	60	Phase	3	Locked-rotor Torque	48.2 LB-FT
NEMA Design Code	A	KVA Code	L	Starting Current	91 A
Service Factor (S.F.)	1.15			No-load Current	2.33 A
NEMA Nom. Eff.	89.5	Power Factor	93	Line-line Res. @ 25°C	1.43 Ω
Rating - Duty	40C AMB-CONT			Temp. Rise @ Rated Load	74°C
S.F. Amps				Temp. Rise @ S.F. Load	92°C
				Locked-rotor Power Factor	44.4
				Rotor inertia	0.205 LB-FT ²

Load Characteristics 460 V, 60 Hz, 7.5 HP

% of Rated Load	25	50	75	100	125	150	S.F.
Power Factor	64	85	90	93	94	94	94
Efficiency	86.9	90.6	91	90.1	88.8	86.5	89.3
Speed	3571	3539	3505	3468	3429	3385	3445
Line amperes	3.14	4.59	6.43	8.43	10.5	12.9	9.67

Performance Graph at 460V, 60Hz, 7.5HP Typical performance - Not guaranteed values

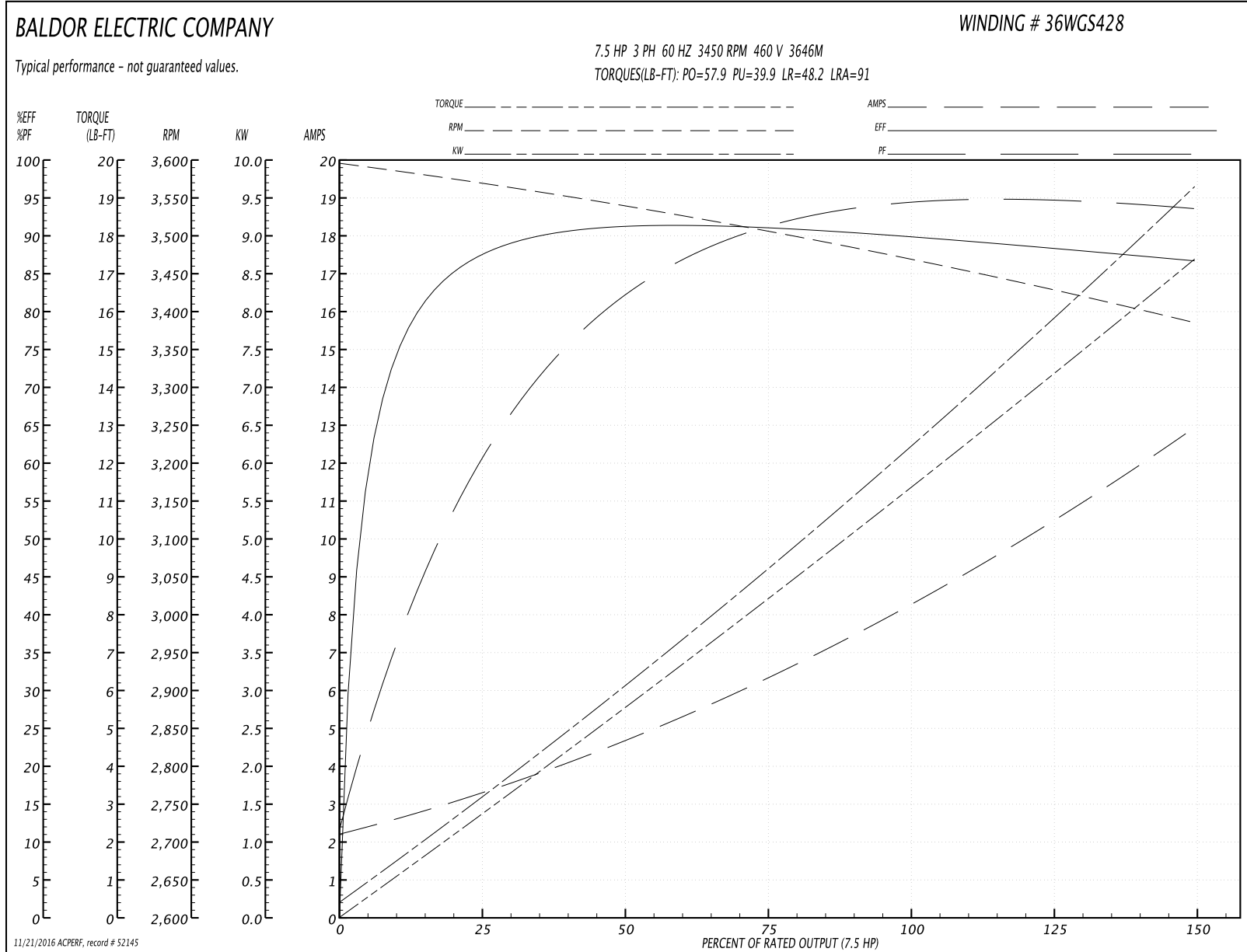

36LYK605

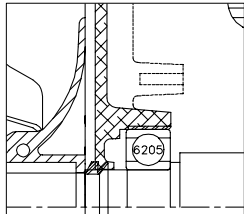
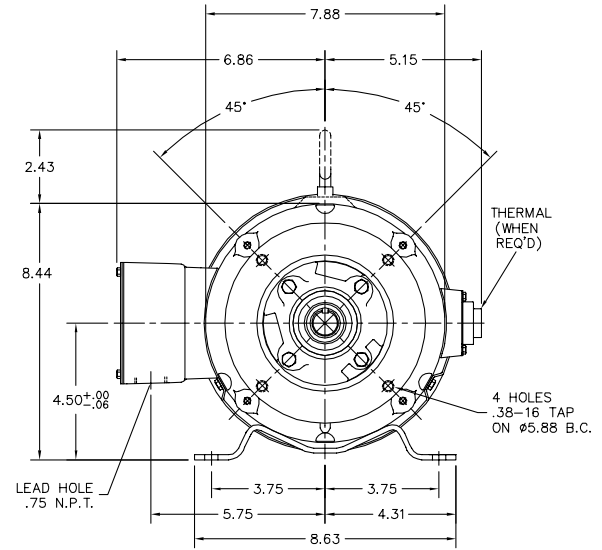
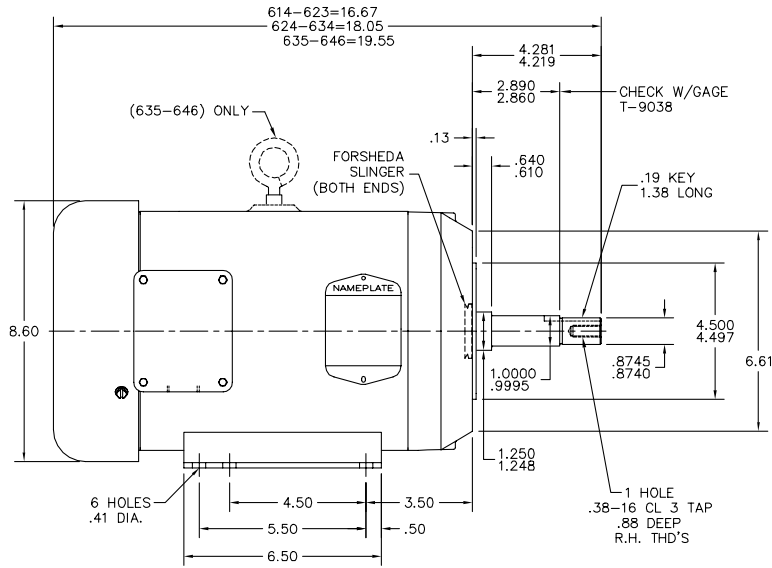

FRONT END SLINGER DETAIL

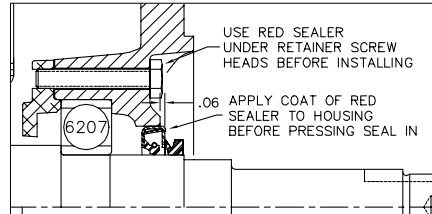

PULLEY END SEAL AND SLINGER DETAIL

CUSTOMER IS RESPONSIBLE FOR DETERMINING THAT BALDOR'S PRODUCT WILL PERFORM SUITABLY IN THE INTENDED APPLICATION.

REV. DESC: REPLACE HA1005AD3 WITH HW4600B32	VERSION: 01	TDR: 000000798198
REV. LTR: A	REVISED: 05:01:43 05/03/2013	BY: ENCARJ0
FILE: \AAA\00093\190		
MTL: -		

BALDOR
HOR 182-4JM TEFC 36M WD
SH 1 of 1

36LYK605

CD0005

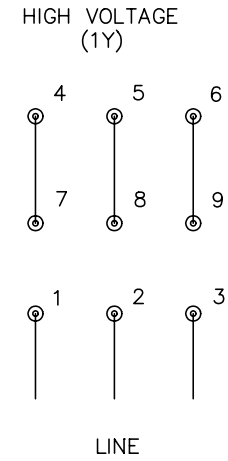
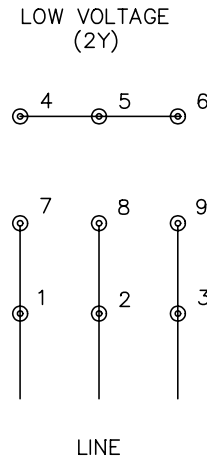

- NOTES:
1. INTERCHANGE ANY TWO LINE LEADS TO REVERSE ROTATION.
 2. OPTIONAL THERMOSTATS ARE PROVIDED WHEN SPECIFIED.
 3. ACTUAL NUMBER OF INTERNAL PARALLEL CIRCUITS MAY BE A MULTIPLE OF THOSE SHOWN ABOVE.
 4. LEAD COLORS ARE OPTIONAL. LEADS MUST ALWAYS BE NUMBERED AS SHOWN.

REV. DESC: REVISE TO SHOW OPTIONAL COLORS			
REV. LTR: E	BY: JLP	REVISED: 01/19/99 10:15	TDR: 0171435
900000		FILE: AAA00005140	MDL: -
		MTL: -	

BALDOR ELECTRIC Co.

3PH, DV, 9 LEADS

CD0005