

BARNES®

INSTALLATION and OPERATION MANUAL Submersible Sewage Ejector

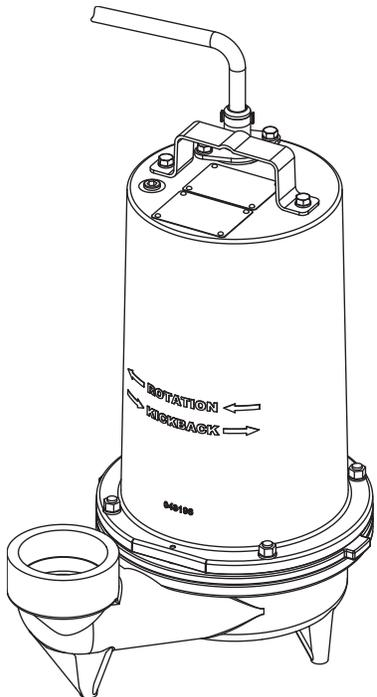

**Series: 3SE-L, 3HP
3450RPM, 60Hz**

**Series: 3SE-L, 3HP
1750RPM, 60Hz.**

(Single Seal)



IMPORTANT!

Read all instructions in this manual before operating pump.

As a result of Crane Pumps & Systems, Inc., constant product improvement program, product changes may occur. As such Crane Pumps & Systems reserves the right to change product without prior written notification.

CRANE[®]

A Crane Co. Company

PUMPS & SYSTEMS

420 Third Street
Piqua, Ohio 45356
Phone: (937) 778-8947
Fax: (937) 773-7157
www.cranepumps.com

83 West Drive, Brampton
Ontario, Canada L6T 2J6
Phone: (905) 457-6223
Fax: (905) 457-2650



Form No. 133410-Rev. B

TABLE OF CONTENTS

SAFETY FIRST	3
A. PUMP SPECIFICATIONS	4 - 5
B. GENERAL INFORMATION	6
C. INSTALLATION	6 - 7
ELECTRICAL DATA	7
D. START-UP OPERATION	7 - 8
E. PREVENTATIVE MAINTENANCE	8
F. SERVICE and REPAIR	8 - 11
G. REPLACEMENT PARTS.....	11
WIRING SCHEMATICS	12
TROUBLE SHOOTING	13
CROSS-SECTION 3SE-L 3450RPM (Fig. 9).....	14
EXPLODED VIEW 3SE-L 3450RPM (Fig. 10).....	15
PARTS LIST 3SE-L 3450RPM	16 - 17
CROSS-SECTION 3SE-L 1750RPM (Fig. 11)	18
EXPLODED VIEW 3SE-L 1750RPM (Fig. 12).....	19
PARTS LIST 3SE-L 1750RPM	20 - 21
WARRANTY	22
WARRANTY REGISTRATION	23
RETURNED GOODS POLICY.....	23
SPECIAL TOOLS AND EQUIPMENT	
INSULATION TESTER (MEGGER)	
DIELECTRIC TESTER	
SEAL TOOL KIT (see parts list)	
PRESSURE GAUGE KIT (see parts list)	

SAFETY FIRST!

Please Read This Before Installing Or Operating Pump.
This information is provided for **SAFETY and to PREVENT EQUIPMENT PROBLEMS**. To help recognize this information, observe the following symbols:



IMPORTANT! Warns about hazards that can result in personal injury or Indicates factors concerned with assembly, installation, operation, or maintenance which could result in damage to the machine or equipment if ignored.

CAUTION ! Warns about hazards that can or will cause minor personal injury or property damage if ignored. Used with symbols below.

WARNING ! Warns about hazards that can or will cause serious personal injury, death, or major property damage if ignored. Used with symbols below.



Hazardous fluids can cause fire or explosions, burns or death could result.



Extremely hot - Severe burns can occur on contact.



Biohazard can cause serious personal injury.



Hazardous fluids, hazardous pressure, eruptions or explosions could cause personal injury or property damage.



Rotating machinery Amputation or severe laceration can result.



Hazardous voltage can shock, burn or cause death.

Only qualified personnel should install, operate and repair the pump. Any wiring of pumps should be performed by a qualified electrician.



WARNING ! - To reduce risk of electrical shock, pumps and control panels must be properly grounded in accordance with the National Electric Code (NEC) or the Canadian Electrical Code (CEC) and all applicable state, province, local codes and ordinances.



WARNING! - To reduce risk of electrical shock, always disconnect the pump from the power source before handling or servicing. Lock out power and tag.



WARNING! Operation against a closed discharge valve will cause premature bearing and seal failure on any pump, and on end suction and self priming pump the heat build may cause the generation of steam with resulting dangerous pressures. It is recommended that a high case temperature switch or pressure relief valve be installed on the pump body.



CAUTION ! Never operate a pump with a plug-in type power cord without a ground fault circuit interrupter.



CAUTION! Pumps build up heat and pressure during operation-allow time for pumps to cool before handling or servicing.



WARNING! - **DO NOT** pump hazardous materials (flammable, caustic, etc.) unless the pump is specifically designed and designated to handle them.



Do not block or restrict discharge hose, as discharge hose may whip under pressure.



WARNING! - DO NOT wear loose clothing that may become entangled in the impeller or other moving parts.



WARNING! - Keep clear of suction and discharge openings. **DO NOT** insert fingers in pump with power connected.



Always wear eye protection when working on pumps.



Make sure lifting handles are securely fastened each time before lifting. **DO NOT** operate pump without safety devices in place. Always replace safety devices that have been removed during service or repair. Secure the pump in its operating position so it can not tip over, fall or slide.



DO NOT exceed manufacturers recommendation for maximum performance, as this could cause the motor to overheat.



DO NOT remove cord and strain relief. Do not connect conduit to pump.



WARNING! Cable should be protected at all times to avoid punctures, cut, bruises and abrasions - inspect frequently. Never handle connected power cords with wet hands.



WARNING! To reduce risk of electrical shock, all wiring and junction connections should be made per the NEC or CEC and applicable state or province and local codes. Requirements may vary depending on usage and location.



WARNING! Submersible Pumps are not approved for use in swimming pools, recreational water installations, decorative fountains or any installation where human contact with the pumped fluid is common.



WARNING! Products Returned Must Be Cleaned, Sanitized, Or Decontaminated As Necessary Prior To Shipment, To Insure That Employees Will Not Be Exposed To Health Hazards In Handling Said Material. All Applicable Laws And Regulations Shall Apply.



Bronze/brass and bronze/brass fitted pumps may contain lead levels higher than considered safe for potable water systems. Lead is known to cause cancer and birth defects or other reproductive harm. Various government agencies have determined that leaded copper alloys should not be used in potable water applications. For non-leaded copper alloy materials of construction, please contact factory.



IMPORTANT! - Crane Pumps & Systems, Inc. is not responsible for losses, injury, or death resulting from a failure to observe these safety precautions, misuse or abuse of pumps or equipment.

**SECTION: A - PUMP SPECIFICATIONS:
3450RPM**

DISCHARGE 3" NPT, Vertical
LIQUID TEMPERATURE . 104°F (40°C) Continuous
MOTOR HOUSING Cast Iron ASTM A-48, Class 30
VOLUTE Cast Iron ASTM A-48, Class 30
SEAL PLATE Cast Iron, Class 30
IMPELLER:
Design 2 Vane, Semi-open with Pump out vanes on Back side. Dynamically balanced, ISO G6.3
Material Cast Iron, Class 30
SHAFT 416 Stainless Steel
SQUARE RINGS Buna-N
HARDWARE 300 Series Stainless Steel
PAINT Air dry enamel, top coat
SEAL *Design* Single Mechanical in oil filled reservoir
Material Rotating Faces - Carbon
 Stationary Faces - Ceramic
 Elastomer - Buna-N
 Hardware - 300 series stainless steel
CORD ENTRY 30 Ft. (9.1m) Cord. Quick connect custom molded for sealing and strain relief.
SPEED 3450RPM, 60Hz (nominal)

UPPER BEARING: Single Row, Ball, Oil Lubricated
Load Radial
LOWER BEARING:
Design Single Row, Ball, Oil Lubricated
Load Radial & Thrust
MOTOR: *Design* NEMA B, Three Phase Torque Curve, Oil Filled, Squirrel Cage Induction
Insulation Class B
THREE PHASE 200-230/460, 60Hz is Tri voltage motor. 575V. Requires overload protection to be included in control panel
OPTIONAL EQUIPMENT.. Seal Material, Impeller Trims, Additional Cord.

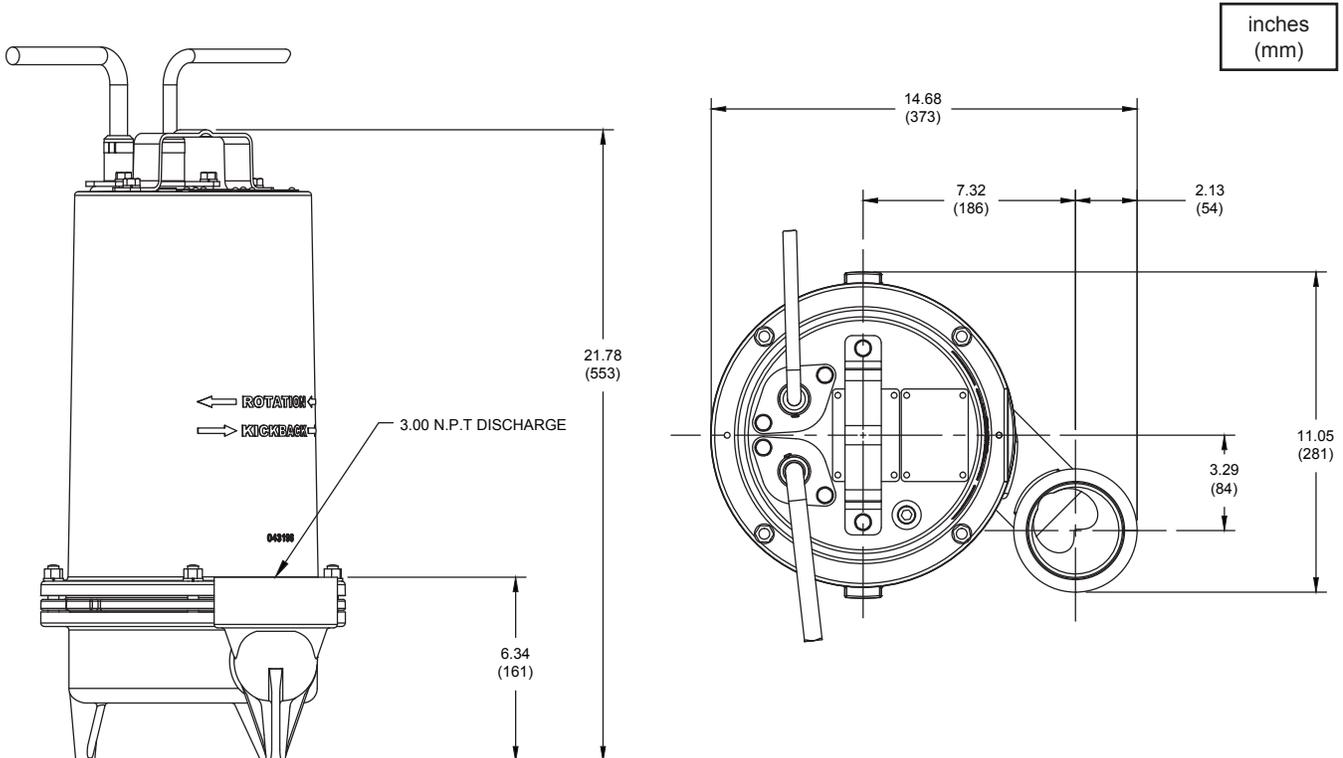

IMPORTANT !

- 1.) PUMP MAY BE OPERATED "DRY" FOR EXTENDED PERIODS WITHOUT DAMAGE TO MOTOR AND/OR SEALS.
- 2.) THIS PUMP IS APPROPRIATE FOR THOSE APPLICATIONS SPECIFIED AS CLASS I DIVISION 2 HAZARDOUS LOCATIONS.
- 3.) THIS PUMP IS NOT APPROPRIATE FOR THOSE APPLICATIONS SPECIFIED AS CLASS I DIVISION 1 HAZARDOUS LOCATIONS.
- 4.) INSTALLATIONS SUCH AS DECORATIVE FOUNTAINS OR WATER FEATURES PROVIDED FOR VISUAL ENJOYMENT MUST BE INSTALLED IN ACCORDANCE WITH THE NATIONAL ELECTRIC CODE ANSI/NFPA 70 AND/OR THE AUTHORITY HAVING JURISDICTION. THIS PUMP IS NOT INTENDED FOR USE IN SWIMMING POOLS, RECREATIONAL WATER PARKS, OR INSTALLATIONS IN WHICH HUMAN CONTACT WITH PUMPED MEDIA IS A COMMON OCCURRENCE.

**SECTION: A - PUMP SPECIFICATIONS:
1750RPM**

DISCHARGE 3" NPT, Vertical
LIQUID TEMPERATURE . 104°F (40°C) Continuous
MOTOR HOUSING Cast Iron ASTM A-48, Class 30
VOLUTE Cast Iron ASTM, Class 30
SEAL PLATE Cast Iron ASTM, Class 30
IMPELLER:
Design 2 Vane, Semi-open with Pump out vanes on Back side. Dynamically balanced, ISO G6.3
Material Cast Iron, Class 30
SHAFT 416 Stainless Steel
SQUARE RINGS Buna-N
HARDWARE 300 Series Stainless Steel
PAINT Air dry enamel, top coat
SEAL *Design* Single Mechanical in oil filled reservoir
Material Rotating Faces - Carbon
 Stationary Faces - Ceramic
 Elastomer - Buna-N
 Hardware - 300 series stainless steel
CORD ENTRY 30 Ft. (9.1m) Cord. Quick connect custom molded for sealing and strain relief.

SPEED 1750RPM, 60Hz (nominal)
UPPER BEARING:
Design Single Row, Ball, Oil Lubricated
Load Radial
LOWER BEARING:
Design Single Row, Ball, Oil Lubricated
Load Radial & Thrust
MOTOR: *Design* NEMA L, Single phase, NEMA B, Three Phase Torque Curve, Oil Filled, Squirrel Cage Induction
Insulation Class B
SINGLE PHASE Permanent Split Capacitor (PSC) Includes overload protection in motor
THREE PHASE 200-230/460, 60Hz is Tri voltage motor. Requires overload protection to be included in control panel
OPTIONAL EQUIPMENT.. Seal Material, Impeller Trims, Additional Cord.

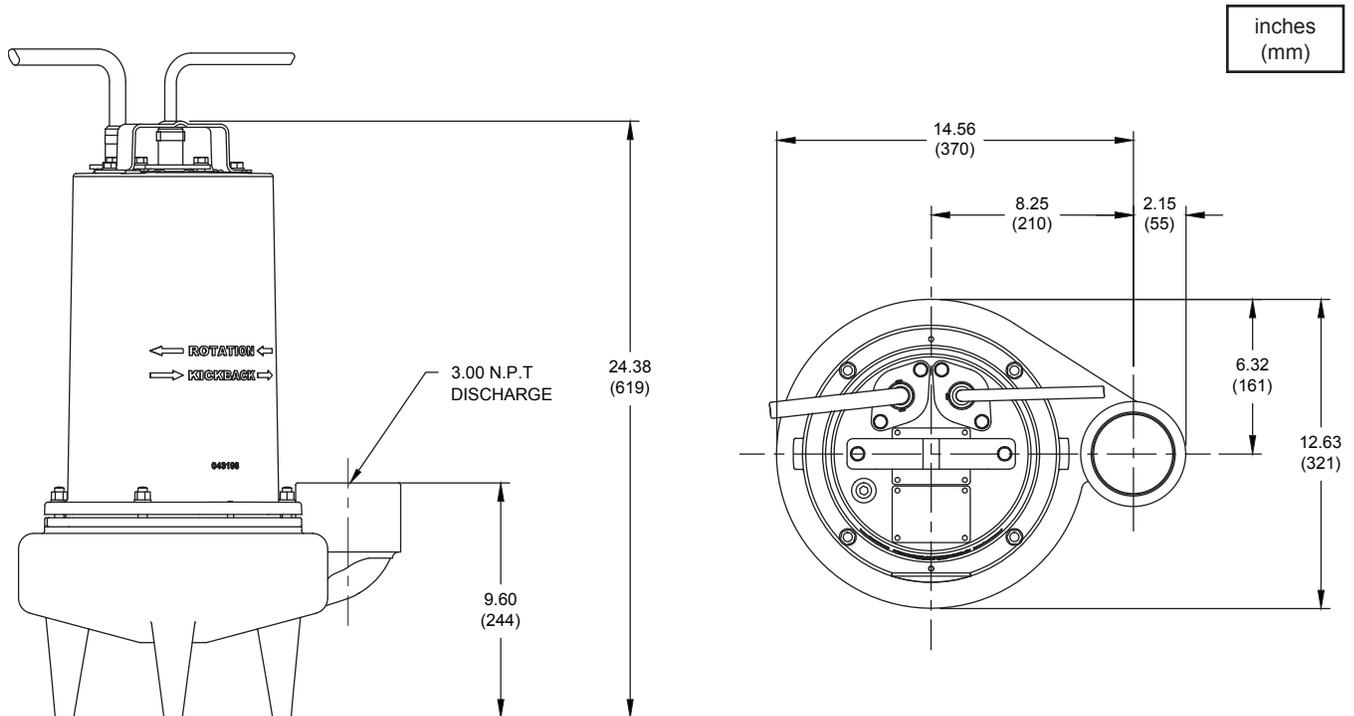

IMPORTANT !

- 1.) PUMP MAY BE OPERATED "DRY" FOR EXTENDED PERIODS WITHOUT DAMAGE TO MOTOR AND/OR SEALS.
- 2.) THIS PUMP IS APPROPRIATE FOR THOSE APPLICATIONS SPECIFIED AS CLASS I DIVISION 2 HAZARDOUS LOCATIONS.
- 3.) THIS PUMP IS NOT APPROPRIATE FOR THOSE APPLICATIONS SPECIFIED AS CLASS I DIVISION 1 HAZARDOUS LOCATIONS.
- 4.) INSTALLATIONS SUCH AS DECORATIVE FOUNTAINS OR WATER FEATURES PROVIDED FOR VISUAL ENJOYMENT MUST BE INSTALLED IN ACCORDANCE WITH THE NATIONAL ELECTRIC CODE ANSI/NFPA 70 AND/OR THE AUTHORITY HAVING JURISDICTION. THIS PUMP IS NOT INTENDED FOR USE IN SWIMMING POOLS, RECREATIONAL WATER PARKS, OR INSTALLATIONS IN WHICH HUMAN CONTACT WITH PUMPED MEDIA IS A COMMON OCCURRENCE.

SECTION B: GENERAL INFORMATION

B-1) To the Purchaser:

Congratulations! You are the owner of one of the finest pumps on the market today. CP&S pumps are products engineered and manufactured of high quality components. Over one hundred years of pump building experience along with a continuing quality assurance program combine to produce a pump which will stand up to the toughest applications. This manual will provide helpful information concerning installation, maintenance, and proper service guidelines.

B-2) Receiving:

Upon receiving the pump, it should be inspected for damage or shortages. If damage has occurred, file a claim immediately with the company that delivered the pump. If the manual is removed from the packaging, do not lose or misplace.

B-3) Storage:

Short Term- CP&S Pumps are manufactured for efficient performance following short inoperative periods in storage. For best results, pumps can be retained in storage, as factory assembled, in a dry atmosphere with constant temperatures for up to six (6) months.

Long Term- Any length of time exceeding six (6) months, but not more than twenty-four (24) months. The unit should be stored in a temperature controlled area, a roofed over walled enclosure that provides protection from the elements (rain, snow, wind-blown dust, etc.), and whose temperature can be maintained between +40°F and +120°F. (4.4 - 49°C).

Pump should be stored in its original shipping container. On initial start up, rotate impeller by hand to assure seal and impeller rotate freely. If it is required that the pump be installed and tested before the long term storage begins, such installation will be allowed provided:

- 1.) The pump is not installed under water for more than one (1) month.
- 2.) Immediately upon satisfactory completion of the test, the pump is removed, thoroughly dried, repacked in the original shipping container, and placed in a temperature controlled storage area.

B-4) Service Centers:

For the location of the nearest CP&S Service Center, check your CP&S representative or Crane Pumps & Systems, Inc., Service Department in Piqua, Ohio, telephone (937) 778-8947 or Crane Pumps & Systems Canada, in Brampton, Ontario, (905) 457-6223.

SECTION C: INSTALLATION

C-1) Location:

These pumping units are self-contained and are recommended for use in a sump, lift station or basin. The sump, lift station or basin shall be vented in accordance with local plumbing codes. This pump is designed to pump sewage, effluent, or other nonexplosive or noncorrosive wastewater. and shall **NOT** be installed in locations classified as Class I Division 1 hazardous in accordance with the National Electrical Code (NEC), ANSI/NFPA 70 or The Canadian Electrical Code. Never install the pump in a trench,

ditch or hole with a dirt bottom; the legs will sink into the dirt and the suction will become plugged.

C-1.1) Submergence:

It is recommended that the pump be operated in the submerged condition and the sump liquid level should never be less than dimension "A" in Figure 1.

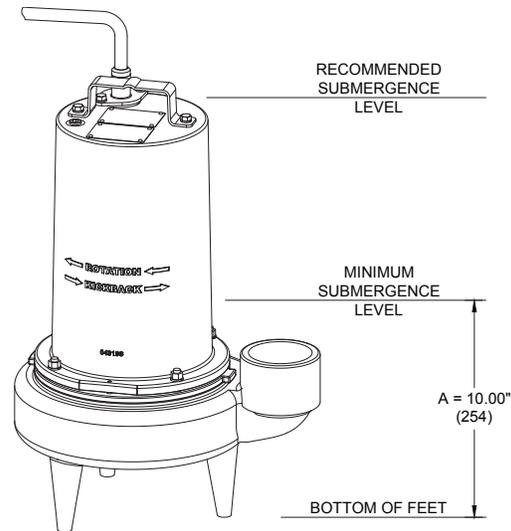

FIGURE 1

C-2) Discharge:

Discharge piping should be as short as possible. Both a check valve and a shut-off valve are recommended for each pump being used. The check valve is used to prevent backflow into the sump. Excessive backflow can cause flooding and/or damage to the pump. The shut-off valve is used to stop system flow during pump or check valve servicing.

CP&S Pumps supplies a breakaway fitting discharge system designed to allow the submersible wastewater pump to be installed or removed without requiring personnel to enter the wet well.

Place the Break Away Fitting (BAF) in position. Temporarily secure the guide rails in the upper mounting brackets and locate the base on the bottom of the wet well. Level the base with grout and/or shims. Install the intermediate support brackets, if required. Make sure the rails are in a true vertical position so the pump will clear the access opening and will slide freely down the rails into place on the discharge stationary fitting. Once the rails are in proper alignment, bolt the base into the floor of the station and connect the discharge pipe to the elbow.

Connect the movable portion and other supplied fittings of the BAF onto the pump and lower into wet well. See the Break Away Fitting manual for more information.

C-3) Liquid Level Controls:

The level controls are to be supported by a mounting bracket that is attached to the sump wall, cover or junction box. Cord grips are used to hold the cords in place on the mounting bracket. The control level can be changed by loosening the grip and adjusting the cord length as per the plans and specifications. Be certain that the level controls cannot hang up or foul in it's swing and that the pump is completely submerged when the level control is in the "Off" mode.

C-4) Electrical Connections:

C-4.1) Power Cord:

The cord assembly mounted to the pump must not be modified in any way except for shortening to a specific application. Any splice between the pump and the control panel must be made in accordance with all applicable electric codes. It is recommended that a junction box, if used, be mounted outside the sump or be of at least NEMA 4 (EEMAC-4) construction if located within the wet well. Do not use the power cable to lift pump. **NOTE: THE WHITE WIRE IS NOT A NEUTRAL OR GROUND LEAD, BUT A POWER CARRYING CONDUCTOR. THE GREEN LEAD IS FOR CONNECTION TO GROUND.**

C-4.2) Sensor Cord:

The cord assembly mounted to the pump must not be modified in any way except for shortening to a specific application. Any splice between the pump and the control panel must be made in accordance with all applicable electric codes. It is recommended that a junction box, if used, be mounted outside the sump or be of at least NEMA 4 (EEMAC-4) construction if located within the wet well. Do not use the control cable to lift pump. **NOTE: THE WHITE WIRE IS NOT A NEUTRAL OR GROUND LEAD, BUT A POWER CARRYING CONDUCTOR. THE GREEN LEAD IS FOR CONNECTION TO GROUND.**

C-4.3) Overload Protection :

C-4.3-1) Single and Three Phase - The normally closed (N/C) thermal sensor is embedded in the motor windings and will detect excessive heat in the event and overload condition occurs. The thermal sensor will trip when the windings become to hot and will automatically reset itself when the pump motor cools to a safe temperature. It is recommended that the thermal sensor be connected in series to an alarm device to alert the operator of an overload condition, and/or the motor starter coil to stop the pump. In the event of an overload, the source of this condition should be determined and rectified immediately. **DO NOT LET THE PUMP CYCLE OR RUN IF AN OVERLOAD CONDITION OCCURS!**

If current through the temperature sensor exceeds the values listed, an intermediate control circuit relay must be used to reduce the current or the sensor will not work properly.

TEMPERATURE SENSOR ELECTRICAL RATINGS		
Volts	Continuous Amperes	Inrush Amperes
220-240	1.50	15.0
440-480	0.75	7.5
575-600	0.60	6.0

C-4.4) Wire Size:

Consult a qualified electrician for proper wire size if additional power cable length is required. See table for electrical information.

SECTION: D START-UP OPERATION

D-1) Check Voltage and Phase:

Before operating pump, compare the voltage and phase information stamped on the pump identification plate to the available power.

D-2) Check Pump Rotation:

Before putting pump into service for the first time, the motor rotation must be checked. Improper motor rotation can result in poor pump performance and can damage the motor and/or pump. To check the rotation, suspend the pump freely, momentarily apply power and observe the "kickback". "Kickback" should always be in a counter-clockwise direction as viewed from the top of the pump motor housing.

D-2.1) Incorrect Rotation for Three-Phase Pumps:

In the event that the rotation is incorrect for a three-phase installation, interchange any two power cable leads at the control box. **DO NOT** change leads in the cable housing in the motor. Recheck the "kickback" rotation again by momentarily applying power.

D-2.2) Incorrect Rotation for Single-Phase Pumps:

In the unlikely event that the rotation is incorrect for a single phase pump, contact a CP&S Service Center.

D-3) Pump Reference Information:

D-3.1) Identification Plate:

Record the numbers from the pump identification plate.

D-3.2) Insulation Test:

Before the pump is put into service, an insulation (megger) test should be performed on the motor. The resistance values (ohms) as well as the voltage (volts) and current (amps) should be recorded.

MODEL NO	HP	VOLT/PH	Hz	RPM (Nom)	NEMA START CODE	FULL LOAD AMPS	LOCKED ROTOR AMPS	CORD SIZE	CORD TYPE	CORD O.D inch (mm)	WINDING RESISTANCE MAIN - START
3SE3032L	3.0	230/3	60	3450	B	16.4	40.0	12/4	SOOW/SOW	.68 (17.4)	2.30
3SE3042L	3.0	460/3	60	3450	B	8.2	20.0	14/4	SOOW/SOW	.57 (14.5)	9.10
3SE3052L	3.0	575/3	60	3450	B	6.5	16.0	14/4	SOOW/SOW	.57 (14.5)	14.10
3SE3024L	3.0	230/1	60	1750	A	28.0	59.0	10/3	SOOW/SOW	.66 (16.8)	0.84 - 4.0
3SE3034L	3.0	230/3	60	1750	D	19.0	56.0	12/4	SOOW/SOW	.68 (17.4)	1.40
3SE3044L	3.0	460/3	60	1750	D	9.0	28.0	14/4	SOOW/SOW	.57 (14.5)	6.30
3SE3054L	3.0	575/3	60	1750	E	8.3	23.0	14/4	SOOW/SOW	.57 (14.5)	9.90

Winding Resistance ± 5%. Pump rated for operation at ± 10% voltage at motor.

D-3.3) Pump-Down Test:

After the pump has been properly wired and lowered into the basin, sump or lift station, it is advisable to check the system by filling with liquid and allowing the pump to operate through its pumping cycle. The time needed to empty the system, or pump-down time along with the volume of water, should be recorded.

SECTION E: PREVENTATIVE MAINTENANCE

As the motor is oil filled, no lubrication or other maintenance is required, and generally CP&S pumps will give very reliable service and can be expected to operate for years on normal sewage pumping without failing. However as with any mechanical piece of equipment a preventive maintenance program is recommended and suggested to include the following checks:

- 1) Inspect motor chamber for oil level and contamination and repair as required per section F-1.
- 2) Inspect impeller and body for excessive build-up or clogging and repair as required per section F-2.
- 3) Inspect motor, bearings and shaft seal for wear or leakage, replace as required per section F-3.
- 4) Inspect seal for wear on leakage and repair as required per section F-3.

SECTION F: SERVICE AND REPAIR

NOTE: All item numbers in () refer to Figures 11 & 12, 3450RPM and Figures 13 & 14 , 1750RPM.

F-1) Lubrication:

Anytime the pump is removed from operation the cooling oil in the motor housing (2) must be checked visually for oil level and contamination.

F-1.1) Checking Oil:

Motor Housing - To check oil, set unit upright. Remove pipe plug (5) from motor housing (2). With a flashlight, visually inspect the oil in the motor housing (2) to make sure it is clean and clear, light amber in color and free from suspended particles. Milky white oil indicates the presence of water. Oil level should be just above the motor when pump is in a vertical position.

F-1.2) Testing Oil:

1. Place pump on it's side, remove pipe plug (5) from motor housing (2) and drain oil into a clean, dry container.
2. Check oil for contamination using an oil tester with a range to 30 Kilovolts breakdown.
3. If oil is found to be clean and uncontaminated (measure above 15 KV. breakdown), refill the motor housing as per section F-1.3.
4. If oil is found to be dirty or contaminated (or measures below 15 KV. breakdown), the the pump must be carefully inspected for leaks at the shaft seal (46), cord assemblies (10) and (11, if used), square ring (42) and pipe plugs (5) before refilling with oil.. To locate the leak, perform a pressure test as per section F-1.4. After leak is repaired, refill with new oil as per section F-1.3.

F-1.3) Replacing Oil:

Motor Housing - Set unit upright and refill with new cooling oil as per Table 1 (see parts list for amount). Fill to just above motor as an air space must remain in the top of the motor housing (2) to compensate for oil expansion (see Figures 2, 11, or 13). Apply thread locking compound to each pipe plug (5) then assemble to motor housing (2).

SUPPLIER	GRADE
Sohio / Standard	SE 40, Energol HL22 or HL32
Shell	Turbo Oil 32
Texaco	Rando HD32, 522
Sun Petroleum	Supar 110, Sunvis 816WR, 911 or 916
Mobile	D.T.E. Oil Light or Rubrex 200
G&G	Circu Oil 22
Allegheny Petroleum	Altrapar 22
Woco	Premium 100



Important! - Do not overfill oil. Overfilling of motor housing with oil can create excessive and dangerous hydraulic pressure which can destroy the pump and create a hazard. Overfilling oil voids warranty.

F-1.4) Pressure Test:

Pumps that have had oil drained from the Motor Housing

- Apply pipe sealant to pressure gauge assembly and tighten into pipe plug hole (see Figure 2). Pressurize motor housing to 10 P.S.I. Use a soap solution around the sealed areas and inspect joints for "air bubbles". If, after five minutes, the pressure is still holding constant, and no "bubbles" are observed, slowly bleed the pressure and remove the gauge assembly. Replace the pipe plug using a sealant. If the pressure does not hold, then the leak must be located and repaired.

Pumps that have had oil drained from the Motor Housing

- The pressure test may not be done with the oil at its normal level. Remove pipe plug (5) from motor housing (2). Apply pipe sealant to pressure gauge assembly and tighten into hole (see Figure 2). Pressurize motor housing to 10 P.S.I. Use soap solution around the sealed areas above the oil level and inspect joints for "air bubbles". For sealed areas below the oil level, leaks will seep oil.

If, after five minutes, the pressure is still holding constant, and no "bubbles" / oil seepage is observed, slowly bleed the pressure and remove the gauge assembly. If the pressure does not hold, then the leak must be located and repaired.

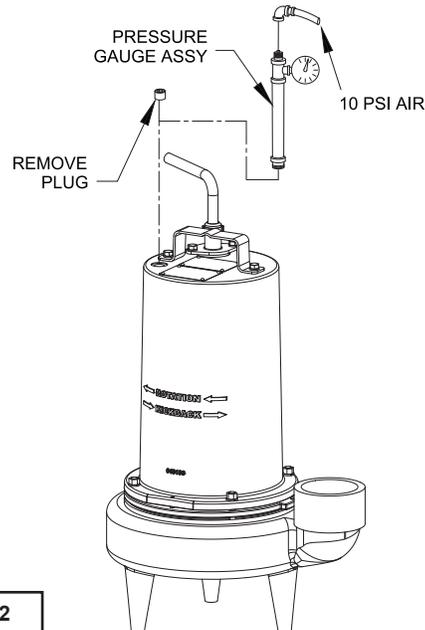

FIGURE 2

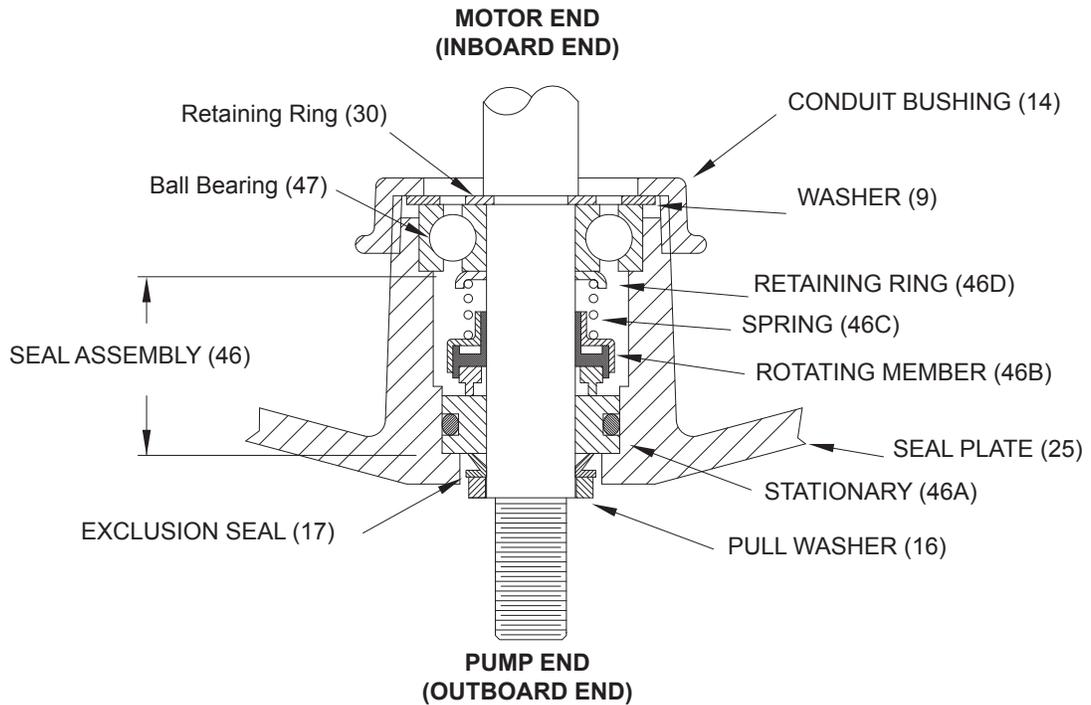

FIGURE 3



Caution! - Pressure builds up extremely fast, increase pressure by "tapping" air nozzle. Too much pressure will damage seal. Do Not exceed 10 P.S.I. in motor housing.

F-2) Impeller and Volute Service:

F-2.1) Disassembly and Inspection:

To clean out volute (26), or replace impeller (28), disconnect power, remove hex nuts (20) and lock washers (19), vertically lift motor and seal assembly from volute (26). Clean out volute if necessary. Clean and examine impeller (28) for pitting or wear, replace if required. Inspect square ring (42) and replace if cut or damaged. If impeller (28) requires replacing, remove jam nut (34) and washer (35). The impeller is keyed onto the shaft with a square key (33) and to remove, pull impeller straight off the shaft using a wheel puller, if required. Before reinstalling, check the motor shaft and impeller bore for damage. Once impeller (28) is removed, remove pull washer (16) and exclusion seal (17) if damaged or cut. (See Figure 9 and 10)

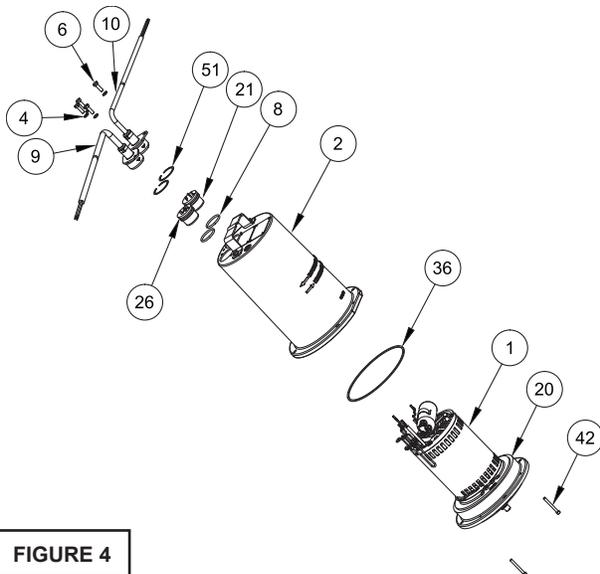

FIGURE 4

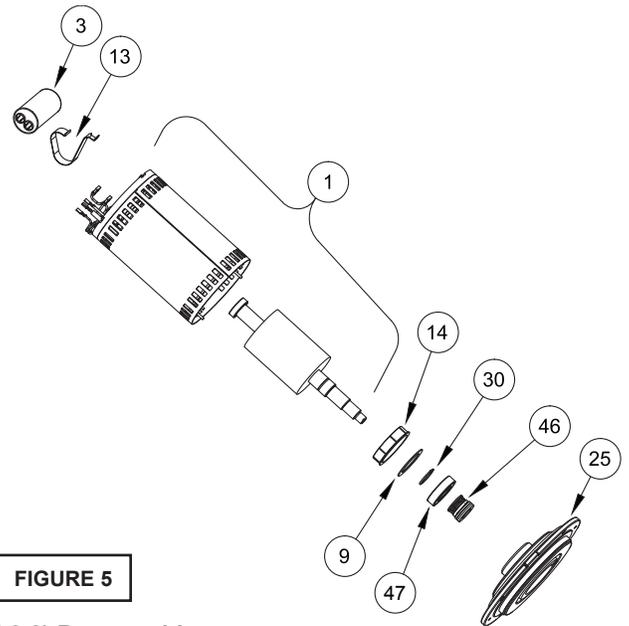

FIGURE 5

F-2.2) Reassembly:

To install impeller (28), apply a thin film of oil to motor shaft and slide impeller straight onto shaft, keeping keyways lined up. Drive key (33) into keyway. Locate washer (35), apply thread locking compound to shaft threads, thread hex nut (34) to shaft and torque to 40 ft. lbs. Rotate impeller to check for binding. Position square ring (42) on volute flange and position impeller and motor housing on volute (26). Install lock washer (19) and nuts (20) on studs (24) in volute (26). Torque to 20 ft. lbs. Check for free rotation of motor and impeller. (See Figure 11 or 13)

F-3) Motor, Bearing and Seal Service

F-3.1) Disassembly and Inspection:

To examine or replace the motor (1), shaft seal (46), and bearing (47), drain oil from motor as outlined in paragraph F-1.2. Disassemble volute and impeller as outlined in paragraph F-2.1. (See Figure 3, 4, and 5)

Position unit upright, using blocks to avoid resting unit on shaft. Unscrew cord hex bolts (6) and remove compression flange (10a) and power cord (10). Remove snap ring (8) with a flat head screwdriver. Pull the terminal block (27) out of the motor housing (2) using a T-bolt or pair of pliers and a .25-20 screw in the threads of the terminal block (27). Be sure to leave slack on the motor leads connected underneath. Use needle nose pliers to pull each female connector off of the pins on the underside of the terminal block (27) (see Figure 6). The unit voltage should be noted. Remove socket head cap screws (39). Vertically lift upper pump assembly from seal plate (25) by lifting handle (7). Inspect square rings (42) for damage or cuts.

Motor - Remove the motor bolts and lift motor stator from motor rotor and seal plate (25). Unscrew conduit bushing (14) from seal plate (25) and lift motor rotor, shaft, bearing (42), rotating portion of seal (46), washer (9) and conduit bushing (14) from seal plate (25).

Inspect windings for shorts and check resistance values. Check rotor for wear, if rotor or the stator windings are defective, the complete motor must be replaced. To test the temperature sensor (if equipped), check the continuity between the black and white wires. If found to be defective contact a motor service station or CP&S Service Department.

Check motor capacitor (3, 1 phase units) with an Ohm meter by first grounding the capacitor by placing a screwdriver across both terminals and then removing screwdriver. Connect Ohm meter (set on high scale) to terminals. If needle moves to infinity (∞) then drifts back, the capacitor is good. If needle does not move or moves to infinity (∞) and does not drift back, replace capacitor (3). To test the temperature sensor (P1/P2), check for continuity between the wire leads (see Figure 10). If found to be defective, contact a motor service station or CP&S Pumps Service department. Inspect motor winding for shorts and check resistance values. Check rotor for wear. If rotor or the stator windings are defective, the complete motor must be replaced.

Important! - Handle seal parts with extreme care. Do Not scratch or mar lapped surfaces.

Seal - Remove rotating member (46a), spring (46c) and retaining ring (46d) from shaft. (see Figure 3). Examine all seal parts and especially contact faces. Inspect seal for signs of wear such as uneven wear pattern on stationary members, chips and scratches on either seal face. **DO NOT** interchange seal components, replace the entire shaft seal (46). If replacing seal, remove stationary (46a) from seal plate (25) by prying out with flat screwdriver.

Bearing - Examine bearing (47) and replace if required. If replacement is required, remove bearing (47) from motor shaft using a wheel puller. Washer (9), retaining ring (30) and conduit bushing (14) can now be removed from motor shaft.

Important! - All parts must be clean before reassembly.

F-3.2) Reassembly:

Bearing - When replacing bearing, be careful not to damage the rotor or shaft threads. Clean the shaft thoroughly. Slide conduit bushing (14) and washer (9) over motor shaft. Insert retaining ring (30) into groove on shaft. Apply adhesive compound to the shaft and press bearing (47) on the motor shaft, position squarely onto shaft applying force to the inner race of the bearing only, until bearing seats against retaining ring (30).

Seal - Clean and oil seal cavity in seal plate (25). Press stationary member (46a) firmly into seal plate (25), using a seal pusher, nothing but the seal pusher is to come in contact with seal face (See Figure 6). Make sure the stationary member is in straight.

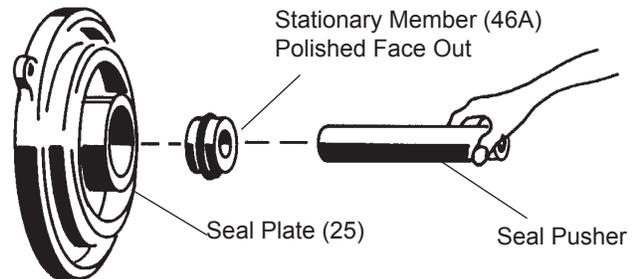

FIGURE 6

Important! - DO NOT hammer on the seal pusher it will damage the seal face.

Slide retaining ring (46d) over shaft and let rest on bearing (47). Place spring (46c) over shaft and let rest on retaining ring (46d). Lightly oil (DO NOT use grease) shaft, bullet and inner surface of bellows on rotating member (46b) (See Figure 7), with lapped surface of rotating member (46b) facing outward, slide over bullet and onto shaft using seal pusher, making sure spring (46c) is seated in retaining ring (46d) and spring (46c) is lined up on rotating member (46b) and not cocked or resting on bellows tail.

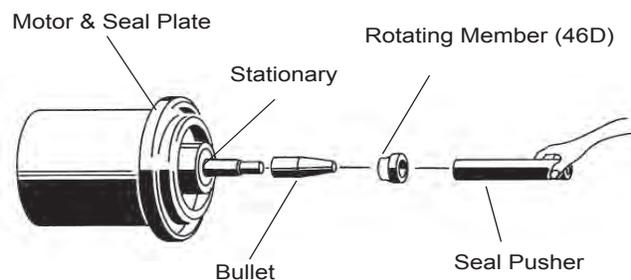

FIGURE 7

Motor - Slide motor rotor with conduit bushing (14), washer (9), bearing (47) and seal parts (46b, c, d) into seal plate (25) until bearing (47) seats in seal plate (25). Center washer (9) on bearing (47) and tighten conduit bushing (14) on seal plate (25). Lower motor stator over rotor until seated in seal plate (25), while aligning holes for motor bolts. Insert motor bolts and torque to 22 inch pounds. If pump is a single phase unit place bracket (15) on one of the motor bolts positioned so capacitor will lay on opposite side of the cord entry bosses of the motor housing (2). Insert capacitor (3) in bracket (15), attach motor leads with terminals to capacitor.

Place all motor leads above motor. Position square ring (42) on seal plate (25) and lower motor housing (2) over motor and into pilot. Place socket head cap screws (39) through seal plate (25) into motor housing (2) and torque to 75 inch pounds. Make wire connections per paragraph F-3.3. Assemble impeller and volute per paragraph F-2.2.

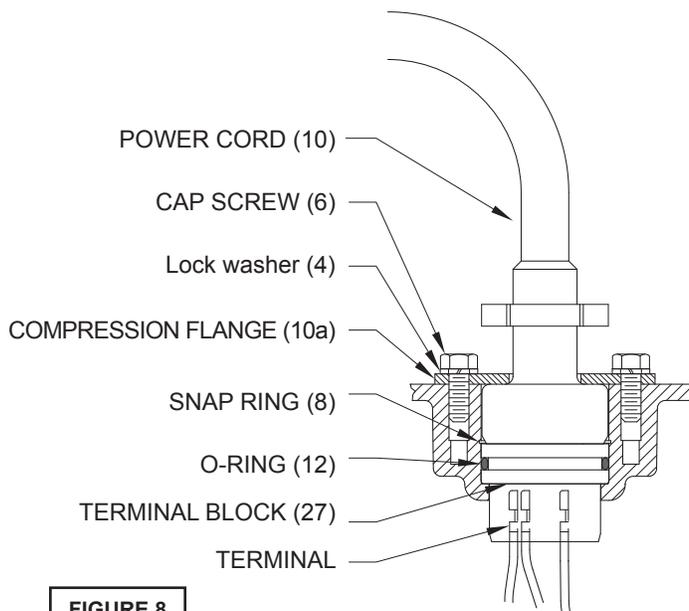

FIGURE 8

F-3.3) Wiring Connections:

Check power cords (10) for cracks or damage and replace if required. Make internal wiring connections which are independent of the terminal block as shown in (Figure 10), using connectors (23) and wire assemblies (29) as required. Do not use wire nuts. Slip motor leads and ground wire through fiberglass sleeve (22). Lower motor housing (2) down onto seal plate (25) while aligning holes and stringing motor leads through the cord entry bore(s). (Slipping cords inside a 1 ft. length of .5" conduit makes this easier). Place socket head cap screws (39) through seal plate (25) into motor housing (2) and torque to 75 in-lbs.

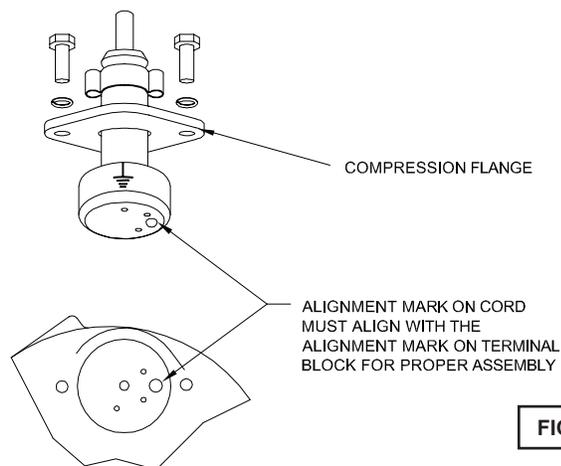

FIGURE 9

Reconnect motor leads to the underside of the terminal block(s) (27) as shown in Figure 8. Note that the pins are numbered underneath the terminal block. Place o-ring (12) into groove in terminal block (27) and lubricate with dielectric oil. Press the terminal block (27) into the housing so it seats completely below the snap ring groove. Place snap ring (8) into groove in cord entry bore of motor housing (2). Repeat terminal block installation for sensor cord, if equipped.

F-3.4) Cord Assemblies:

Power - Refill the cooling oil as outlined in paragraph F-1.4. Make wire connections as outlined in paragraph F-3.3. Insert female end of cord plug into housing bore aligning timing mark with hole in terminal block (27) (see Figure 5). Compress cord plug with compression flange (10a) by tightening cap screws (24) into the motor housing (2). Torque to 132 in-lbs.

SECTION: G REPLACEMENT PARTS

G-1 ORDERING REPLACEMENT PARTS:

When ordering replacement parts, ALWAYS furnish the following information:

1. Pump serial number and date code. (Paragraph G-4)
2. Pump model number. (Paragraph G-3)
3. Pump part number. (Paragraph G-2)
4. Part description.
5. Item part number.
6. Quantity required.
7. Shipping instructions.
8. Billing Instructions.

CRANE PUMPS & SYSTEMS Plus Oilite 105500	HP.	Volts	Code	Ph.	Hz.
	RPM	FLA	Model No.	2	
	Part No.	3		Serial No.	1
	Impeller Dia.	Max. Liq. Temp.	°C	Ins. Class	
	<p>WARNING TO REDUCE RISK OF ELECTRICAL SHOCK DISCONNECT THE PUMP FROM THE POWER SOURCE BEFORE HANDLING OR SERVICING. SEE INSTRUCTION MANUAL FOR PROPER INSTALLATION. SEE WARNING PLATE FOR ADDITIONAL CAUTIONS.</p>				

G-2 PART NUMBER:

The part number consists of a six (6) digit number, which appears in the catalog. A one or two letter suffix may follow this number to designate the design configuration. This number is used for ordering and obtaining information.

G-3 MODEL NUMBER:

This designation consists of numbers and letters which represent the discharge size, series, horsepower, motor phase and voltage, speed and pump design. This number is used for ordering and obtaining information.

G-4 SERIAL NUMBER:

The serial number block will consist of a six digit number, which is specific to each pump and may be preceded by a alpha character, which indicates the plant location. This number will also be suffixed with a four digit number, which indicates the date the unit was built (Date Code). EXAMPLE: A012345 0490.

Reference the six digit portion (Serial Number) of this number when referring to the product.

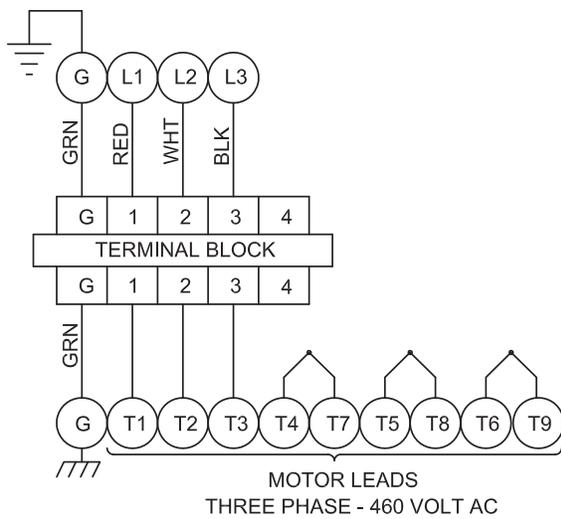
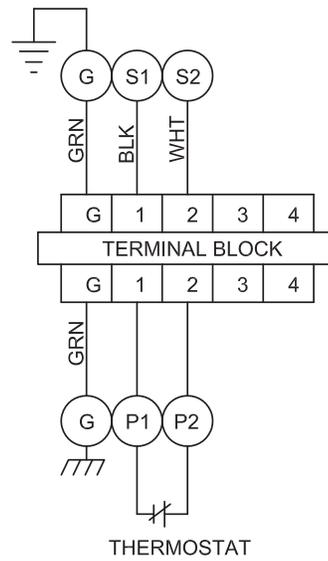
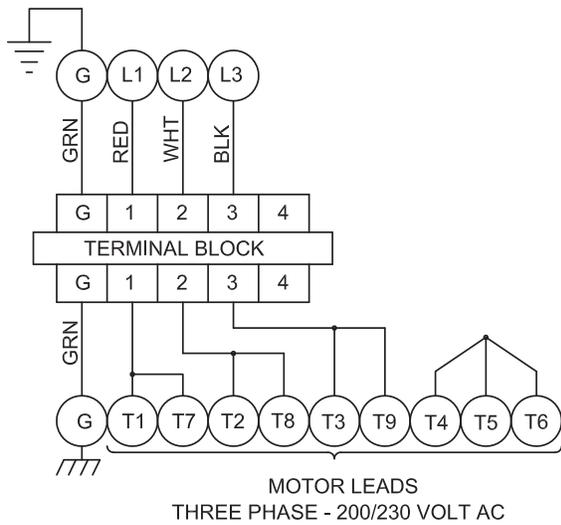
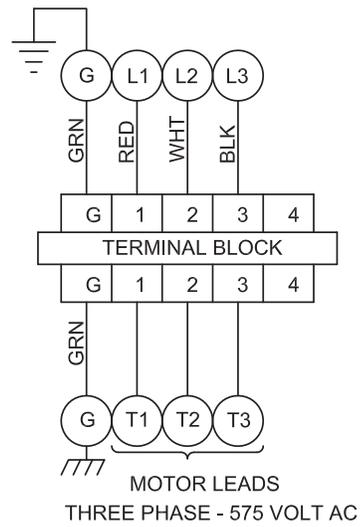
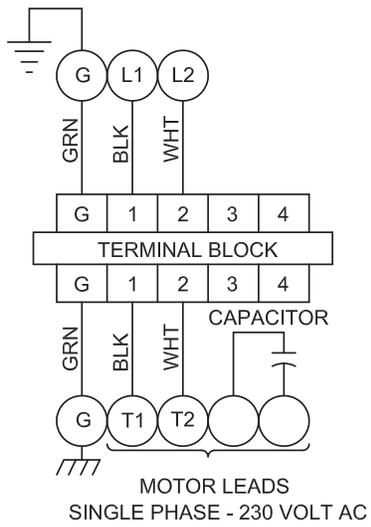

FIGURE 10

TROUBLE SHOOTING

CAUTION ! Always disconnect the pump from the electrical power source before handling.
 If the system fails to operate properly, carefully read instructions and perform maintenance recommendations.
 If operating problems persist, the following chart may be of assistance in identifying and correcting them:
MATCH "CAUSE" NUMBER WITH CORRELATING "CORRECTION" NUMBER.

NOTE: Not all problems and corrections will apply to each pump model.

PROBLEM	CAUSE	CORRECTION
Pump will not run	<ol style="list-style-type: none"> 1. Poor electrical connection, blown fuse, tripped breaker or other interruption of power, improper power supply. 2. Motor or switch inoperative (to isolate cause, go to manual operation of pump). <ol style="list-style-type: none"> 2a. Float movement restricted. 2b. Switch will not activate pump or is defective. 2c. Defective motor 3. Insufficient liquid level. 	<ol style="list-style-type: none"> 1. Check all electrical connections for security. Have electrician measure current in motor leads, if current is within $\pm 20\%$ of locked rotor Amps, impeller is probably locked. If current is 0, overload may be tripped. Remove power, allow pump to cool, then recheck current. 2a. Reposition pump or clean basin as required to provide adequate clearance for float. 2b. Disconnect level control. Set ohmmeter for a low range, such as 100 ohms full scale and connect to level control leads. Actuate level control manually and check to see that ohmmeter shows zero ohms for closed switch and full scale for open switch. (Float Switch). 2c. Check winding insulation (Megger Test) and winding resistance. If check is outside of range, dry and recheck. If still defective, replace per service instructions. 3. Make sure liquid level is at least equal to suggested turn-on point. 4. Recheck all sizing calculations to determine proper pump size. 5. Check discharge line for restrictions, including ice if line passes through or into cold areas. 6. Remove and examine check valve for proper installation and freedom of operation. 7. Open valve. 8. Check impeller for freedom of operation, security and condition. Clean impeller and inlet of any obstruction. 9. Loosen union slightly to allow trapped air to escape. Verify that turn-off level of switch is set so that the suction is always flooded. Clean vent hole. 10. Check rotation. If power supply is three phase, reverse any two of three power supply leads to ensure proper impeller rotation.. 11. Repair fixtures as required to eliminate leakage. 12. Check pump temperature limits & fluid temperature. 13. Replace portion of discharge pipe with flexible connector. 14. Turn to automatic position. 15. Check for leaks around basin inlet and outlets. 16. Inspect motor shaft runout. Inspect bearings. Replace as necessary.
Pump will not turn off	<ol style="list-style-type: none"> 2a. Float movement restricted. 2b. Switch will not activate pump or is defective. 4. Excessive inflow or pump not properly sized for application. 9. Pump may be airlocked 14. H-O-A switch on panel is in "HAND" position 	
Pump hums but does not run	<ol style="list-style-type: none"> 1. Incorrect voltage 8. Impeller jammed or loose on shaft, worn or damaged, impeller cavity or inlet plugged. 	
Pump delivers insufficient capacity	<ol style="list-style-type: none"> 1. Incorrect voltage. 4. Excessive inflow or pump not properly sized for application. 5. Discharge restricted. 6. Check valve stuck closed or installed backwards. 7. Shut-off valve closed. 8. Impeller jammed or loose on shaft, worn or damaged, impeller cavity or inlet plugged. 9. Pump may be airlocked. 10. Pump running backwards 	
Pump cycles too frequently or runs periodically when fixtures are not in use	<ol style="list-style-type: none"> 6. Check valve stuck closed or installed backwards. 11. Fixtures are leaking. 15. Ground water entering basin. 	
Pump shuts off and turns on independent of switch, (trips thermal overload protector). CAUTION! Pump may start unexpectedly. Disconnect power supply.	<ol style="list-style-type: none"> 1. Incorrect voltage. 4. Excessive inflow or pump not properly sized for application. 8. Impeller jammed, loose on shaft, worn or damaged, impeller cavity or inlet plugged. 12. Excessive water temperature. (internal protection only) 	
Pump operates noisily or vibrates excessively	<ol style="list-style-type: none"> 5. Debris in impeller cavity or broken impeller 10. Pump running backwards 13. Piping attachments to building structure too rigid or too loose. 16. Worn bearings, motor shaft bent. 	

3SE-L 3450RPM

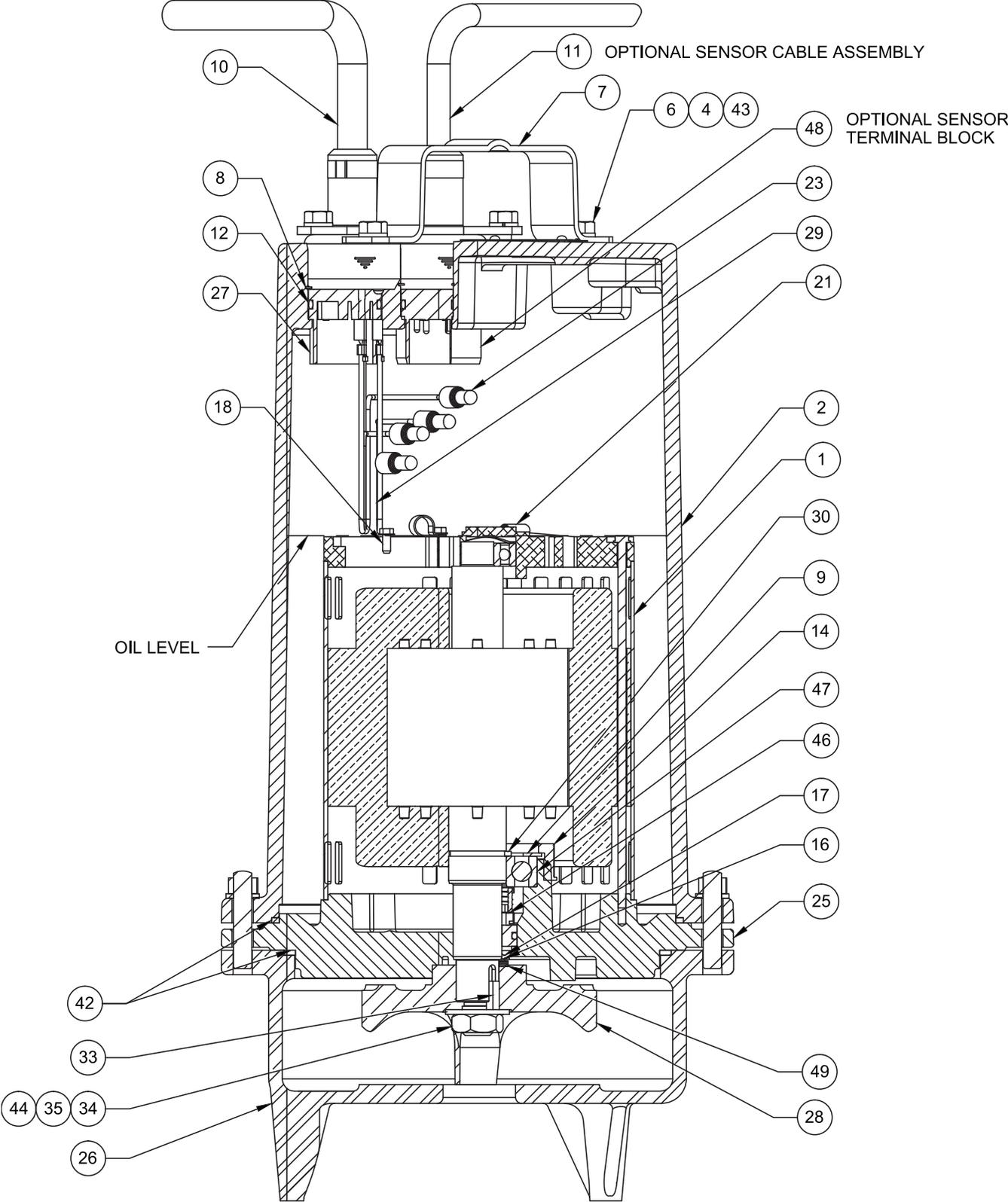

FIGURE 11

3SE-L 3450RPM

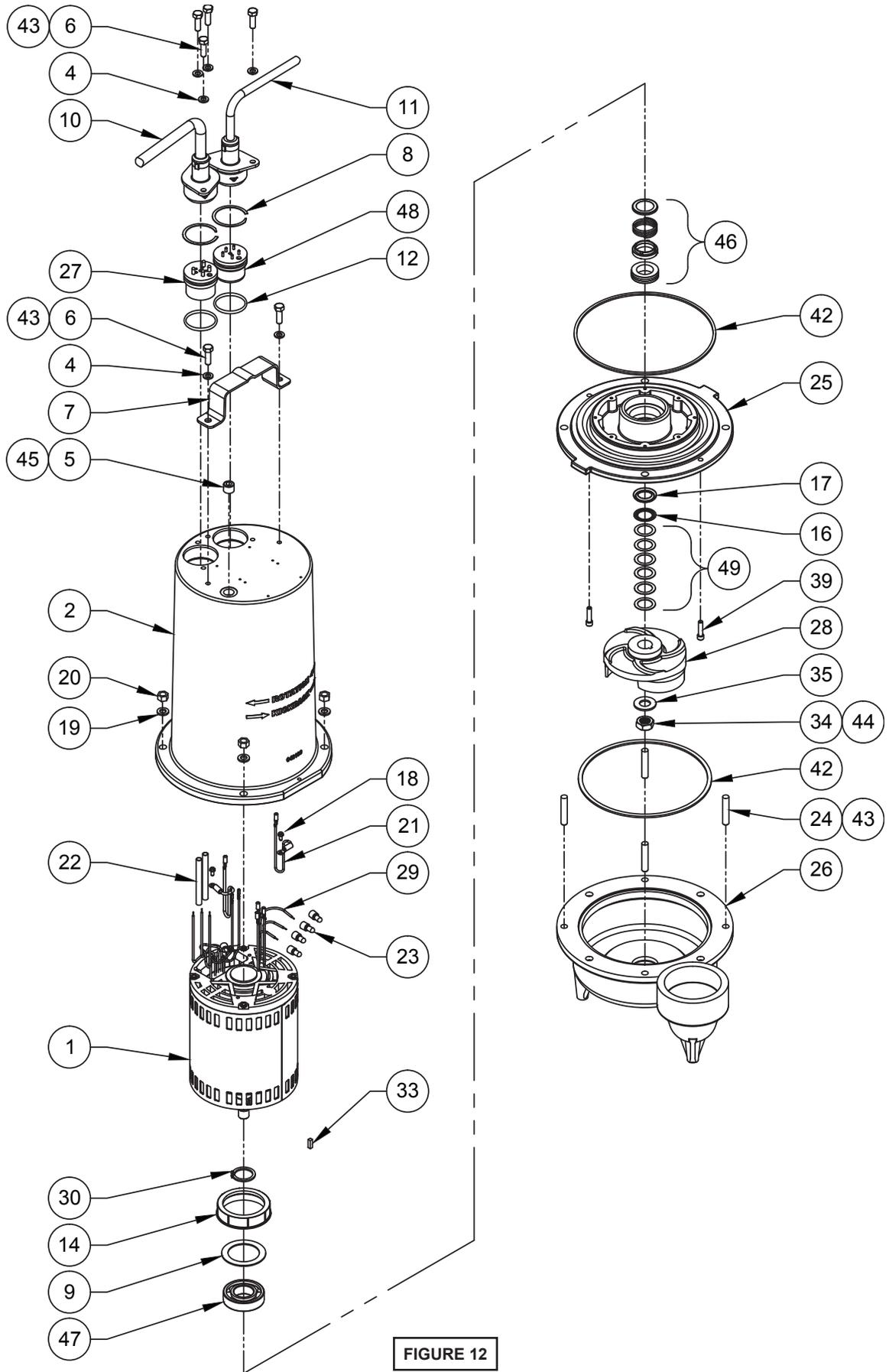

FIGURE 12

3SE-L 3450RPM Pump Series

PARTS KITS

Seal Repair Kit P/N - 130182 (†) 12, 16, 17, 42, 46

Overhaul Kit P/N - 130209 (♦) 8, 12, 16, 17, 30, 33, 34, 35, 42, 46, 47

PARTS LIST

ITEM	QTY	PART NO.	DESCRIPTION	NOTES
1	1	088682	Motor, 3SE3032L, 3SE3042L	
		088684	Motor, 3SE3052L	
2	1	114492	Motor Housing	STD Power Cord
	1	114492HA	Motor Housing	with Optional Sensor Cord
4	4	026322	5/16" Lock washer	SS (STD)
	2	026322	5/16" Lock washer	SS, with Optional Sensor Cord
5	1	014270	3/8" NPT Pipe Plug	ZP
6	4	1-156-1	HXHD Cap Screw	5/16-18 x 1.00" LG, SS (STD)
	2	1-156-1	HXHD Cap Screw	5/16-18 x 1.00" LG, SS, with Optional Sensor Cord
7	1	103503	Handle	
8	1	105197	♦ Retainer Ring	
	1	105197	Retainer Ring	with Optional Sensor Cord
9	1	053756	Washer	1.875 x 2.625, Steel
10	1	See Table 2	Power Cord Assembly	STD
11	1	See Table 2	Sensor Cord Assembly	with Optional Sensor Cord
12	1	2-31051-224	†♦ O-Ring	Buna-N
	1	2-31051-224	†♦ O-Ring	Buna-N with Optional Sensor Cord
13	150 oz.	029034	Oil- Motor Housing	
14	1	053749	Conduit Bushing	
16	1	062641	†♦ Pull Washer	
17	1	061829	†♦ Exclusion Seal	Buna-N
18	1	016660	Self Tap Screw	
19	4	20-14-1	3/8" Lock washer	SS
20	4	15-23-1	3/8-16 Hex Nut	SS
21	1	105111B	Ground Wire	12AWG x 8.00" LG, 230V 3 Phase
	1	105111	Ground Wire	14AWG x 8.00" LG, 460/575V 3 Phase
22	1	625-02117	Fiberglass Sleeve	460/575V 3 Phase
	2	625-02117	Fiberglass Sleeve	230V 3 Phase
23	1	105150	Wire Crimp Connector	230V 3 Phase
	5	105150	Wire Crimp Connector	460V 3 Phase
	4	105150	Wire Crimp Connector	575V 3 Phase
24	4	033824	Stud	3/8-16 x 2.00" LG, SS
25	1	062482	Seal Plate	CI
26	1	067251	Volute	CI
27	1	See Table 2	Power Cord Terminal Block	
28	1		Impeller, Cast Iron	
		088545	5.00" Dia.	
		088545TA	4.87" Dia. (3HP -STD)	
		088545TB	4.75" Dia.	
		088545TC	4.62" Dia.	
		088545TD	4.50" Dia.	
		088545TE	4.37" Dia.	
		088545TF	4.25" Dia.	
		088545TG	4.12" Dia.	
		088545TH	4.00" Dia.	
		088545TJ	3.87" Dia.	
		088545TK	3.75" Dia.	
		088545TL	3.63" Dia.	
		088545TM	3.50" Dia.	
29	3	105149A	Jumper Wire	230V, 3 Phase
30	1	057882	♦ Retaining Ring	
33	1	057554	♦ Shaft Key	.19 x .19 x .575, SS
34	1	038132	♦ 5/8-16 Hex Nut	SS
35	1	070320	♦ 3/8" Flat Washer	SS
39	2	11-32-1	SKHD Cap Screw	1/4-20 x 1.00" LG, SS

3SE-L 3450RPM Pump Series

PARTS LIST

ITEM	QTY	PART NO.	DESCRIPTION	NOTES
42	2	033730	†♦ Square Ring	Buna-N
43	A/R	-----	Loctite Adhesive, #242-41	Blue
44	A/R	-----	Loctite Adhesive, #RC603	Green
45	A/R	-----	Loctite PSP #567	White Pipe Sealant
46	1	062435	†♦ Shaft Seal	Carbon/Ceramic/Buna-N (STD)
		062435SB	Shaft Seal	Tungsten/Tungsten/Buna-N
		062435SD	Shaft Seal	Silicon/Silicon/Buna-N
47	1	053746	♦ Ball Bearing	
48	1	See Table 2	Sensor Cord Terminal Block	with Optional Sensor Cord
49	2	028170	Shim, .005"	(use as required)
	1	026989	Shim, .010"	(use as required)
	3	028121	Shim, .030"	(use as required)

TABLE 2 - POWER AND SENSOR CORD SETS				
MODEL NUMBER	30 FT. POWER	50 FT. POWER	100 FT. POWER	TERMINAL BLOCK POWER
3SE3032L	109492XC	109492XF	109492XL	103586
3SE3042L	103742XC	103742XF	103742XL	103583
3SE3052L	103742XC	103742XF	103742XL	103583
MODEL NUMBER	30 FT. SENSOR	50 FT. SENSOR	100 FT. SENSOR	TERMINAL BLOCK SENSOR
3SE3032L	113288XC	113288XF	113288XL	113272
3SE3042L	113288XC	113288XF	113288XL	113272
3SE3052L	113288XC	113288XF	113288XL	113272

3SE-L 1750RPM

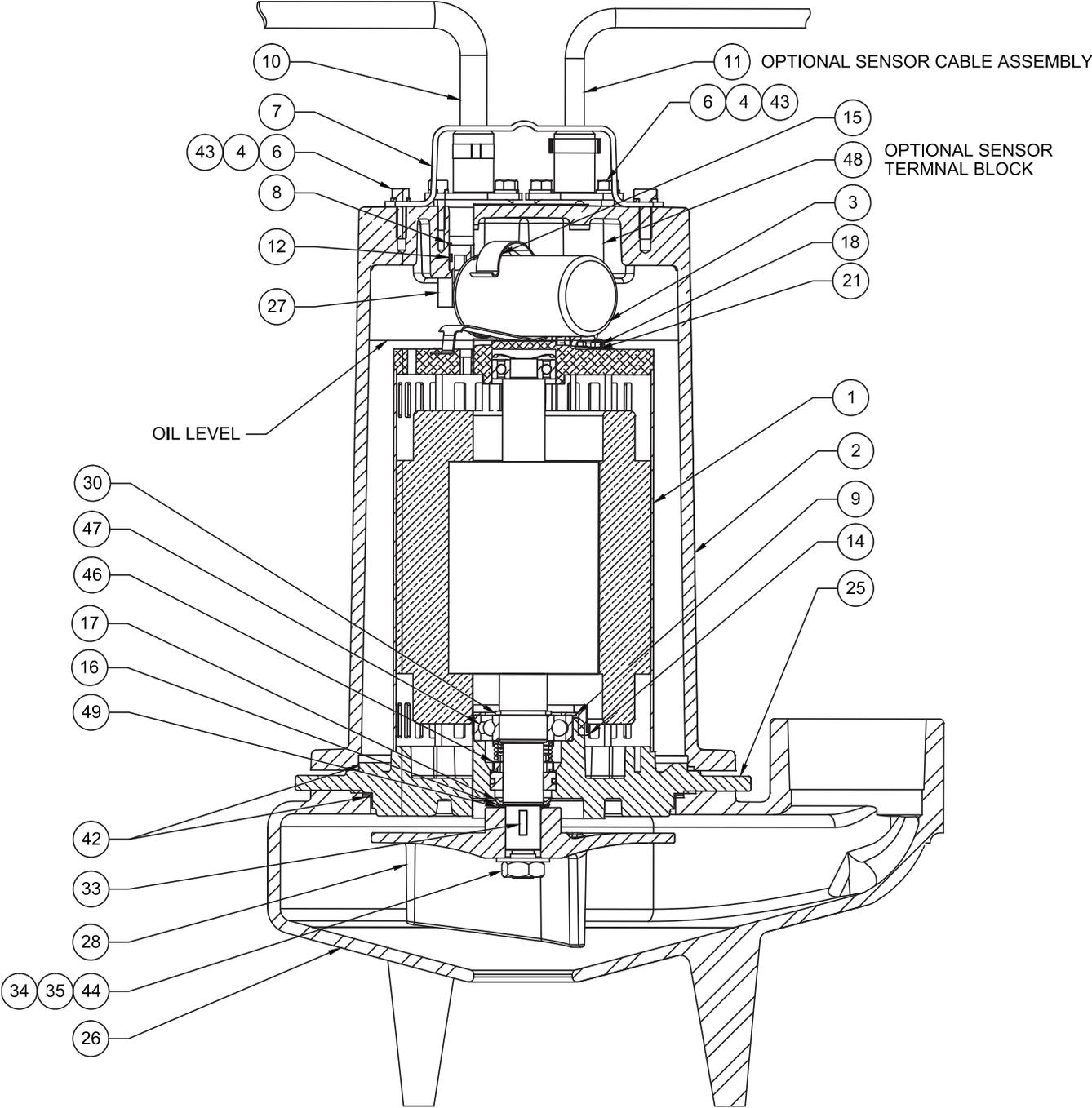

FIGURE 13

3SE-L 1750RPM

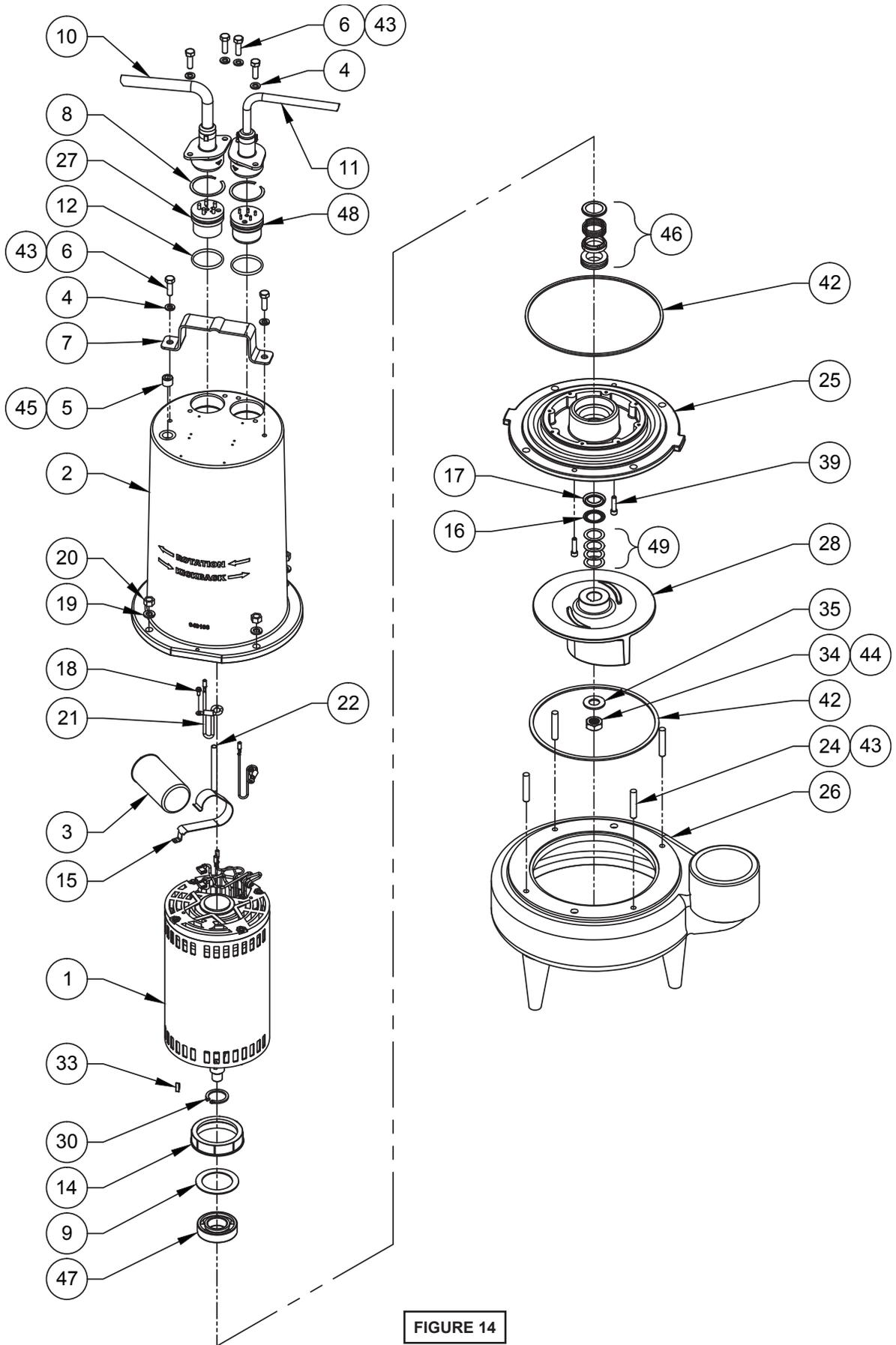

FIGURE 14

3SE-L 1750RPM Pump Series

PARTS KITS

Seal Repair Kits

Single Seal.....P/N - **130182** (†) 12, 16, 17, 42, 46

Service Kits

Single Seal.....P/N - **130209** (♦) 8, 12, 16, 17, 30, 33, 34, 35, 42, 46, 47

PARTS LIST

ITEM	QTY	PART NO.	DESCRIPTION	NOTES
1	1	088700	Motor, 3SE3024L	
		088703	Motor, 3SE3034L, 3SE3044L	
		088705	Motor, 3SE3054L	
2	1	114492	Motor Housing	STD
	1	114492HA	Motor Housing	with Optional Sensor Cord
3	1	036391	Capacitor,	370V, 45MFD
4	4	026322	5/16" Lock washer	SS (STD)
	2	026322	5/16" Lock washer	SS, with Optional Sensor Cord
5	1	014270	3/8" NPT Pipe Plug	ZP
6	4	1-156-1	HXHD Cap Screw	5/16-18 x 1.00 LG, SS (STD)
	2	1-156-1	HXHD Cap Screw	5/16-18 x 1.00 LG, SS, with Optional Sensor Cord
7	1	103503	Handle	
8	1	105197	♦ Retaining Ring	(STD)
	2	105197	♦ Retaining Ring	with Optional Sensor Cord
9	1	053756	Washer	1.875 x 2.625 Steel
10	1	See Table 3	Power Cord	(STD)
11	1	See Table 3	Optional Sensor Cord	
12	1	2-31051-224	†♦ O-Ring	Buna-N
13	150 oz.	029034	Oil- Motor Housing	
14	1	053749	Conduit Bushing	
15	1	133495	Bracket, Capacitor	
16	1	062641	†♦ Pull Washer	
17	1	061829	†♦ Exclusion Seal	
18	1	016660	Self-Tap Screw	
19	4	20-14-1	3/8" Lock washer	SS
20	4	15-23-1	3/8-16 Hex Nut	SS
21	1	105111A	Ground Wire, Green	10AWG x 8.00" LG, 230V, 1 Phase
	1	105111B	Ground Wire, Green	12AWG x 8.00" LG, 230V, 3 Phase
	1	105111	Ground Wire, Green	14AWG x 8.00" LG, 460/575V, 3 Phase
22	1	625-02117	Fiberglass Sleeve	230V, 1 Phase, 460/575V, 3 Phase
	2	625-02117	Fiberglass Sleeve	230V, 3 Phase
23	1	105150	Wire Crimp Connector	575V, 3 Phase
	5	105150	Wire Crimp Connector	230V, 3 Phase
	4	105150	Wire Crimp Connector	460V, 3 Phase
24	4	033824	Stud	3/8-16 x 2.00" LG, SS
25	1	062482	Seal Plate	CI
26	1	062640	Volute	CI
27	1	See Table 3	Power Cord Terminal Block	
28	1		Impeller, Cast Iron	
		088534	7.50" Dia. (3HP-STD)	
		088534TA	7.38" Dia.	
		088534TB	7.25" Dia.	
		088534TC	7.12" Dia.	
		088534TD	7.00" Dia.	
		088534TE	6.88" Dia.	
		088534TF	6.75" Dia.	
		088534TG	6.62" Dia.	
		088534TH	6.50" Dia.	
		088534TJ	6.38" Dia.	
		088534TK	6.275" Dia.	
		088534TL	6.12" Dia.	
		088534TM	6.00" Dia.	
		088534TN	5.88" Dia.	
		088534TP	5.75" Dia.	
		088534TQ	5.62" Dia.	

3SE-L 1750RPM Pump Series

PARTS LIST

ITEM	QTY	PART NO.	DESCRIPTION	NOTES
29	3	105149A	Jumper Wire	230V, 3 Phase
30	1	057882	◆ Retaining Ring	
33	1	035589	◆ Shaft Key	#61 x .187
34	1	038132	◆ Hex Nut	5/8-18 SS
35	1	070320	◆ 5/8" Flat Washer	SS
39	2	11-32-1	SKHD Cap Screw	1/4-20 x 1.00" LG, SS
42	2	033730	†◆ Square Ring	
43	A/R	-----	Loctite Adhesive, #242-41	Blue
44	A/R	-----	Loctite Adhesive, #RC603	Green
45	A/R	-----	Loctite PST #567	White Pipe Sealant
46	1	062435	†◆ Shaft Seal	Carbon/Ceramic/Buna-N (STD)
		062435SB	Shaft Seal	Tungsten/Tungsten/Buna-N
		062435SD	Shaft Seal	Silicon/Silicon/Buna-N
47	1	053746	◆ Ball Bearing	
48	1	See Table 3	Optional Sensor Cord Terminal Block	
49	2	026989	Shims, .005"	(use as required)
	2	028120	Shims, .010"	(use as required)

TABLE 3 - POWER AND SENSOR CORD SETS

MODEL NUMBER	30 FT. POWER	50 FT. POWER	100 FT. POWER	TERMINAL BLOCK POWER
3SE3024L	103769XC	103769XF	103769XL	103760
3SE3034L	109492XC	109492XF	109492XL	103586
3SE3044L	103742XC	103742XF	103742XL	103583
3SE3054L	103742XC	103742XF	103742XL	103583
MODEL NUMBER	30 FT. SENSOR	50 FT. SENSOR	100 FT. SENSOR	TERMINAL BLOCK SENSOR
3SE3024L	-----	-----	-----	-----
3SE3034L	113288XC	113288XF	113288XL	113272
3SE3044L	113288XC	113288XF	113288XL	113272
3SE3054L	113288XC	113288XF	113288XL	113272

BARNES[®]

BARNES[®]
PRESSURE **PS** SYSTEMS



burks[®]

WEINMAN[®]

DEMING[®]

PROSSER[®]

Limited 24 Month Warranty

Crane Pumps & Systems warrants that products of our manufacture will be free of defects in material and workmanship under normal use and service for twenty-four (24) months after manufacture date, when installed and maintained in accordance with our instructions. This warranty gives you specific legal rights, and there may also be other rights which vary from state to state. In the event the product is covered by the Federal Consumer Product Warranties Law (1) the duration of any implied warranties associated with the product by virtue of said law is limited to the same duration as stated herein, (2) this warranty is a LIMITED WARRANTY, and (3) no claims of any nature whatsoever shall be made against us, until the ultimate consumer, his successor, or assigns, notifies us in writing of the defect, and delivers the product and/or defective part(s) freight prepaid to our factory or nearest authorized service station. Some states do not allow limitations on how long an implied warranty lasts, so the above limitation may not apply. **THE SOLE AND EXCLUSIVE REMEDY FOR BREACH OF ANY AND ALL WARRANTIES WITH RESPECT TO ANY PRODUCT SHALL BE TO REPLACE OR REPAIR AT OUR ELECTION, F.O.B. POINT OF MANUFACTURE OR AUTHORIZED REPAIR STATION, SUCH PRODUCTS AND/OR PARTS AS PROVEN DEFECTIVE. THERE SHALL BE NO FURTHER LIABILITY, WHETHER BASED ON WARRANTY, NEGLIGENCE OR OTHERWISE.** Unless expressly stated otherwise, guarantees in the nature of performance specifications furnished in addition to the foregoing material and workmanship warranties on a product manufactured by us, if any, are subject to laboratory tests corrected for field performance. Any additional guarantees, in the nature of performance specifications must be in writing and such writing must be signed by our authorized representative. Due to inaccuracies in field testing if a conflict arises between the results of field testing conducted by or for user, and laboratory tests corrected for field performance, the latter shall control. **RECOMMENDATIONS FOR SPECIAL APPLICATIONS OR THOSE RESULTING FROM SYSTEMS ANALYSES AND EVALUATIONS WE CONDUCT WILL BE BASED ON OUR BEST AVAILABLE EXPERIENCE AND PUBLISHED INDUSTRY INFORMATION. SUCH RECOMMENDATIONS DO NOT CONSTITUTE A WARRANTY OF SATISFACTORY PERFORMANCE AND NO SUCH WARRANTY IS GIVEN.**

This warranty shall not apply when damage is caused by (a) improper installation, (b) improper voltage (c) lightning (d) excessive sand or other abrasive material (e) scale or corrosion build-up due to excessive chemical content. Any modification of the original equipment will also void the warranty. We will not be responsible for loss, damage or labor cost due to interruption of service caused by defective parts. Neither will we accept charges incurred by others without our prior written approval.

This warranty is void if our inspection reveals the product was used in a manner inconsistent with normal industry practice and/or our specific recommendations. The purchaser is responsible for communication of all necessary information regarding the application and use of the product. **UNDER NO CIRCUMSTANCES WILL WE BE RESPONSIBLE FOR ANY OTHER DIRECT OR CONSEQUENTIAL DAMAGES, INCLUDING BUT NOT LIMITED TO TRAVEL EXPENSES, RENTED EQUIPMENT, OUTSIDE CONTRACTOR FEES, UNAUTHORIZED REPAIR SHOP EXPENSES, LOST PROFITS, LOST INCOME, LABOR CHARGES, DELAYS IN PRODUCTION, IDLE PRODUCTION, WHICH DAMAGES ARE CAUSED BY ANY DEFECTS IN MATERIAL AND/OR WORKMANSHIP AND/OR DAMAGE OR DELAYS IN SHIPMENT. THIS WARRANTY IS EXPRESSLY IN LIEU OF ANY OTHER EXPRESS OR IMPLIED WARRANTY, INCLUDING ANY WARRANTY OF MERCHANTABILITY OR FITNESS FOR A PARTICULAR PURPOSE.**

No rights extended under this warranty shall be assigned to any other person, whether by operation of law or otherwise, without our prior written approval.

CRANE[®]

PUMPS & SYSTEMS

A Crane Co. Company

420 Third Street
Piqua, Ohio 45356
Phone: (937) 778-8947
Fax: (937) 773-7157
www.cranepumps.com

83 West Drive, Brampton
Ontario, Canada L6T 2J6
Phone: (905) 457-6223
Fax: (905) 457-2650

**IMPORTANT!
WARRANTY REGISTRATION**

Your product is covered by the enclosed Warranty.
To complete the Warranty Registration Form go to:

<http://www.cranepumps.com/ProductRegistration/>

If you have a claim under the provision of the warranty, contact your local
Crane Pumps & Systems, Inc. Distributor.

RETURNED GOODS

**RETURN OF MERCHANDISE REQUIRES A "RETURNED GOODS AUTHORIZATION".
CONTACT YOUR LOCAL CRANE PUMPS & SYSTEMS, INC. DISTRIBUTOR.**



**Products Returned Must Be Cleaned, Sanitized,
Or Decontaminated As Necessary Prior To Shipment,
To Insure That Employees Will Not Be Exposed To Health
Hazards In Handling Said Material. All Applicable Laws
And Regulations Shall Apply.**

