

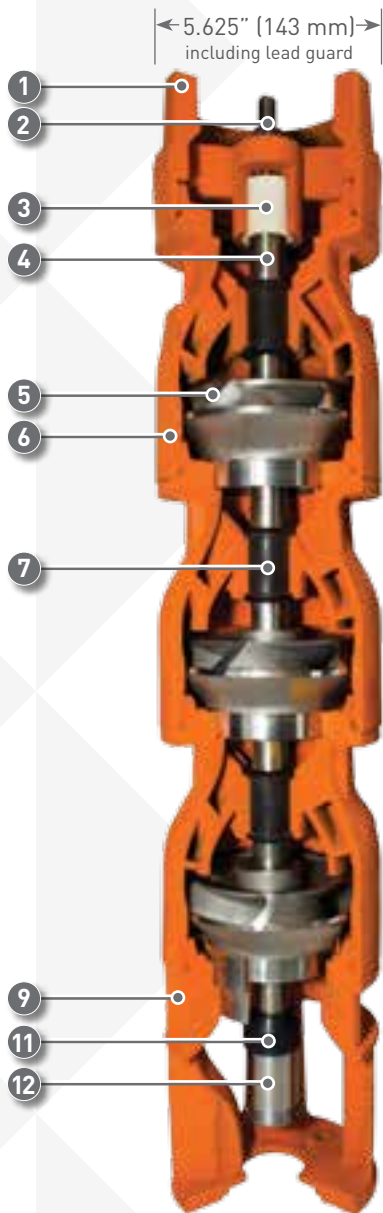

BERKELEY® 5TMH SERIES SUBMERSIBLE TURBINE PUMPS

The 5TMH pump series features abrasion and corrosion resistant materials for maximum performance and longevity under the toughest operating conditions, and delivers industry-leading efficiencies and head per stage.



- 1 Discharge – Ductile iron ASTM 536-84**
Threaded with large wrench flats and sized for the pump's flow range
- 2 Upthrust nut / screw - 304 Stainless Steel**
Factory pre-set upthrust screw is retained by a stainless steel lockout, providing maximum upthrust protection.
- 3 Discharge bearing - Vesconite®**
Low friction, no water swell, long life. Specific for water-immersed applications, clean or dirty
- 4 Shaft - 416 stainless steel**
Precision ground and polished for reduced running friction and increased service life
- 5 Impeller - 304 stainless steel, investment cast**
Smooth and efficient performance, long life
- 6 Bowls - Class 30 cast iron**
Heavy-walled construction incorporates precision hydraulic design for maximum efficiency and performance. Coated internal passageways on the 5TMH series increases overall pump efficiency and performance.
- 7 Isolator bearings - neoprene**
Unique design channels abrasives away from the stainless steel shaft bearing journal.
- 8 Lead guard - 302 stainless steel**
Protects the motor leads across the full length of the pump (not shown)
- 9 Suction bracket - Ductile iron ASTM 536-84**
Machined for both 4" and 6" motor registers. Designed to effectively divert debris away from the spline engagement area, maximizing durability.
- 10 Suction screen – 304 stainless steel**
Form fitted, provides corrosion resistance, and prevents particulates larger than .19" (4.8 mm) from entering the pump (not shown).
- 11 Sand boot - Buna-N (nitrile rubber)**
Protects coupling and motor splines from abrasive wear.
- 12 Motor coupling - 416 stainless steel**
Fully machined for positive fit; highly corrosion resistant

Vesconite® is a registered trademark of Virginia Engineering Services (Pty) Limited. Berkeley® and Pentair are registered trademarks of Pentair Ltd.



BERKELEY® 5TMH SERIES SUBMERSIBLE TURBINE PUMPS

BEC2 ELECTRONIC CATALOG

Powerful pump selection and application software.
Visit www.berkeleypumps.com
and click the BEC2 icon to get started.

Materials of Construction

Part Name	Material	Reference
shaft, motor coupling	416 stainless steel	AISI 416 stainless steel
bowls	Class 30 cast iron	ASTM Class 30
impeller, suction screen, upthrust screw and nut	304 stainless steel	AISI 304 stainless steel

Part Name	Material	Reference
lead guard	302 stainless steel	AISI 302 stainless steel
motor bracket, discharge	ductile iron	ASTM A536-84 65-45-12
sand boot	Buna-N (nitrile rubber)	
isolator bearings	neoprene	
discharge bearing	Vesconite®	

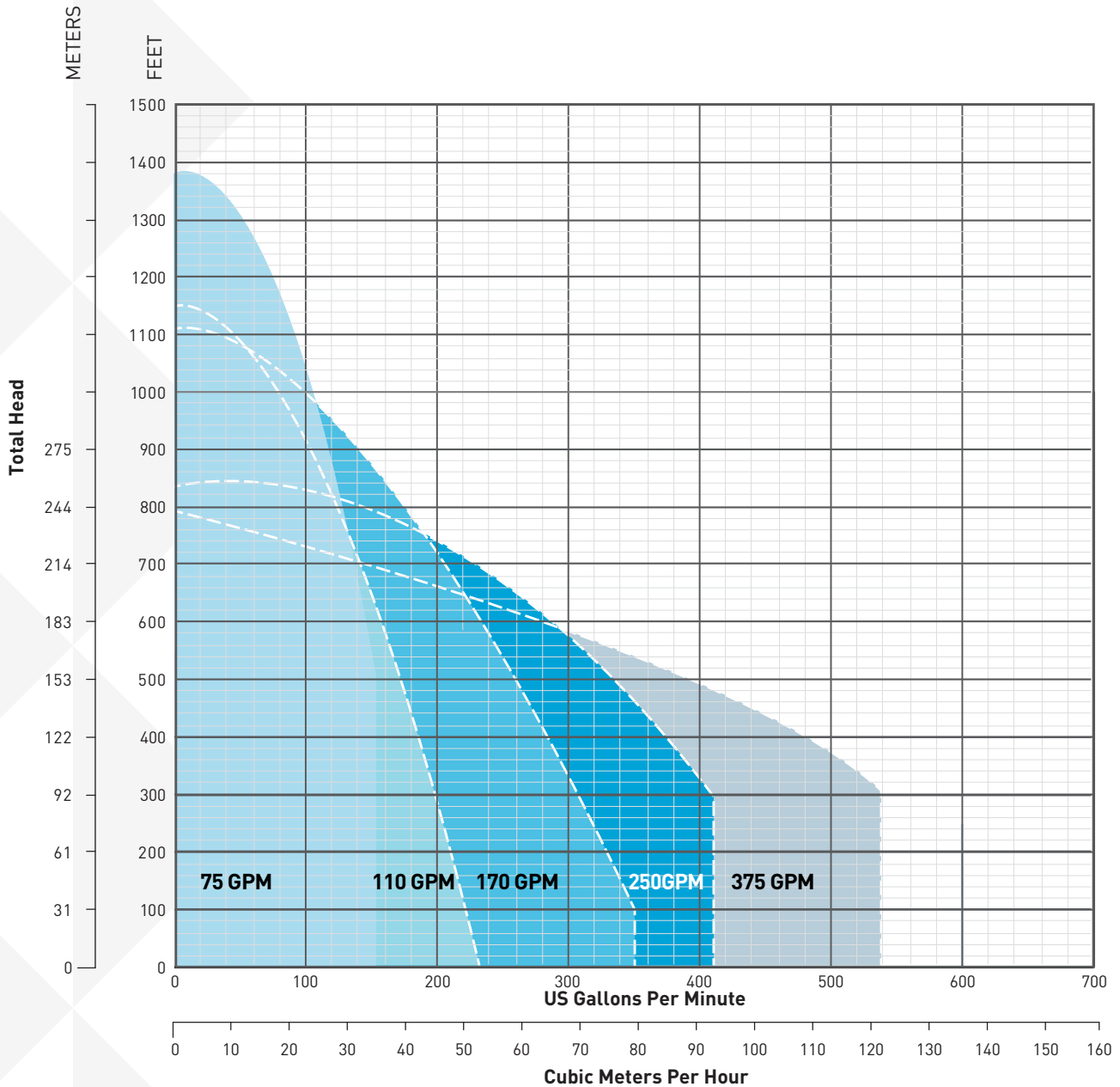

293 WRIGHT STREET, DELAVAN, WI 53115 www.BerkeleyPumps.com
PH: 888-237-5353 ORDERS FAX: 800-321-8793

Vesconite® is a registered trademark of Virginia Engineering Services (Pty) Limited. All other brand or product names are trademarks or registered trademarks of Pentair. Because we are continuously improving our products and services, Pentair reserves the right to change specifications without prior notice.