

Shaft Replacement Kit

BERKELEY®

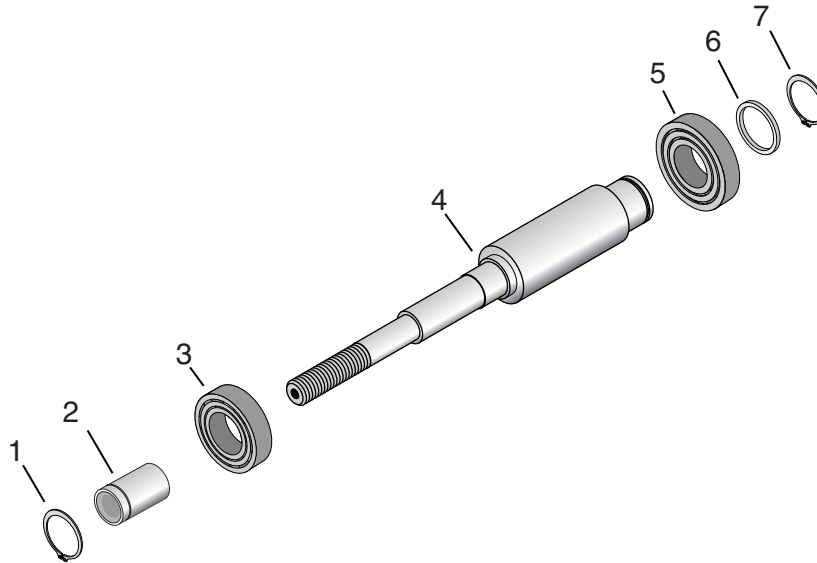

GENERAL

Unpack shaft replacement kit and compare contents with the parts list below. Verify kit received is the correct rotation for your operation. Kit for pump with **clockwise** rotation will have **right hand** threads. Kit for pump with **counterclockwise** rotation will have **left hand** threads.

California Proposition 65 Warning

⚠ WARNING This product and related accessories contain chemicals known to the State of California to cause cancer, birth defects or other reproductive harm.

PARTS LIST

Ref. No.	Part Description	Qty.	Hyd. Z B3ZRM CCW Shaft Kit B80518	Hyd Z B4ZRK B3ZRM CW Shaft Kit B80519
1	Retaining Ring	1	M12486	M12486
2	Shaft Sleeve	1	S05127	S05127
3	Bearing	1	M12394	M12394
4	Shaft	1	1000000879	1000000880
5	Bearing	1	M12395	M12395
6	Thrust Ring	1	M12392	M12392
7	Retaining Ring	1	M12487	M12487

Order Online: www.PumpCatalog.com

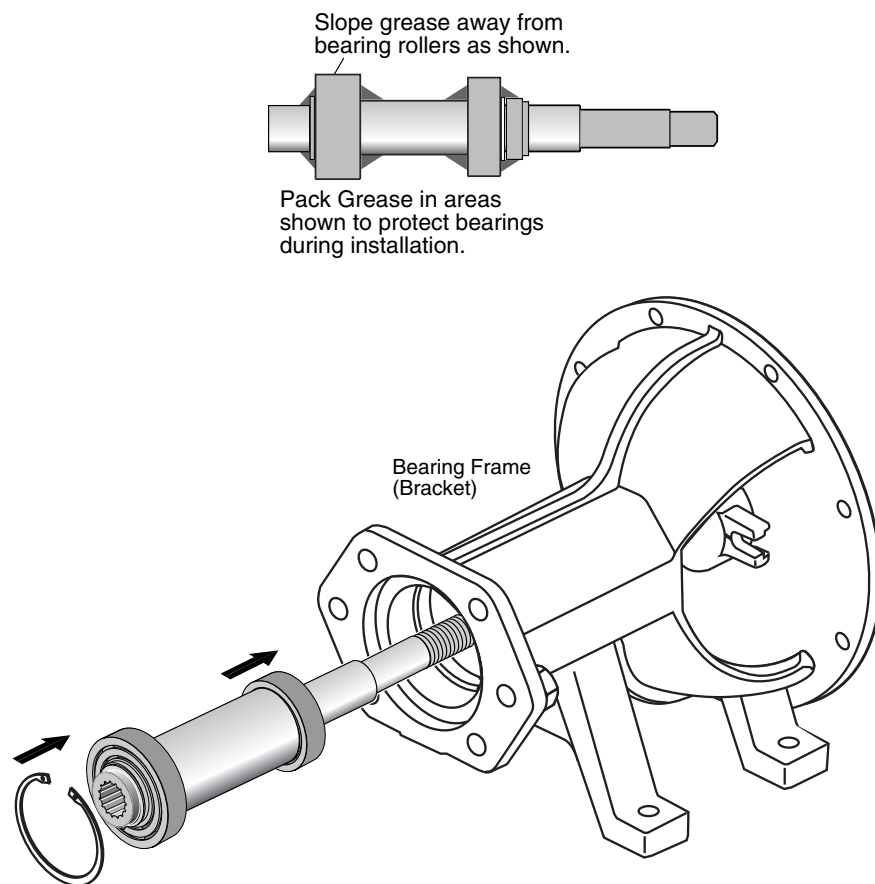

INSTALLATION

1. Thoroughly steam clean or solvent wash the bearing cavity of bearing bracket to remove old grease and dirt. Check surface of bracket for cracks, extreme corrosion, or other defects that may make replacement of the bracket necessary.
2. Pack bearings with a lithium based NGLI No. 2 extra pressure ball bearing grease. Force enough grease into each bearing to fill internal space between the races.
3. Coat the bearing bores of bracket with oil. Orient shaft kit in the direction shown above. Protect the bearings from contamination during installation by applying grease around bearings as shown. Slide shaft and bearing assembly into bearing bracket. When threaded end of pump shaft comes through inner bearing cap, place slinger and lantern ring over end of shaft. If packing gland is not of the split variety, place it over the shaft at this time as well. Slide shaft on through stuffing box until the first bearing makes contact with the bracket. Carefully align bearing with the bearing bore and press or tap bearing assembly into place. **Do not use excessive force.**
4. Screw outer bearing cap tightly against outer bearing race of double row bearing.
5. Inject grease into grease fittings to fill cavities behind bearings.
6. Reassemble pump parts and install unit. Refer to pump owners manual for correct installation procedures.