

# Model FT15ZA Metallic

AIR OPERATED DOUBLE DIAPHRAGM PUMPS

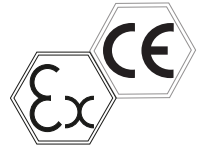
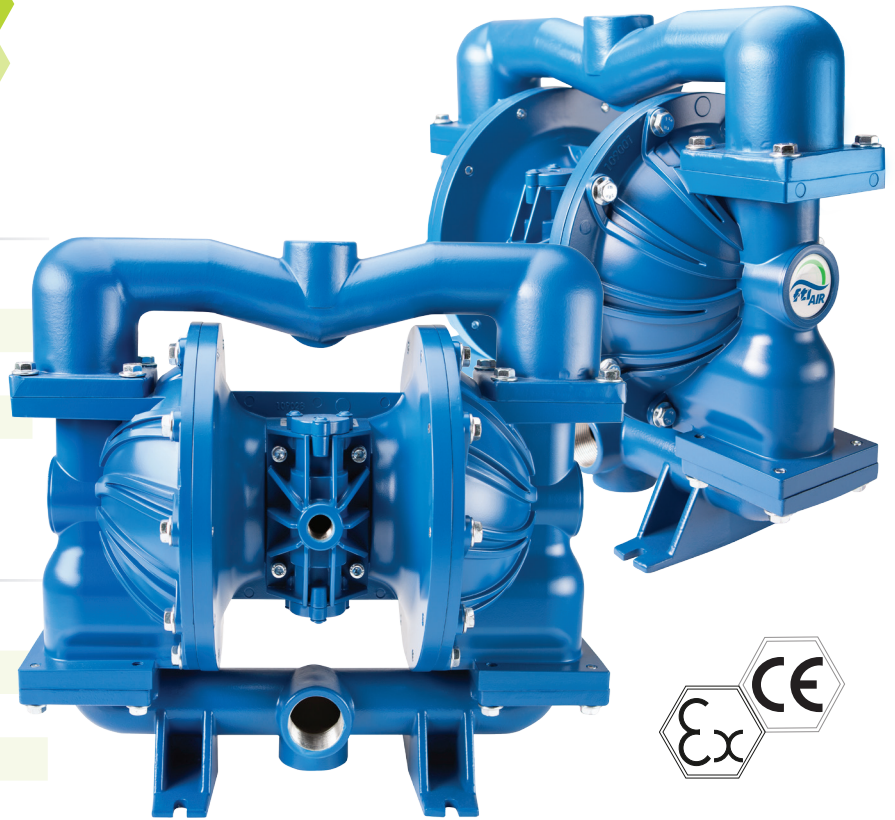

## Specifications

Suction & Discharge Size:	1.5" x 1.5"
Porting Location:	Center Horizontal
Connection Types:	FNPT, FBSPT
Air Inlet & Air Exhaust Size:	1/2" FNPT x 3/4" FNPT

\*Optional NPT or BSP threaded center port location in vertical position

## Capabilities

Maximum Flow Rate:	133 gpm (503 lpm)
Maximum Air Supply Pressure:	120 psi (8.3 bar)
Displacement Per Stroke:	0.24 gal (0.91 lit)
Minimum Air Inlet Pressure:	10 psig (0.7 bar)
Maximum Particle Size :	0.38 in (9.7 mm)
Sound Pressure:	77 dB(A)
Operating temperature:	Determined by elastomers

## FT15Z Performance

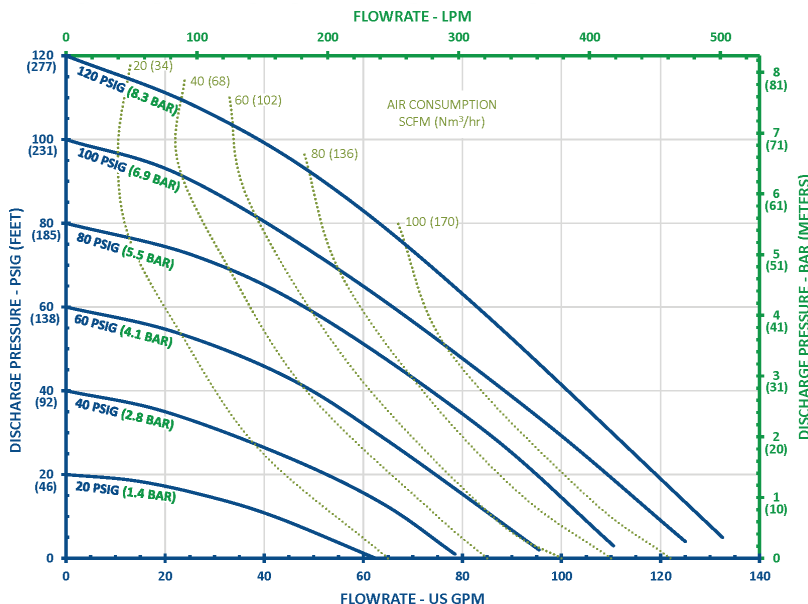

Note: Full stroke diaphragm allows performance to be equal for all elastomers.

## Typical Applications

- Acids & Bases
- Plating Solutions
- Wastewater
- Paints, Inks, Solvents
- Ceramic Slip and Glaze
- Lubricants and Oils

## Typical Industries

- Mining
- Paints and Coatings
- Ceramics
- Pulp and Paper
- Electroplating & Anodizing
- Wastewater
- Marine
- Chemical Manufacturing & Distribution
- OEM's

# CHANGE IS IN THE AIR

## Construction

Wetted Materials:	Aluminum
Diaphragm Materials:	Neoprene, Santoprene™, FKM, EPDM, PTFE, Buna, Hytrel®, Polyurethane
Air Valve:	GFRPP, Aluminum
Ball Materials:	Neoprene, Buna, EPDM, FKM, Santoprene™, PTFE, 316SS
Seat Materials:	Aluminum, 316SS, PTFE, Hytrel, Buna, Neoprene, EPDM, FKM, Santoprene™, Polyurethane
O-ring Materials:	Neoprene, Buna, EPDM, FKM, PTFE, FEP/FKM, Polyurethane, Santoprene™

Santoprene™ is a registered trademark of Exxon Mobil Corp.  
Hytrel® is a registered trademark of Dupont™

## Dimensions

Maximum Height:	17-1/2 in (445 mm)
Maximum Width:	19-7/16 in (494 mm)
Maximum Depth:	11-13/32 in (290 mm)

## Weight

Aluminum: 52 lb (23.6 kg)

**BOTTOM VIEW**

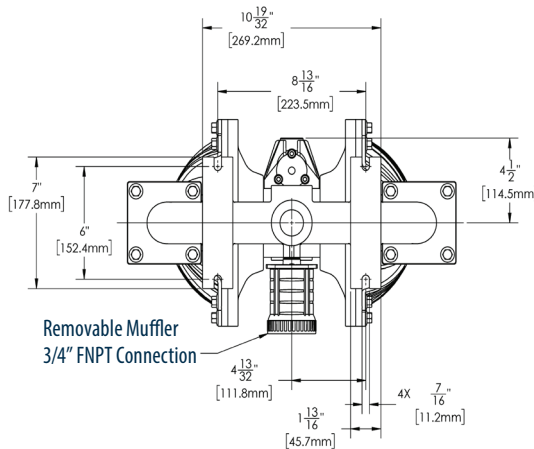

**SIDE VIEW**

