



# GFE Series

CAST IRON EFFLUENT PUMP

## FEATURES

- Cast iron motor housing allowing for optimal heat dissipation
- Premium mechanical seal design provides superior protection against sand and abrasive damage (Silicon Carbide/Silicon Carbide/BUNA)
- Engineered motor designed for peak hydraulic performance without overloading
- Durable cast iron base for stability
- Cast iron impeller with dual vanes. Balanced for smooth operation. ( $\frac{3}{4}$  HP, high head is glass reinforced thermoplastic.)
- Corrosion resistant hardware for lifetime use
- Capable of running dry without damage to components
- Designed for continuous operation when fully submerged
- All models have NEMA three prong grounding plugs
- Available in automatic and manual models

- Approved for residential use (CSA/CUS Listed)
- 3 year warranty

## APPLICATIONS

Specifically designed for the following uses:

- Homes
- Farms
- Trailer courts
- Motels
- Schools
- Hospitals
- Small business
- Effluent systems



Order Online: [www.PumpCatalog.com](http://www.PumpCatalog.com)

**PRODUCT SPECIFICATIONS**

Part No.	HP	Volts	Max. Amps	Locked Rotor Amps	Min. Circuit Breaker	Phase	RPM	Impeller Diameter (in.)	Float Switch Style	Cord Length (ft.)	Power Cable Size	Discharge Connection (in.)	Max. Solids Size	Shipping Weight (lbs.)
GFE0511	1/2	115	14.5	46.0				3.56	Vertical	20'				64.5
GFE0511M				46.0				Not Supplied						
GFE0712	3/4	230	10	27.5	15A	1	3400	4.32	Vertical	20'				67.5
GFE0712M				27.5				Not Supplied						
GFE0712M30				27.5					30'	14/3	1.5" or 2" NPT	3/4"	64.5	
GFE0712 30				27.5				Vertical						
GFE1012	1	230	12.5	36.2					4.67	Vertical	20'			
GFE1012M				36.2				Not Supplied						
GFE1012M30				36.2					30'	14/3	1.5" or 2" NPT	3/4"	67.5	
GFE1012 30				36.2				Vertical						

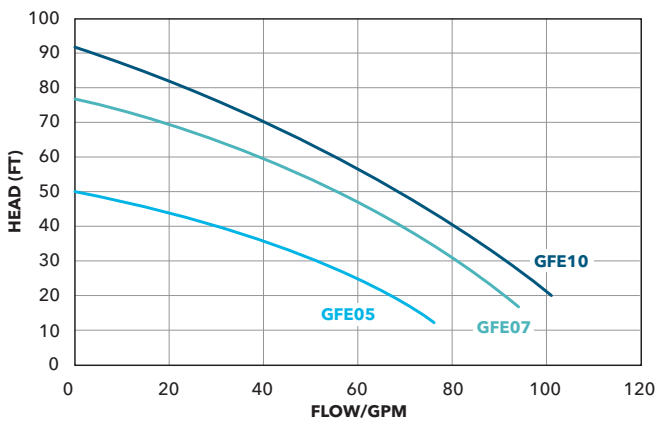
**PERFORMANCE CURVE**

**DIMENSIONS**

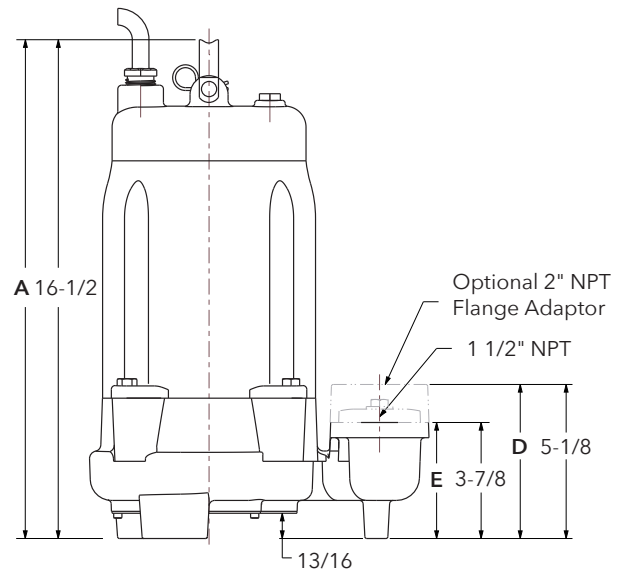
	A	B	C	D	E
<b>All Models</b>	16 1/2"	11 1/4"	7 7/8"	5 1/8"	3 7/8"

**MATERIALS OF CONSTRUCTION**

Part Name	Material
Impeller	Cast Iron*
Casing	Cast Iron Motor Housing
Motor Adapter	Cast Iron
Mechanical Seal	Silicon Carbide/Silicon Carbide/BUNA
Cord	SJTOW
Mechanical Switch	cURus listed, 15A, 125V
Fasteners	Stainless Steel
Handle	Stainless Steel
Float Bracket	Stainless Steel

\* 3/4 HP, high head is glass reinforced thermoplastic

**AGENCY LISTINGS**

Tested to UL778 CAN 22.2 by  
CSA International (Canadian Standards Association)

**xylem**  
Let's Solve Water

Xylem Inc.  
2881 East Bayard Street Ext., Suite A  
Seneca Falls, NY 13148  
Phone: (866) 325-4210 • Fax: (888) 322-5877  
www.xylem.com/goulds

Goulds is a registered trademark of Goulds Pumps, Inc. and is used under license.  
© 2021 Xylem Inc. GFESERSALES R2 July 2021

Order Online: [www.PumpCatalog.com](http://www.PumpCatalog.com)