

TECHNICAL BROCHURE

B3887BHF R4



WS_BHF Series

Model 3887BHF

SUBMERSIBLE SEWAGE PUMP



FEATURES

Impeller: Cast iron, enclosed, non-clog, dynamically balanced with pump out vanes for mechanical seal protection.

Casing: Cast iron flanged volute type for maximum efficiency. Designed for easy installation on A10-20 slide rail or base elbow rail systems.

Mechanical Seal: SILICON CARBIDE VS. SILICON CARBIDE sealing faces for superior abrasive resistance, stainless steel metal parts, BUNA-N elastomers.

Shaft: Corrosion-resistant, 300 series stainless steel. Threaded design. Locknut on all models to guard against component damage on accidental reverse rotation.

Fasteners: 300 series stainless steel.

Capable of running dry without damage to components.

Designed for continuous operation when fully submerged.

EXTENDED WARRANTY AVAILABLE FOR RESIDENTIAL APPLICATIONS.

APPLICATIONS

Specifically designed for the following uses:

- Homes
- Water transfer
- Sewage systems
- Light industrial
- Dewatering/Effluent
- Commercial applications

Anywhere waste or drainage must be disposed of quickly, quietly and efficiently.

SPECIFICATIONS

Pump

- Solids handling capabilities: 2" maximum
- Capacities: up to 220 GPM
- Total heads: up to 81 feet TDH
- Discharge size: 2" NPT threaded companion flange as standard. 3" option available but must be ordered separately. (Order no. A1-3)
- Temperature: 104°F (40°C) continuous
140°F (60°C) intermittent.

MOTORS

- Fully submerged in high grade turbine oil for lubrication and efficient heat transfer. All ratings are within the working limits of the motor.

Class B insulation on 1/3-1 1/2 HP models.

Class F insulation on 2 HP models.

Single phase (60 Hz):

- Capacitor start motors for maximum starting torque.
- Built-in overload with automatic reset.
- SJTOW or STOW severe duty oil and water resistant power cords.
- 1/3 - 1 HP models have NEMA three prong grounding plugs.
- 1 1/2 HP and larger units have bare lead cord ends.

Three phase (60 Hz):

- Class 10 overload protection must be provided in separately ordered starter unit.
- STOW power cords all have bare lead cord ends.
- Bearings: Upper and lower heavy duty ball bearing construction.
- Designed for Continuous Operation: Pump ratings are within the motor manufacturer's recommended working limits, can be operated continuously without damage when fully submerged.
- Power Cable: Severe duty rated, oil and water resistant. Epoxy seal on motor end provides secondary moisture barrier in case of outer jacket damage and to prevent oil wicking. Standard cord is 20'. Optional lengths are available.
- Motor Cover O-ring: Assures positive sealing against contaminants and oil leakage.

AGENCY LISTINGS



Tested to UL 778 and CSA 22.2 108 Standards
By Canadian Standards Association
File #LR38549

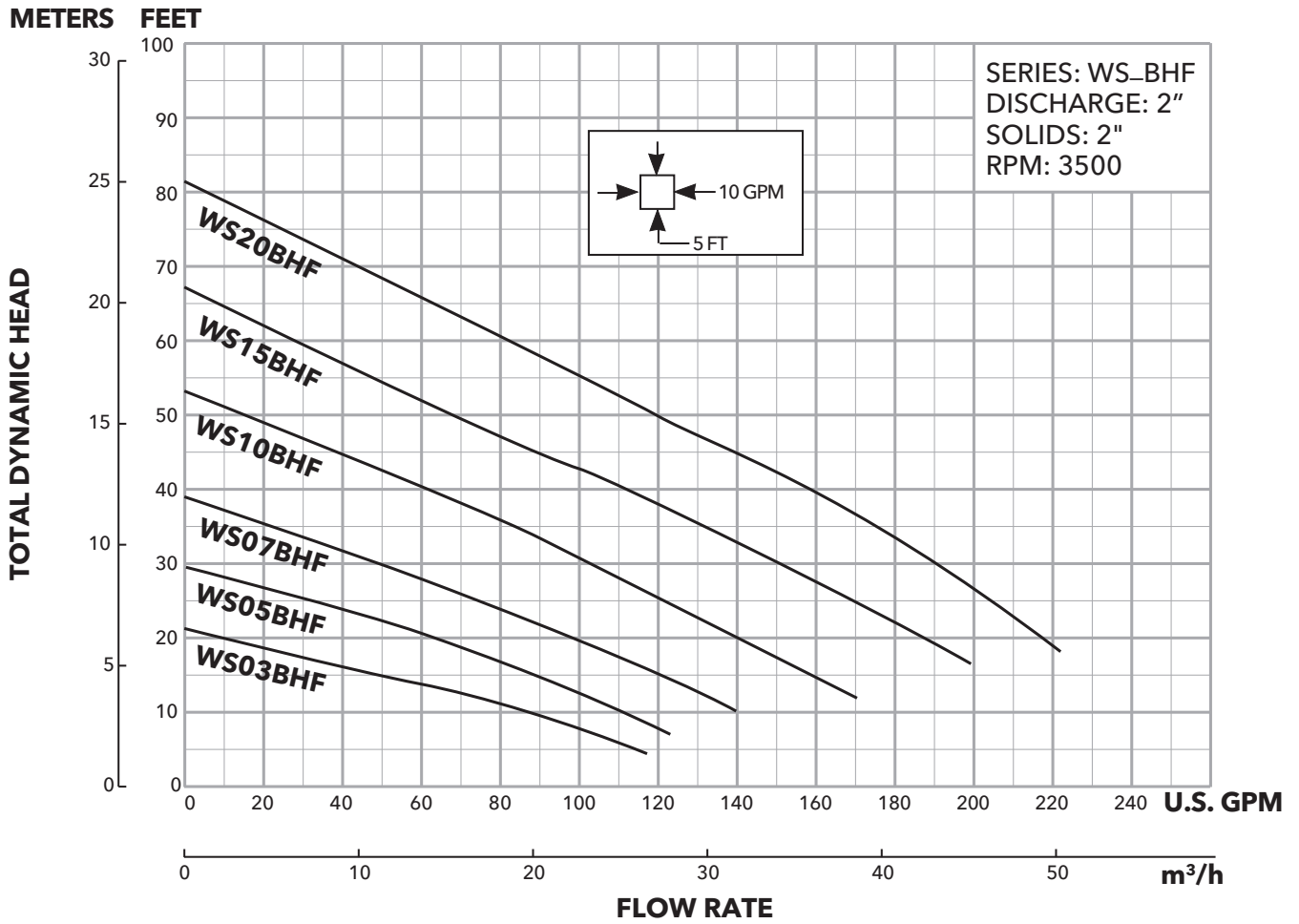

DIMENSIONS

(All dimensions are in inches. Do not use for construction purposes.)

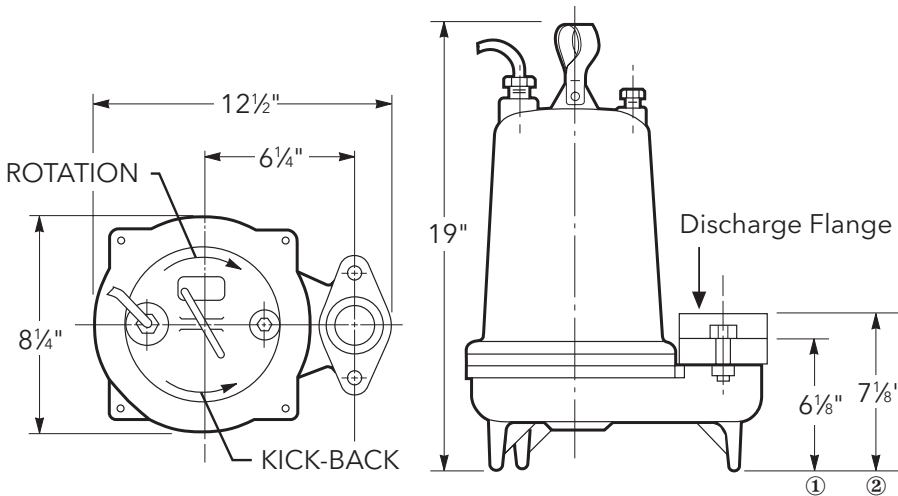

MOTOR AND MODEL INFORMATION

Order Number	HP	Phase	Volts	RPM	Impeller Diameter (in.)	Maximum Amps	Locked Rotor Amps	KVA Code	Full Load Motor Efficiency %	Resistance		
										Start	Line-Line	
WS0311BHF	0.33	1	115	3500	2.94	12.4	46.0	M	54	7.5	1.0	
WS0318BHF			208			6.8	31.0	K	68	9.7	2.4	
WS0312BHF			230			6.2	34.5	M	53	9.6	4.0	
WS0511BHF	0.5	1	115		3.19	14.5	46.0	M	54	7.5	1.0	
WS0518BHF			208			8.4	31.0	K	68	9.7	2.4	
WS0512BHF			230			7.6	34.5	M	53	9.6	4.0	
WS0538BHF	3	3	200			4.9	22.6	R	68	-	3.8	
WS0532BHF			230			3.6	18.8	R	70	-	5.8	
WS0534BHF			460			1.8	9.4	R	70	-	23.2	
WS0537BHF			575			1.5	7.5	R	62	-	35.3	
WS0718BHF	0.75	1	208			3.44	11.0	31.0	K	68	9.7	2.4
WS0712BHF			230				10.0	27.5	J	65	12.2	2.7
WS0738BHF		3	3		200		6.2	20.6	L	64	-	5.7
WS0732BHF					230		5.4	15.7	K	68	-	8.6
WS0734BHF					460		2.7	7.9	K	68	-	11
WS0737BHF					575		2.2	9.9	L	78	-	26.5
WS1018BHF	1	1	208		3.75	14.5	59.0	K	68	9.3	1.1	
WS1012BHF			230			13.0	36.2	J	69	10.3	2.1	
WS1038BHF		3	3	200		8.6	27.6	M	77	-	2.7	
WS1032BHF				230		7.5	24.1	L	79	-	4.1	
WS1034BHF				460		3.8	12.1	L	79	-	16.2	
WS1037BHF				575		3.1	9.9	L	78	-	26.5	
WS1512BHF	1.5	3	230	4.00	18.0	52.0	J	67	2.76	0.53		
WS1538BHF			200		10.0	42.4	K	78	-	1.7		
WS1532BHF			230		9.6	42.4	K	78	-	1.7		
WS1534BHF			460		4.8	21.2	K	78	-	6.6		
WS1537BHF			575		3.9	16.3	L	78	-	10.5		
WS2012BHF	2	3	230	4.44	18.0	49.6	F	78	3.2	1.1		
WS2038BHF			200		12.0	42.4	K	78	-	1.7		
WS2032BHF			230		11.6	42.4	K	78	-	1.7		
WS2034BHF			460		5.8	21.2	K	78	-	6.6		
WS2037BHF			575		4.7	16.3	L	78	-	10.5		

PERFORMANCE RATINGS (gallons per minute)

Order No.	WS03-BHF	WS05-BHF	WS07-BHF	WS10-BHF	WS15-BHF	WS20-BHF	
Total Head Feet of Water	HP	½	½	¾	1	1½	2
	RPM	3500	3500	3500	3500	3500	3500
	10	86	110	140	-	-	-
	15	48	88	120	158	-	-
	20	-	62	98	139	186	217
	25	-	32	74	120	170	204
	30	-	-	49	101	150	190
	35	-	-	21	82	130	175
	40	-	-	-	60	110	159
	45	-	-	-	38	88	140
	50	-	-	-	-	67	120
	55	-	-	-	-	47	100
	60	-	-	-	-	29	80
	65	-	-	-	-	-	62
	70	-	-	-	-	-	43
	75	-	-	-	-	-	23

COMPONENTS (for reference only)

Item No.	Description
1	Impeller
2	Casing
3	Mechanical Seal
4	Motor Shaft
5	Motor
6	Ball Bearings
7	Power Cable
8	Casing O-Ring

* For repair parts, reference repair parts book.

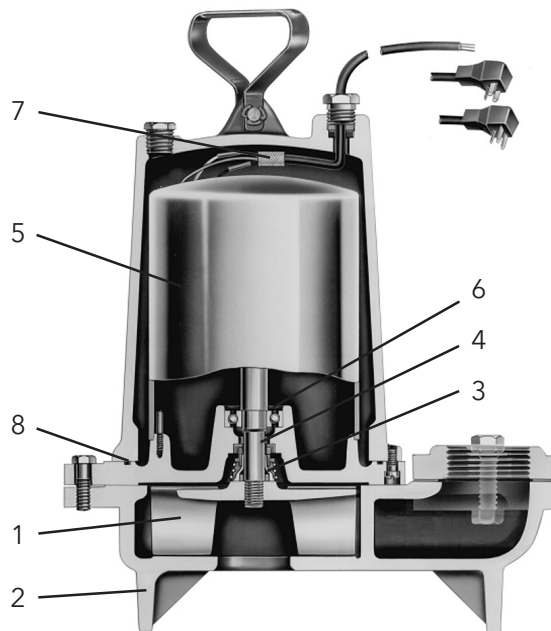

STANDARD PANEL OPTIONS

Pump Order Number	K Series		Boulay Series	
	Simplex	Duplex	Simplex	Duplex
WS0311BHF	KS19020WF	KD19020WF	S10020	D10020
WS0318BHF	KS19020WF	KD19020WF	S10020	D10020
WS0312BHF	KS19020WF	KD19020WF	S10020	D10020
WS0511BHF	KS19020WF	KD19020WF	S10020	D10020
WS0518BHF	KS19020WF	KD19020WF	S10020	D10020
WS0512BHF	KS19020WF	KD19020WF	S10020	D10020
WS0538BHF	KS34518WF	KD34518WF	S34063	D34063
WS0532BHF	KS31255WF	KD31255WF	S32540	D32540
WS0534BHF	KS31255WF	KD31255WF	S31625	D31625
WS0537BHF	N/A	N/A	S31625	D31625
WS0718BHF	KS19020WF	KD19020WF	S10020	D10020
WS0712BHF	KS19020WF	KD19020WF	S10020	D10020
WS0738BHF	KS34518WF	KD34518WF	S34063	D34063
WS0732BHF	KS34518WF	KD34518WF	S34063	D34063
WS0734BHF	KS31255WF	KD31255WF	S32540	D32540
WS0734BHF	KS31255WF	KD31255WF	S31625	D31625
WS1018BHF	KS19020WF	KD19020WF	S10020	D10020
WS1012BHF	KS19020WF	KD19020WF	S10020	D10020
WS1038BHF	KS34518WF	KD34518WF	S36310	D36310
WS1032BHF	KS34518WF	KD34518WF	S36310	D36310
WS1034BHF	KS31255WF	KD31255WF	S32540	D32540
WS1037BHF	N/A	N/A	S32540	D32540
WS1512BHF	KS19020WF	KD19020WF	S10020	D10020
WS1538BHF	KS34518WF	KD34518WF	S31016	D31016
WS1532BHF	KS34518WF	KD34518WF	S36310	D36310
WS1534BHF	KS31255WF	KD31255WF	S34063	D34063
WS1537BHF	N/A	N/A	S32540	D32540
WS2012BHF	KS19020WF	KD19020WF	S10020	D10020
WS2038BHF	KS34518WF	KD34518WF	S31016	D31016
WS2032BHF	KS34518WF	KD34518WF	S31016	D31016
WS2034BHF	KS34518WF	KD34518WF	S34063	D34063
WS2037BHF	N/A	N/A	S34063	D34063

Note: Boulay Series part numbers have additional available features, see page 7 for more information.

Note: K Series panel part numbers include floats, to order without float switches, remove the 'WF' suffix. Boulay Series panels do not include float switches.



K-SERIES

- NEMA 4X dead front outdoor rated enclosure
- Red LED alarm beacon
- HOA selector switch
- Field wiring terminal block
- Single phase models handle 120, 208 and 230V service
- Three phase models handle 200, 230 and 460V service
- Requires separate control/alarm power feed
- See brochure "BCPKSDPANELS" for additional information

BOULAY SERIES

- NEMA 4X outdoor rated enclosure
- Red alarm beacon
- HOA selector switch
- Through door pump run light(s)
- Through door alarm test and horn silence button
- Single phase models handle 120, 208 and 230V service
- Three phase models handle 200, 230, 460 and 575V service
- Accepts single or dual power feed
- See brochure "BCP3 R11" for additional information on simplex models
- See brochure "BCP4 R14" for additional information on duplex models

Xylem |'zīləm|

- 1) The tissue in plants that brings water upward from the roots;
- 2) a leading global water technology company.

We're a global team unified in a common purpose: creating advanced technology solutions to the world's water challenges. Developing new technologies that will improve the way water is used, conserved, and re-used in the future is central to our work. Our products and services move, treat, analyze, monitor and return water to the environment, in public utility, industrial, residential and commercial building services settings. Xylem also provides a leading portfolio of smart metering, network technologies and advanced analytics solutions for water, electric and gas utilities. In more than 150 countries, we have strong, long-standing relationships with customers who know us for our powerful combination of leading product brands and applications expertise with a strong focus on developing comprehensive, sustainable solutions.

For more information on how Xylem can help you, go to www.xylem.com

Order Online: www.PumpCatalog.com



Xylem Inc.
2881 East Bayard Street Ext., Suite A
Seneca Falls, NY 13148
Phone: (866) 325-4210
Fax: (888) 322-5877
www.xylem.com/goulds

Goulds is a registered trademark of Goulds Pumps, Inc. and is used under license.
© 2019 Xylem Inc. B3887BHF R4 June 2019