

Please read and save this Repair Parts Manual. Read this manual and the General Operating Instructions carefully before attempting to assemble, install, operate or maintain the product described. Protect yourself and others by observing all safety information. The Safety Instructions are contained in the General Operating Instructions. Failure to comply with the safety instructions accompanying this product could result in personal injury and/or property damage! Retain instructions for future reference. AMT reserves the right to discontinue any model or change specifications at any time without incurring any obligation.

©2014 American Machine & Tool Co., Inc. of PA, A Subsidiary of The Gorman-Rupp Company, All Rights Reserved.

Periodic maintenance and inspection is required on all pumps to ensure proper operation. Unit must be clear of debris and sediment. Inspect for leaks and loose bolts. Failure to do so voids warranty.

High Head Centrifugal Pumps

12-Volt DC Models



Refer to pump manual 1808-634-00 for General Operating and Safety Instructions.

DESCRIPTION

These pumps are non self-priming units designed for use where higher heads are needed to handle liquid transfer, heating and cooling applications, where no suction lift is required. All models feature high-efficiency closed impellers with 3450 RPM, 56J frame, 12 VDC motors. The discharge port on all models can be rotated in 90° increments to accommodate specific applications. Casing working pressure to 150 psi (1034 kPa). These are manual units, no controls are supplied. Check motor wiring before putting unit into operation (see motor nameplate for specific wiring diagrams). All units are for use with non-flammable, non-abrasive liquids compatible with pump component materials

CAST IRON UNITS

Pump construction is cast iron casing and adapter. Cast 316 stainless steel impeller. Buna N type 21 mechanical shaft seal with carbon and ceramic wear faces. O-ring casing seal. Handles liquids from 40° to 180° F (4° to 82° C).

BRONZE UNITS

Pump construction is cast bronze casing and adapter. Cast 316 stainless steel impeller. Viton type 21 mechanical shaft seal with carbon and ceramic wear faces. O-ring casing seal. Handles liquids from 40° to 200° F (4° to 93° C).

316 STAINLESS STEEL UNITS

Pump construction is cast 316 stainless steel casing, adapter, and impeller. Viton type 21 mechanical shaft seal with carbon and ceramic wear faces. O-ring casing seal. Handles liquids from 40° to 200° F (4° to 93° C).

General Safety Information for 12 Volt DC Power

1. When connecting power leads, follow this order:
 - a. Connect POSITIVE or PLUS(+) terminal on motor to supply lead first.
 - b. Connect NEGATIVE or MINUS(-) terminal last.
 - c. When DISCONNECTING – Disconnect NEGATIVE (-) first, then disconnect POSITIVE (+) lead from motor terminal.
2. When attaching line leads to motor or battery/power supply terminals, be sure that surrounding area is adequately ventilated to prevent an explosion or fire from explosive or flammable vapors that may be present

▲ WARNING

Batteries emit hydrogen gas which is explosive. Avoid smoking, sparks or open flame anywhere in vicinity of battery. Explosion from battery can cause blindness. Shield eyes when working near any battery.

Batteries contain sulfuric acid. In case of contact with eyes, skin or clothing, flush immediately with large amount of water, get medical attention.

3. When running leads, be sure wire gage is adequately sized and all electrical connections are properly insulated and enclosed.

▲ WARNING

Do not add acid or electrolyte to battery being used – add only water. Consult battery manufacturers for any additional safety instructions.

4. Motor must be located out of the weather with access to adequate ventilation for cooling. Motor is not waterproof!
5. All wiring should be performed by a qualified electrician.

Maintenance

▲ WARNING

Make certain that the unit is disconnected from the power source before attempting to service or remove any components!

SHAFT SEAL REPLACEMENT

Refer to Figures Nos. 2 and 3.

REMOVAL OF OLD SEAL

IMPORTANT: Always replace both seal seat (Ref. No. 5) and seal head (Ref. No. 6) to insure proper mating of components! Also, impeller seal (Ref. No. 9) should be replaced anytime impeller fastener (Ref. No. 10) has been removed.

1. Remove fasteners (Ref. No. 3) connecting casing (Ref. No. 12) to adapter (Ref. No. 4).

High Head Centrifugal Pumps 12-Volt DC Models

- Remove casing.

▲ CAUTION

Care should be taken not to pinch or “shave” casing seal (Ref. No. 11) between adapter and casing.

- Use a box and/or socket wrench to remove impeller fastener. Remove impeller seal and impeller (Ref.No. 8).

NOTE: Motor shaft must be held in place to remove impeller. Back of the motor either has slot in shaft (use large screwdriver to hold) or has 2 flats on motor shaft (use 7/16 open end wrench to hold). Impeller and impeller fastener unscrew CCW when looking at the front of pump.

IMPORTANT: Care should be taken to ensure that the same number and thickness of shim washers (ref. No. 7) are replaced behind the impeller as was removed. Shim washers are located directly behind impeller and become loose as impeller is removed.

- The seal head can now be pulled from shaft.
- Pry seal seat from adapter.

INSTALLATION OF NEW SEAL

▲ CAUTION

The precision lapped faces on mechanical seal are easily damaged. Handle your repair seal carefully. Do not touch polished seal faces.

IMPORTANT: Be sure that shaft shoulder does not damage polished face (see Figure No. 2).

- Thoroughly clean all surfaces of seal seat cavity in adapter.
- Using a clean cloth, wipe shaft and shaft sleeve and make certain that they are perfectly clean.
- Wet the rubber portion of new seal seat with a light coating of soapy water. While wearing clean gloves or using a clean light rag, press seal seat squarely into adapter recess. Use cardboard washer (usually supplied with new seal), place over polished surface and use a piece of pipe or dowel rod to press in firmly but gently. Avoid scratching polished face.
- Dispose of cardboard washer. Check again to see that polished face is free of dirt as well as all other foreign particles and that it has not been scratched or damaged.
- Wet the inside rubber portion of new seal head with a light coating of soapy water. Slide head onto motor shaft with sealing surface facing seal seat (see figure 2).

NOTE: A short “run-in” period may be necessary to provide completely leak-free operation.

- Screw impeller onto shaft. Use screwdriver slot at rear of motor shaft (opposite the threaded end) to tighten impeller.

NOTE: It may be necessary to remove plug in motor end cap to expose slot. If removed, be sure to reinstall plug AFTER pump is completely assembled.

- Check if shaft turns freely by spinning impeller. If rubbing or binding is found, remove impeller and add a shim to shaft, then recheck. Repeat procedure until all rubbing is eliminated.
- Slide impeller seal onto exposed shaft. Screw acorn nut onto shaft and tighten.

- Place casing seal on adapter mounting flange. Attach casing using bolts being careful not to pinch or “shave” casing seal. As casing is being tightened, periodically spin impeller to check for interference with casing.

▲ CAUTION

Seal will produce minor drag when spinning motor shaft, but rubbing anywhere else must be eliminated! Otherwise, damage to pump and or motor may occur.

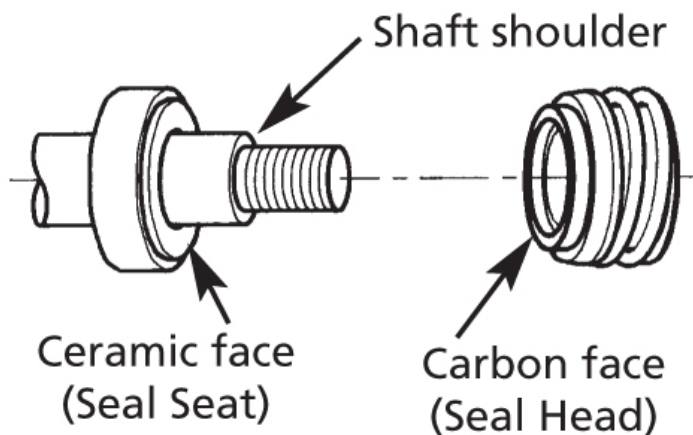

Figure 2 - Seal Installation

High Head Centrifugal Pumps 12-Volt DC Models

For Repair Parts contact dealer where pump was purchased.

Please provide following information:

-Model Number

-Serial Number (if any)

Part description and number as shown in parts list

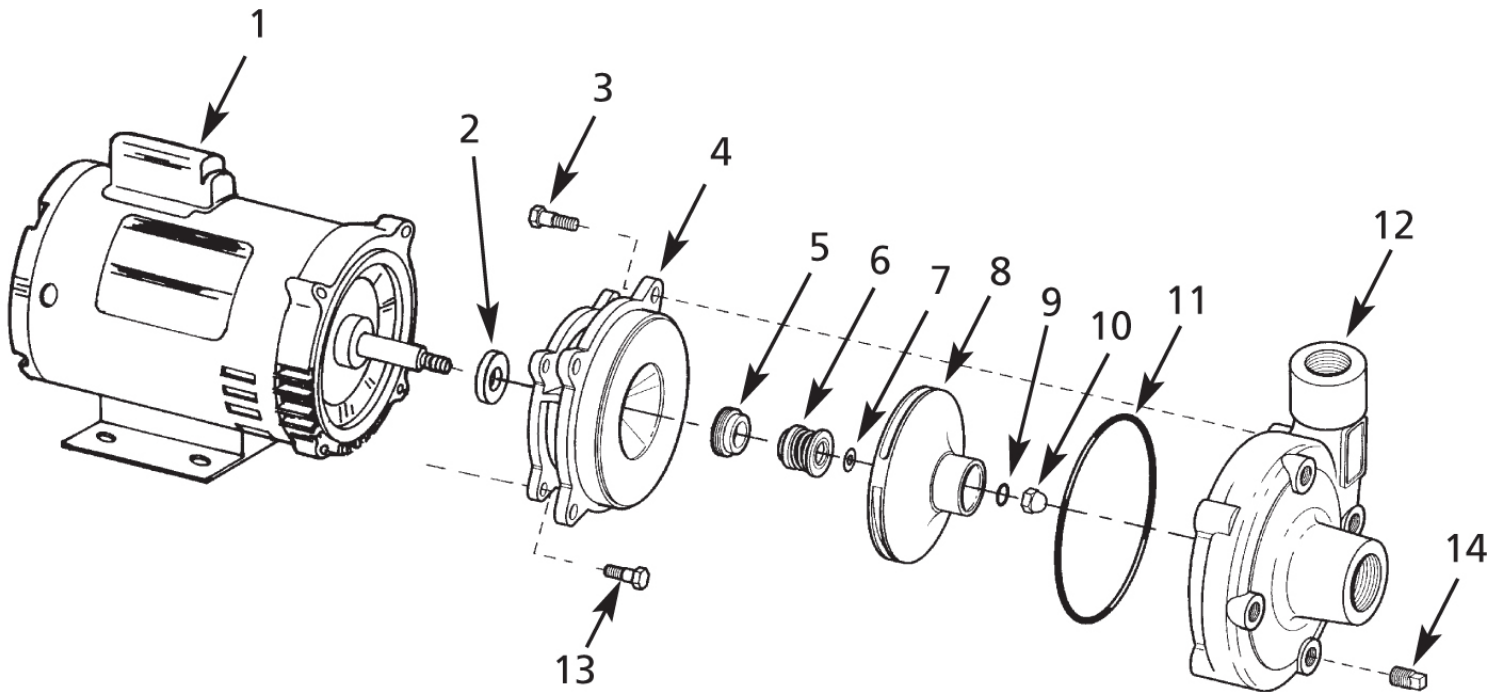

Figure 2 - Repair Parts Illustrations

Repair Parts List

Ref No.	Description	Part Number for Model	
		489G	Qty
1	Motor	1626-103-00	1
2	Slinger washer	1534-000-00	1
3	Fastener	Incl. w/ Ref 12	4
4	Adapter Kit - Cast Iron	4890-030-95	1
	Adapter Kit - Bronze	4890-030-97	1
	Adapter Kit - Stainless Steel	4890-030-98	1
	(includes Ref. Nos. 4 and 13)		
5 & 6	Shaft Seal Assembly - Buna-N	1640-161-96	1
	Shaft Seal Assembly - Viton	1640-161-97	1
7	Shim Kit	1806-044-90	1
8	Impeller	4896-011-01	1
9	Impeller Seal	Incl. w/ Ref. KIT	1
10	Impeller fastener	1784-001-00	1
11	Casing seal	Incl. w/ Ref Kit	1
12	Casing Kit - Cast Iron	4890-001-95	1
	Casing Kit - Bronze	4890-001-97	1
	Casing Kit - Stainless Steel	4890-001-98	1
	(includes Ref. Nos. 3, 12 and 14)		
13	Fastener	Incl. w/ Ref 4	4
14	3/8" NPT pipe plug	Incl.w/ Ref 12	4
KIT	O-Ring Kit - Buna-N	4890-300-90	1
	O-Ring Kit - Viton	4890-301-90	1
	(includes Ref. Nos. 9 and 11)		

(*) Standard hardware item, available locally.



American Machine & Tool Co., Inc. of PA
(herein "AMT")
400 Spring Street
Royersford, PA 19468
Phone: (610) 948-3800
Fax: (610) 948-5300
www.amtpump.com



General Information

SALES POLICY: AMT products are sold through our established Distributors. We do not sell direct to the consumer or organization not entitled to trade recognition. Therefore, possession of our catalogs and/or price list(s) does not infer an offer to sell.

MINIMUM ORDER: We appreciate your order, however, all orders are subject to a minimum \$35.00 net invoice charge (excluding freight). This applies to all pump and parts purchase orders.

PRICES: Prices are subject to change without notice. All orders accepted are subject to prices in effect at time of shipment.

PAYMENT TERMS: Terms, upon establishment of credit, are Net 30 days. Past due accounts may be subject to a service charge of 1.5% per month. Domestic or assignable letter of credit is required for all export trade.

PAST DUE ACCOUNTS: AMT reserves the right to withhold open account shipments on any past due account. Invoices are considered past due after thirty (30) days. In the interest of sound business, all orders are subject to approval of the Credit Department.

SHIPPING INSTRUCTIONS: All shipments will be made F.O.B. the factory. Where instructions for shipment do not appear on the order, the shipment will be made according to our best judgment. Full risk of loss (including transportation delays and losses) shall pass to the customer upon delivery of the products to the carrier at the F.O.B. point. When loss or delay occurs, primary responsibility for tracing rests with the customer. When there is LOSS or APPARENT VISIBLE DAMAGE to a shipment, when tendered for delivery, *DO NOT* give the carrier a clear receipt. Note such damage on the carrier's delivery receipt and *HAVE THE DRIVER SIGN THE RECEIPT.*

PRODUCT REVISIONS: AMT reserves the right to discontinue, change or improve its products or any portions thereof without being obligated to provide such a change or improvement for units sold and/or shipped prior to such a change or improvement.

LEAD TIME: Products designated "Quick Ship Product", also referred to as "QSP" will normally be shipped within 24 hours of receipt of a non-cancellable purchase order. Only limited quantities of "QSP" pumps are available.

STANDARD LEAD TIME: Lead time is two weeks for all non "QSP" product. AMT reserves the right to revise lead times as required due to availability of materials and all other causes beyond our control.

VIP SHIPMENT: Select AMT and IPT branded pumps are available for next day shipment for non-QSP (Quick Ship Products) items and subjected to a specific model surcharge per unit noted in the respective price book. Requires calling for availability, confirmation and a non-cancellable purchase order or credit card payment prior to shipment. The expedited shipping charges are an additional cost added separately from the VIP charges per item. AMT reserves the right to revise lead times as required due to availability of materials and all other causes beyond our control. QSP quantities are limited as determined by AMT.

ALL purchase orders must be submitted via hard copy sent to AMT customer service department by fax, EDI or e-mail.

RETURN GOODS POLICY: Goods shall not be returned without a return goods authorization number (RGA) issued by AMT customer service. The RGA number must be listed on the packing list. Only current model and part numbers with a valid date code may be returned (within one year from date of purchase). **A 20% restocking and packaging charge will apply to all returns. All shipping charges must be pre-paid. No exceptions.**

ORDER CHANGES BY CUSTOMER: Orders in process may not be changed except with written consent and may be subject to special charges.

12 Month Limited Warranty

EXTENT AND DURATION OF LIMITED WARRANTY

Coverage: American Machine & Tool Company (herein "AMT") or IPT Pumps by Gorman-Rupp (herein "IPT") or Gorman-Rupp Industries Division of The Gorman-Rupp Company, Patterson, or the Gorman-Rupp Company (herein referred to as "G-R Unit") each individually warrants that its products and parts shall be free from defects in material and workmanship for twelve (12) months from the date of purchase by the original end user when installation is made and maintenance is performed in accordance with G-R Unit's recommendations. Wear and tear resulting from use and items normally consumed in use are not covered.

EXCEPTIONS

(A) This Limited Warranty shall not apply to mechanical seals in AMT or IPT pumps and the following products and parts: engines, motors, trade accessories and all other products, components, parts and materials not manufactured by the G-R Units. These items may, however, be covered by the warranties of their respective manufacturers. (B) This warranty does not extend to or apply to any unit which has been repaired or altered at any place other than by a G-R Unit, or by persons not expressly approved by a G-R Unit to make repairs or alterations, nor to any unit the serial number, model number or identification of which has been removed, defaced or altered. (C) This warranty does not extend to any product manufactured by a G-R Unit, which has been subjected to mis-use, neglect, accident, improper installation, or use in violation of instructions furnished by a G-R Unit. (D) Pump Kits: This warranty does not extend to any product sold by a G-R Unit unassembled as a Pump Kit. Pump Kits are warranted against defects in material and workmanship for 60 days from the date of shipment from a G-R Unit. Any Pump Kit parts deemed defective by a G-R Unit will be replaced free of charge within 60 days of shipment. Pump Kits are not returnable for credit.

LIMITATIONS

THE G-R UNITS' SOLE AND EXCLUSIVE WARRANTY WITH RESPECT TO THEIR PRODUCTS AND PARTS IS THIS LIMITED WARRANTY. THIS LIMITED WARRANTY IS IN LIEU OF ALL OTHER EXPRESS AND/OR IMPLIED WARRANTIES, INCLUDING IMPLIED WARRANTIES OF MERCHANTABILITY AND FITNESS FOR PARTICULAR PURPOSE.

EXCLUSIVE REMEDY AND DAMAGES

The sole and exclusive remedy for breach of this Warranty by a G-R Unit and the entire extent of its liability for such breach or for damages arising from the use of the products and parts covered under this Limited Warranty, shall be as follows:

- Repair or Replacement:** If inspection shows that any G-R Unit product or part covered under this Limited Warranty is defective in materials or workmanship, the G-R Unit shall repair or replace the defective or non-conforming product or part without charge, whichever the G-R Unit chooses. You must have properly maintained and used the product or part claimed to be defective in accordance with the maintenance schedule or manual, which comes with the product. No allowance will be made for labor, installation, removal, transportation or other charges incurred by you in connection with such repair or replacement.
- To obtain the above remedy:
 - Immediately notify the G-R Unit upon discovery of the claimed defect in materials or workmanship and provide the serial number or date code of the product and/or part(s) or provide the G-R Unit with the invoice or bill of sale referencing the product by no later than the expiration date of the warranty period.
 - The G-R Unit will advise whether inspection will be necessary and how whether repair or replacement will be made. If inspection by the G-R Unit is necessary, the pump or defective part must be sent freight pre-paid to the G-R Unit. Return shipment will be F.O.B. the G-R Unit's plant.
 - Return Goods Authorization Requirement:** No product will be accepted for return or replacement without the prior written authorization of the G-R Unit. Upon such authorization, and in accordance with instructions from the G-R Unit, the product will be returned to the G-R Unit, shipping charges prepaid by the Buyer.
- Damages:** The G-R Unit's liability for damages for breach of this Limited Warranty shall not exceed the amount of the purchase price of the product or part(s) in respect to which Such damages are claimed. **IN NO EVENT SHALL THE G-R UNITS BE LIABLE FOR INCIDENTAL, CONSEQUENTIAL OR SPECIAL DAMAGES FOR BREACH OF THIS LIMITED WARRANTY.**

Some states do not allow the exclusion or limitation of incidental or consequential damages, so the above limitation or exclusion may not apply to you. This Limited Warranty gives you specific legal rights, and you may also have other rights, which vary from state to state.



A Gorman-Rupp Company



BY

GORMAN-RUPP®

www.amtpump.com