

SALES & ENGINEERING DATA

RATIO SERIES: **3.6:1**

FLUID P.S.I. RANGE: **180 - 4320**

650935-X43-C EXTRUSION PUMP

RELEASED: 9-24-01
REVISED: 5-26-10
REV. 05 S-1072

DIMENSIONAL DATA

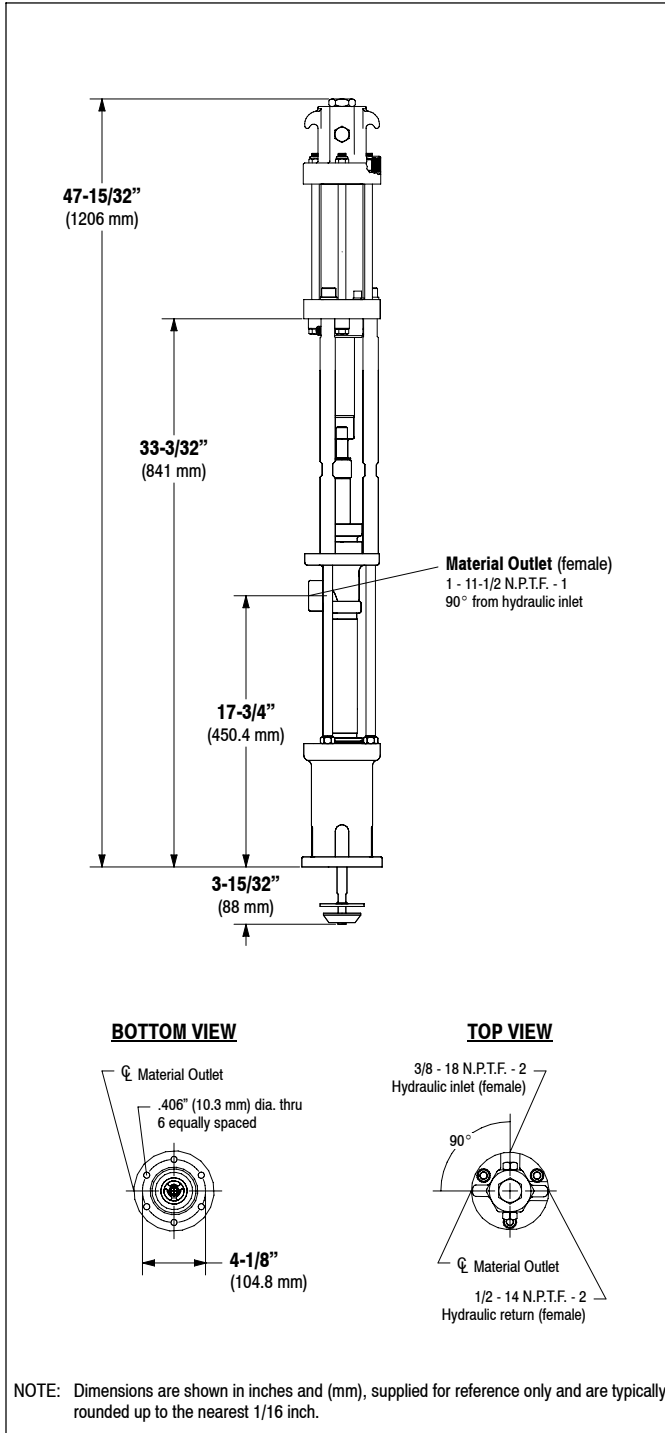

SPECIFICATIONS

CONSTRUCTION

Model Series (refer to option chart)	650935-X43-C
Pump Type	Hydraulically Operated, Extrusion, Double Acting Pump
Ratio	3.6:1
Hydraulic Motor	67147-B
Motor Repair Kit	637449
Motor Size	2.062 sq." (13.3 sq. cm)
Stroke	6" (15.2 cm)
Hydraulic Inlet (female)	3/8 - 18 N.P.T.F. - 2
Hydraulic Return (female)	1/2 - 14 N.P.T.F. - 2
Lower Pump End Series	66266-X43-B
Lower Pump Repair Kit	637074-X43-B

Packing Options:

3 - Glass filled PTFE
C - UHMW-PE
G - UHMW-PE / Leather staggered
P - UHMW-PE / Glass filled PTFE staggered upper • UHMW-PE lower
R - Glass filled PTFE / UHMW-PE staggered upper • Glass filled PTFE lower

Material Outlet (female) 1 - 11-1/2 N.P.T.F. - 1

MATERIALS OF CONSTRUCTION

Outlet Body	Ductile Iron, Nickel plated
Cylinder	Carbon Steel, Nickel plated
Plunger	17-4 SS, Chrome plated
Upper Check	440 Stainless Steel
Upper Seat	440 Stainless Steel
Lower Check	440 Stainless Steel
Lower Seat	440 Stainless Steel
Inlet Body	Ductile Iron, Nickel plated
Weight	62.1 lbs (28.2 kgs)

PERFORMANCE

Hydraulic Inlet Pressure Range	50 - 1200 p.s.i. (3.4 - 82.8 bar)
Fluid Pressure Range	180 - 4320 p.s.i. (12.4 - 297.9 bar)
Required H-power @ 50 c.p.m.	3.2 @ 1200 p.s.i. (82.8 bar)
Hydraulic flow required @ 50 c.p.m.	4.9 g.p.m. (18.5 l.p.m.)
Maximum rec'd Cycles / Minute	50
Displacement In ³ Per Cycle	6.959
Volume / Cycle	3.9 oz. (114.0 ml)
Cycles Per Gallon	33.2
Flow @ 50 Cycles / Minute	1.5 g.p.m. (5.7 l.p.m.)
Noise Level	N / A
Maximum Temperature Limit	130° F (54° C)

ACCESSORIES:

- 61937-1 Wall Bracket
- 65138 Floor Mounting Flange

PERFORMANCE CURVES

