

BALDOR® • ***RELIANCE***

Product Information Packet

D1151

.33HP,1750RPM,DC,56,3413D,TEFC,F1

Part Detail							
Revision:	T	Status:	PRD/A	Change #:		Proprietary:	No
Type:	DC	Prod. Type:		Elec. Spec:	34WG3115	CD Diagram:	CD0862B01
Enclosure:	TEFC	Mfg Plant:		Mech. Spec:	34-6121	Layout:	34LY6121
Frame:	56	Mounting:	F1	Poles:	2///	Created Date:	
Base:	RG	Rotation:	R	Insulation:	F	Eff. Date:	09-16-2016
Field Type:	Compound/stab Shunt	Literature:		Elec. Diagram:		Replaced By:	

Nameplate NP0111L			
CAT.NO.	D1151		
SPEC.	34-6121-3115		
HP	.33	ENCL	TEFC
RPM	1750		
FRAME	56	TYPE	3413D
ARM V	115	ARM A	3.2
FLD V		FLD A	
INSUL	F	AMB.	40
DUTY	CONT	SUPPLY	A
BRG/DE	6203	BRG/ODE	6203
BRUSHES	2/BP5000H03		
	IEEE 45	BLANK	
SER.			
BLANK	--		
APRV-CSA	<input type="checkbox"/>	APRV-UL	<input type="checkbox"/>

Parts List		
Part Number	Description	Quantity
SA006735	SA 34-6121-3115	1.000 EA
AA003369	AA 34-6121-3115	1.000 EA
BP5000H03SP	BRUSH ASSY, GRADE H619	1.000 EA
11XW1032G06	10-32 X .38, TAPTITE II, HEX WSHR SLTD U	1.000 EA
HW3001B01	BRASS CUP WASHER, FOR #8 SCREW	1.000 EA
34EP3103A06	FR ENDPLATE MACH 34DC F-1 MTG W/.50 N.P.	1.000 EA
WD4100A17	PLUG STIMPSON D4036	1.000 EA
HW5100A03SP	WAVY WASHER (W1543-017)	1.000 EA
34EP3110A06	PU ENDPLATE, MACH	1.000 EA
HA1005A05SP	SLINGER, OD 1.50, ID .659, 203 BRG	1.000 EA
BP5201A10SP	BRUSH HOLDER ASSY W/BP4509A01 & BP3000A0	1.000 EA
80XN1032A03	10-32 X 3/16 SET SCREW	2.000 EA
34FN3002A01SP	EXTERNAL FAN, PLASTIC, .637/.639 HUB W/	1.000 EA
34FH4002A03SP	IEC FH NO GREASER W/.88 DIA SHAFT HOLE,	1.000 EA
51XW1032A06	10-32 X .38, TAPTITE II, HEX WSHR SLTD S	3.000 EA
WD4100A81	CAPLUG BPF-7/8, FOR .86-.88 HOLE	1.000 EA
34CB4504SP	CONDUIT BOX LID, STAMPED	1.000 EA
34GS1014	GASKET,CONDUIT BOX LID BLACK NEOPRENE	1.000 EA
51XW0832A07	8-32 X .44, TAPTITE II, HEX WSHR SLTD SE	2.000 EA
HW2501D13	KEY, 3/16 SQ X 1.375	1.000 EA
HA7000A04	KEY RETAINER 0.625 DIA SHAFTS	1.000 EA
WD4102A07	STRAIN RELIEF - MICRO PLASTIC #23MP07W20	1.000 EA
MG1000G27	MED CHARCOAL METALLIC GREY 400-0096	0.014 GA
MJ5004A05	#242-21 LOCTITE GENERAL PURPOSE MED. STR	0.001 EA

Parts List (continued)		
Part Number	Description	Quantity
MJ5001A27	32220KN GRAY SEALER *MIN BUY 4 QTS=1GAL	0.001 QT
10XF0440S02	04-40 X 1/8 TYPE F HEX HD STAINLESS STIC	2.000 EA
HA3100A39	THRUBOLT 10-32 X 6.375	4.000 EA
LB1119N	WARNING LABEL	1.000 EA
LC0862	DC -- COMPOUND WOUND MOTOR CONNECTION LA	1.000 EA
MN416A01	TAG-INSTAL-MAINT no wire (1200/bx) 11/14	1.000 EA
NP0111L	NP STD LASER ENGRAVED DC MOTORS, UL CSA	1.000 EA
35PA1000	PKG GRP, PRINT PK1008A06	1.000 EA

DC Motor Performance Data

Record # 2017 - Typical performance - not guaranteed values

Winding: 34WG3115-R001	Type: 3413D	Enclosure: TEFC
-------------------------------	--------------------	------------------------

Nameplate Data		General Characteristics	
Rated Output (HP)	0.33	Armature Resistance @ 25°C	3.5351 Ω
R.P.M.	1750		
Armature Volts	115	Series Winding Resistance @ 25°C	1.0818 Ω
Armature Amps	2.9	Shunt Winding Resistance @ 25°C	339.14 Ω
Field Volts	115		
Field Amps	0.4	Armature Inertia	3.042 LI ²
Rating - Duty	40C AMB-CONT		
Power Supply Code	K		

Load Characteristics at 115 Armature Volts, 115 Field Volts, 0.36 Field Amps

Load Point	1	2	3	4	5	6	7
Armature Amps	0.45	1.8	2.4	3	3.7	4.5	5
R.P.M.	2200	1999	1924	1840	1760	1670	1580
Torque (LB-FT)	0	0.5	0.75	1	1.25	1.5	1.75

Performance Graph at 115.0 Arm V, 0.33HP Typical performance - Not guaranteed values

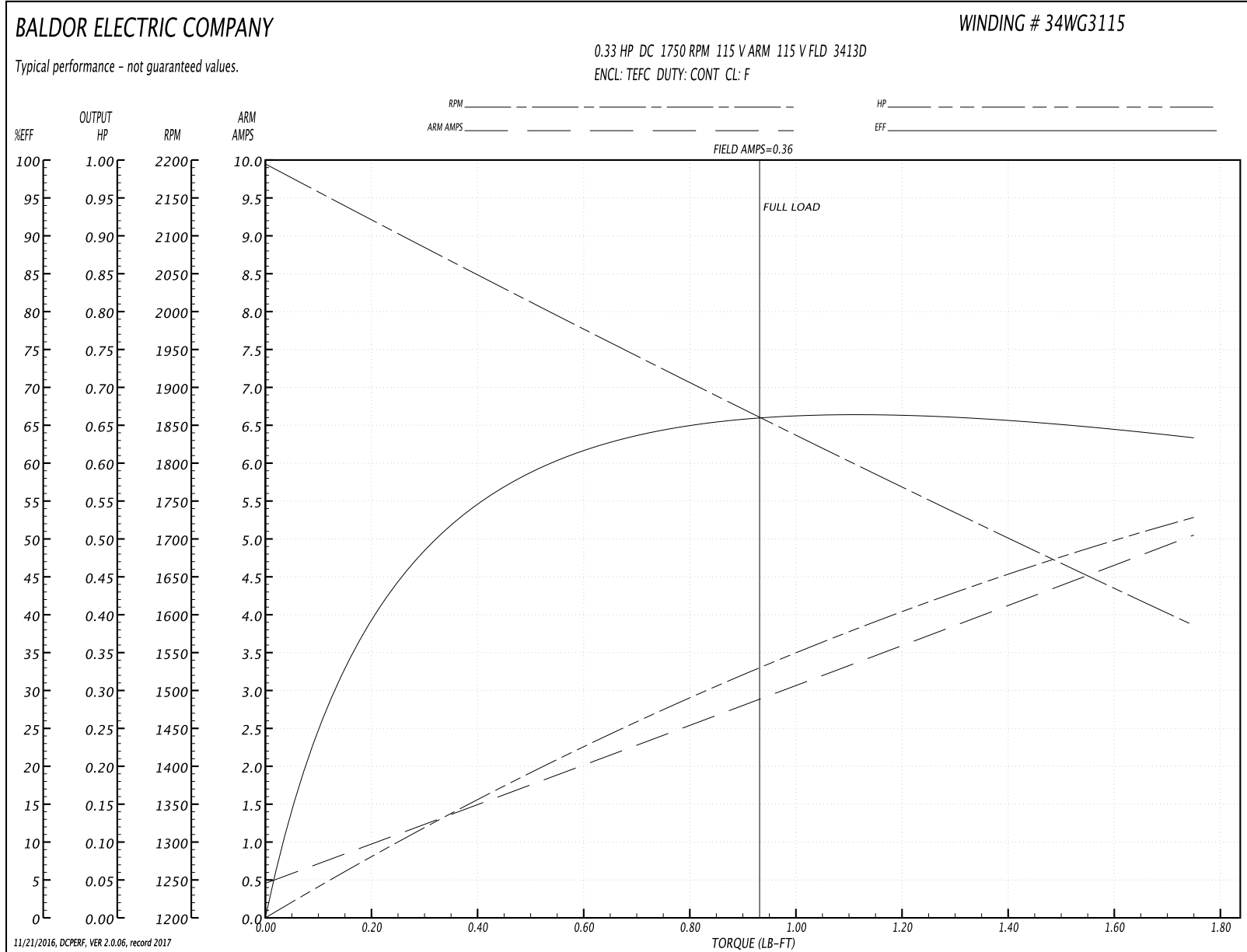

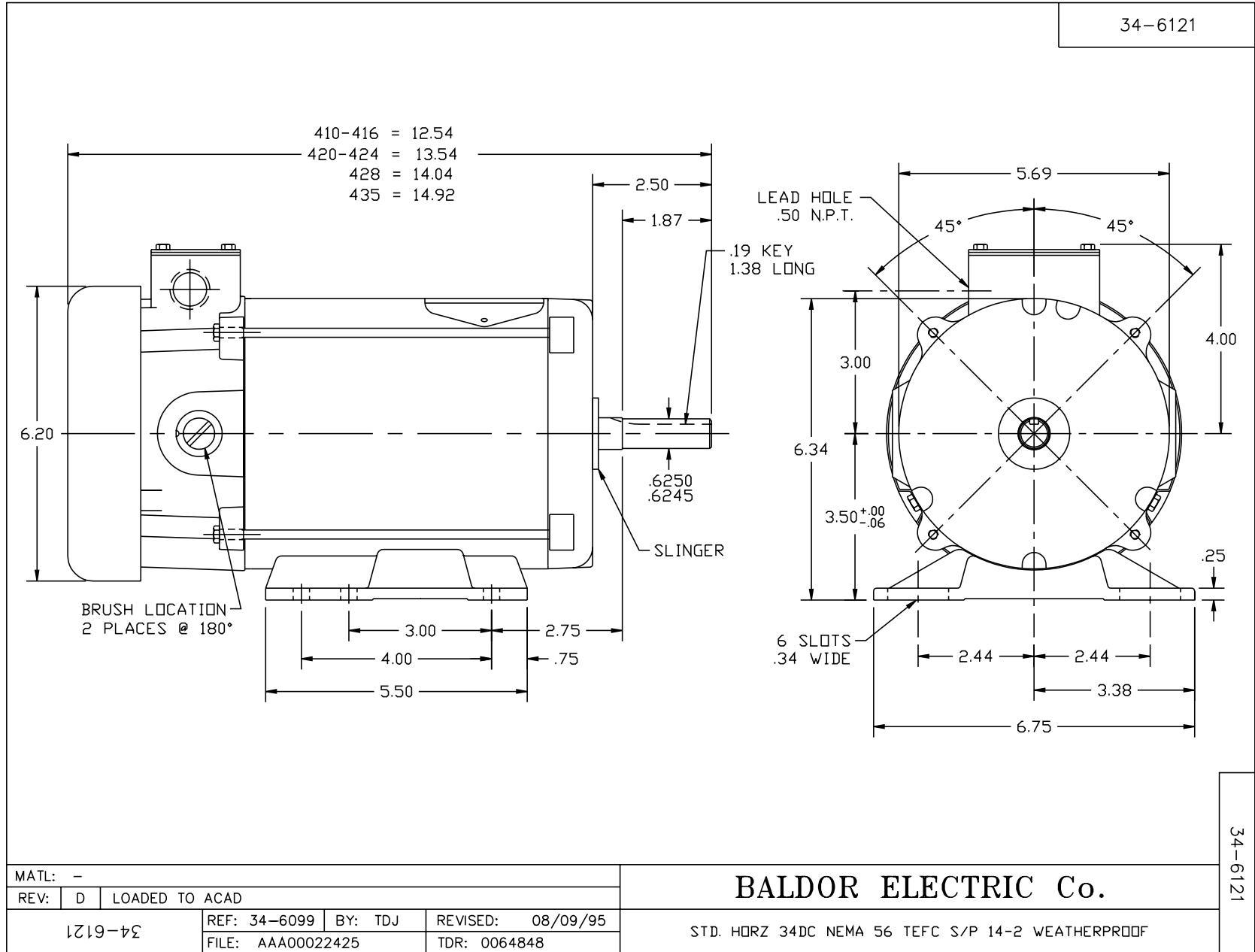

CD0862B01

COMPOUND WOUND

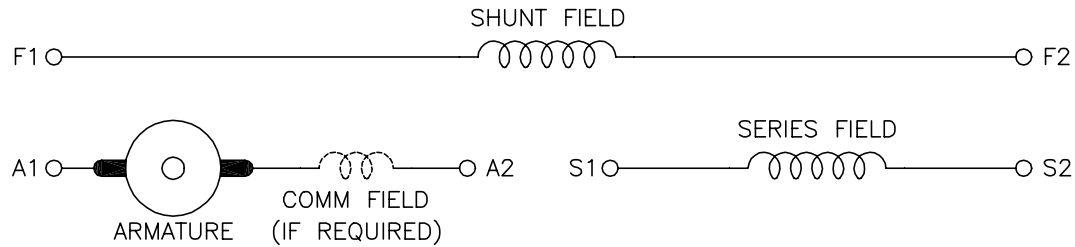

DIRECTION OF ROTATION				
CWDE		CCWDE		
POS TERM (+)	NEG TERM (-)	POS TERM (+)	NEG TERM (-)	
A1	S2	A2	S2	
F1	F2	F1	F2	
CONNECT A2 & S1		CONNECT A1 & S1		

NOTES:

1. LIMIT STARTING INRUSH CURRENT TO NOT MORE THAN 3 TIMES RATED AMPERES BY ENERGIZING THE FULL SHUNT FIELD BEFORE BRINGING THE ARMATURE VOLTAGE UP SLOWLY OR IN STEPS.
2. OPTIONAL FIELD REOSTAT MAY BE CONNECTED IN SERIES WITH THE SHUNT FIELD.
3. OPTIONAL THERMOSTAT LEADS ARE MARKED J,J.

REV. DESC: NEW, REPLACE CD0862

REV. LTR: - BY: JLP REVISED: 16:10:51 11/03/2004 TDR: 347796

10BZ98000
CD0862B01

FILE: AAA00121482 REF: CD0862B01
MTL: -

BALDOR ELECTRIC Co.

DC CONNECTION DIAGRAM, COMPOUND FIELD, 6 LEAD

CD0862B01