

BALDOR® • ***RELIANCE***

Product Information Packet

VSSWDM3534

.33HP,1755RPM,3PH,60HZ,56C,3512M,TENV,F1

Part Detail							
Revision:	E	Status:	PRD/A	Change #:		Proprietary:	No
Type:	AC	Prod. Type:	3512M	Elec. Spec:	35WGL029	CD Diagram:	CD0005
Enclosure:	TENV	Mfg Plant:		Mech. Spec:	35V824	Layout:	35LYV824
Frame:	56C	Mounting:	F1	Poles:	04	Created Date:	12-27-2013
Base:	N	Rotation:	R	Insulation:	F	Eff. Date:	11-04-2016
Leads:	9#18					Replaced By:	
Literature:		Elec. Diagram:					

Nameplate NP1951A01										
CAT.NO.	VSSWDM3534									
SPEC.	35V824L029G1									
HP	.33									
VOLTS	208-230/460									
AMP	1.3/.65									
RPM	1755									
FRAME	56C				HZ	60			PH	3
SER.F.	1.25		CODE	P	DES	B		CLASS	F	
NEMA-NOM-EFF	75.5			PF	61					
RATING	40C AMB-CONT									
CC	USABLE AT 208V									
DE	6205			ODE	6203					
ENCL	TENV	SN								
	SFA 1.4/.7									

Parts List		
Part Number	Description	Quantity
SA274242	SA 35V824L029G1	1.000 EA
RA260829	RA 35V824L029G1	1.000 EA
NS2512A01	INSULATOR, CONDUIT BOX X	1.000 EA
35CB5001A08	CONDUIT BOX KIT, S/P 9-2 (ALL STAINLESS)	1.000 EA
HA5027A02	HA4054 T-DRAIN X2 BAGGED WITH LABEL	1.000 EA
11XW1032G06	10-32 X .38, TAPTITE II, HEX WSHR SLTD U	1.000 EA
HW3001B01	BRASS CUP WASHER, FOR #8 SCREW	1.000 EA
35FE1913A01	FR ENDPLATE ASSY	1.000 EA
HW5100A03SP	WAVY WASHER (W1543-017)	1.000 EA
35PE1914A02	PU EP ASSY. FOR LOCKED BRG	1.000 EA
HW4606A02	JM CLIPPER/SEAL (LWE-0938-1624-AL23)	1.000 EA
12XN1032S22	10-32 X 1 3/8 SLOT HEX, STAINLESS STEEL	2.000 EA
HA1049A01	DUBO LOK WASHER SIZE 10 (NYLON LOCK SEAL	2.000 EA
HA1049A01	DUBO LOK WASHER SIZE 10 (NYLON LOCK SEAL	4.000 EA
HW2502D13	SS KEY, 3/16 SQ X 1.375	1.000 EA
HA7000A04	KEY RETAINER 0.625 DIA SHAFTS	1.000 EA
MJ5001A02	732 CL SEALANT 3 OZ DIXIE BEARING 289100	0.001 EA
MJ1000A02	GREASE, POLYREX EM EXXON (USe 4824-15A)	0.050 LB
HA3100S45	THRU BOLT HEX-HEAD 7.95 10-32	4.000 EA
MN416A01	TAG-INSTAL-MAINT no wire (1200/bx) 11/14	1.000 EA
35PA1066	PKG GRP, PRINT PK1008A06	1.000 EA
PK3082	STYROFOAM CRADLE	1.000 EA

AC Induction Motor Performance Data
Record # 44202 - Typical performance - not guaranteed values

Winding: 35WGL029-R001	Type: 3512M	Enclosure: TENV
-------------------------------	--------------------	------------------------

Nameplate Data				460 V, 60 Hz: High Voltage Connection	
Rated Output (HP)	.33			Full Load Torque	0.971 LB-FT
Volts	208-230/460			Start Configuration	direct on line
Full Load Amps	1.3/.65			Breakdown Torque	5.35 LB-FT
R.P.M.	1755			Pull-up Torque	3.65 LB-FT
Hz	60	Phase	3	Locked-rotor Torque	4.15 LB-FT
NEMA Design Code	B	KVA Code	P	Starting Current	5.24 A
Service Factor (S.F.)	1.25			No-load Current	0.51 A
NEMA Nom. Eff.	75.5	Power Factor	61	Line-line Res. @ 25°C	42.4 Ω
Rating - Duty	40C AMB-CONT			Temp. Rise @ Rated Load	42°C
S.F. Amps	1.4/.7			Temp. Rise @ S.F. Load	49°C
				Locked-rotor Power Factor	77
				Rotor inertia	0.0709 LB-FT ²

Load Characteristics 460 V, 60 Hz, 0.33 HP

% of Rated Load	25	50	75	100	125	150	S.F.
Power Factor	26	40	52	61	68	74	68
Efficiency	50.9	66.6	73.7	76.2	77.6	77.4	77.6
Speed	1791	1780	1769	1755	1740	1725	1740
Line amperes	0.52	0.54	0.59	0.65	0.71	0.8	0.71

Performance Graph at 460V, 60Hz, 0.33HP Typical performance - Not guaranteed values

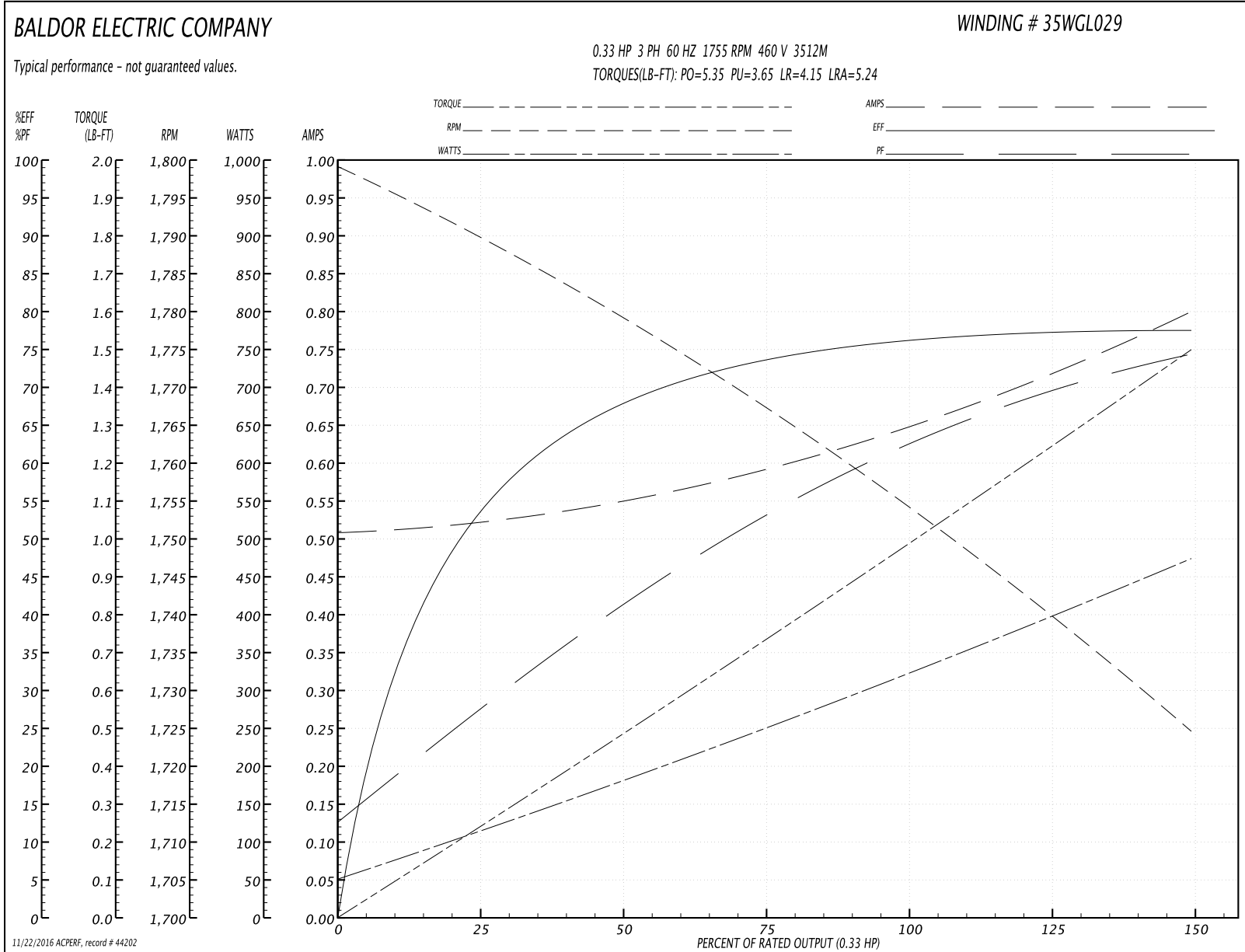

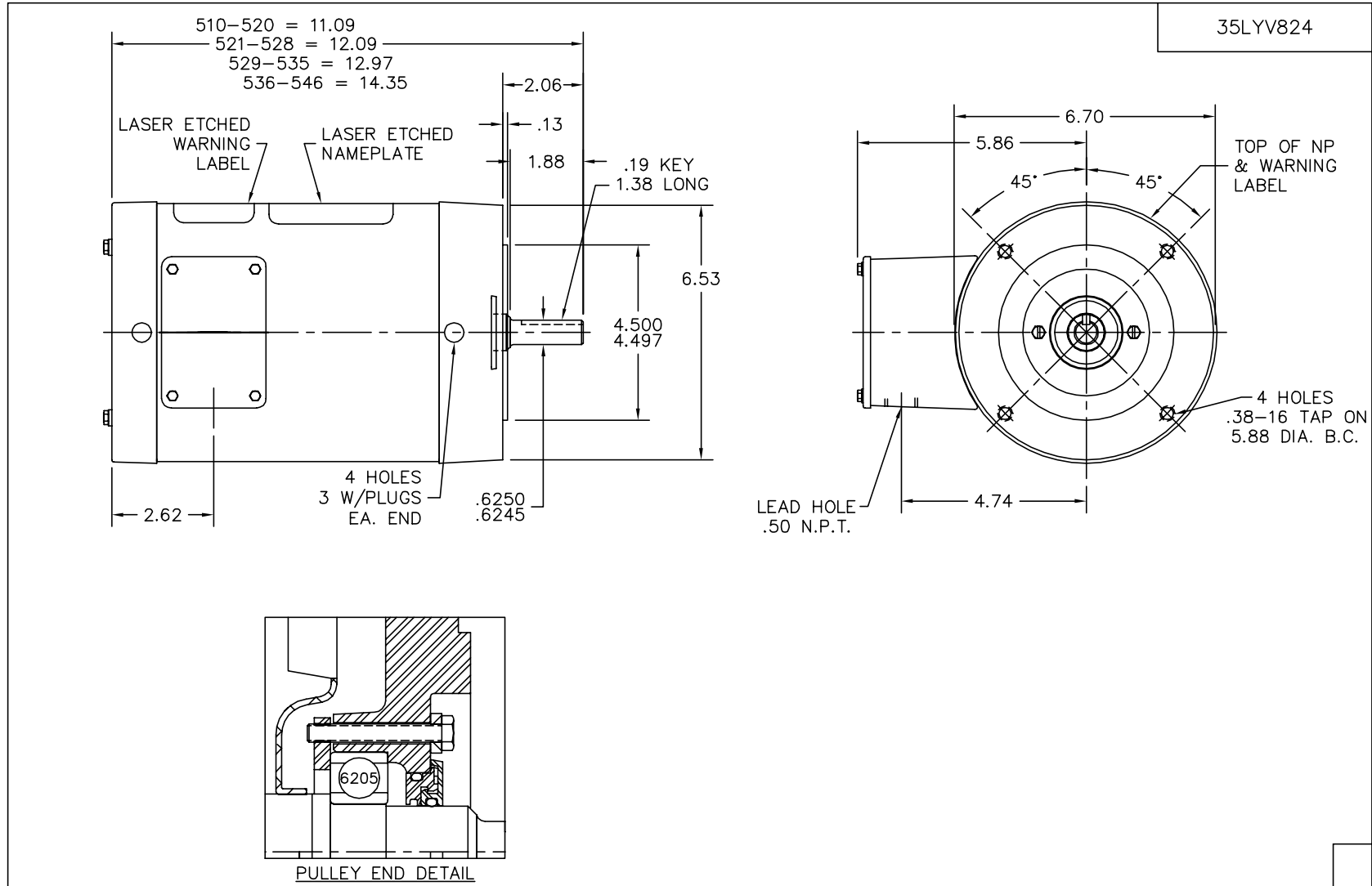

CUSTOMER IS RESPONSIBLE FOR DETERMINING THAT MOTOR PERFORMANCE IS SUITABLE IN THE APPLICATION.

REV. DESC: ADD KOBX LOCATION DIMENSION

REV. LTR: A	VERSION: 01	TDR: 000000450943
4Z8VY7G	FILE: \AAA\00137\898	REVISED: 06:24:20 12/07/2007
	MTL: -	BY: ENCHECO

Baldor • Dodge • Reliance

VERT 56C TENV 35M WD4 W/LOCKED PU BRG & LASER ETCHED BAND

35LYV824

CD0005



LOW VOLTAGE
(2Y)

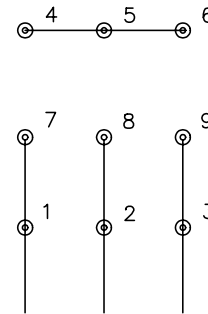

LINE

HIGH VOLTAGE
(1Y)

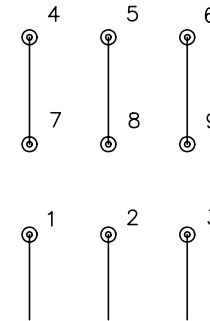

LINE

NOTES:

1. INTERCHANGE ANY TWO LINE LEADS TO REVERSE ROTATION.
2. OPTIONAL THERMOSTATS ARE PROVIDED WHEN SPECIFIED.
3. ACTUAL NUMBER OF INTERNAL PARALLEL CIRCUITS MAY BE A MULTIPLE OF THOSE SHOWN ABOVE.
4. LEAD COLORS ARE OPTIONAL. LEADS MUST ALWAYS BE NUMBERED AS SHOWN.

REV. DESC: REVISE TO SHOW OPTIONAL COLORS			
REV. LTR: E	BY: JLP	REVISED: 01/19/99 10:15	TDR: 0171435
90000		FILE: AAA00005140	MDL: -
		MTL: -	

BALDOR ELECTRIC Co.

3PH, DV, 9 LEADS

CD0005