

# **BALDOR**® • ***RELIANCE***

## **Product Information Packet**

# **CNL20172**

**.17HP,3450RPM,1PH,60HZ,2524C,TENV,F1**

Part Detail							
Revision:	M	Status:	PRD/A	Change #:		Proprietary:	No
Type:	AC	Prod. Type:	2524C	Elec. Spec:	25WGW005	CD Diagram:	CD1804
Enclosure:	TENV	Mfg Plant:		Mech. Spec:		Layout:	25E633W005
Frame:	42C	Mounting:	F1	Poles:	02	Created Date:	
Base:		Rotation:	R	Insulation:	F	Eff. Date:	10-20-2016
Leads:	4#18					Replaced By:	
Literature:		Elec. Diagram:					

Nameplate NP1416A02										
CAT.NO.	CNL20172				SER.NO					
SPEC.	25E633W005									
HP	.17 TE			VOLTS	115					
AMP	1.9				HZ	60				
PH	1	CAP	15		CODE	-	CLASS	F		
SER.F.	1.00		SF AMP							
RATED RPM	3450									
RATING	40C AMB-CONT				APRV-CSA	<input type="checkbox"/>		APRV-UL	<input type="checkbox"/>	

Parts List		
Part Number	Description	Quantity
SA123632	SA 25E633W005	1.000 EA
RA114113	RA 25E633W005	1.000 EA
OC4015A02	DRY FILM METALLIZED CAP,15MFD 250V	1.000 EA
LC0127	CONNECTION DIAGRAM	1.000 EA
25EP2300A04G	EP,25AC DE CL 6200 42C FOR EXT. HSG	1.000 EA
HW5002A45	RETAINING RING,WALDES TRUARC N5002-118	1.000 EA
25BA4000G	BASE,STAMPED	1.000 EA
11XN1032A08	10-32 X 1/2 HEX SLT WS HD X	4.000 EA
HW1004A10	WASHER,LOCK,#10 INT. TOOTH	4.000 EA
MJ5004A35	ADHESIVE LOCTITE #243-31 50 ML	0.001 EA
CB0100B01G	CB,EXR 25 .88 LEAD EXIT F1 POSITION	1.000 EA
GS0120	GASKET,CONDUIT BOX FOR CB2000A17	1.000 EA
15XN0832A08	SCREW PAN HD 08-32 X 1/2 (PHILLIPS)	2.000 EA
CB0103A00G	CB,LID FOR CB0100 W/GRAY POWDER COATING	1.000 EA
GS0121A01	GASKET, LID FOR CB0100B00	1.000 EA
15XM0832A06	SCREW, 8-32X .375, THREAD FORMING	4.000 EA
25EP2101A12G	EP,25AC ODE CL NONE W/ GREY POWDER COATI	1.000 EA
HW5109A08	WASHER, WAVE SPRING FOR 30MM BORE SMALLE	1.000 EA
51XT0832G05	SCREW,HEX HD 8-32 X 5/16 GRN.	1.000 EA
HA3170A31	THRUBOLT, FLAT HD. #8-32 THDS X 6.95 LNG	2.000 EA
NP1416A02	NP,AC STD AD NONE V CSA UL MOTOR ONLY	1.000 EA
LB1242	ADHESIVE PATCH 1.10 X 2.03 X .045 THICK	0.001 EA
CPA1000	PACKING GROUP STD. SINGLE	1.000 EA
MN416A01	TAG-INSTAL-MAINT no wire (1200/bx) 11/14	1.000 EA

No performance data has been  
assigned to this product.

25E633W005

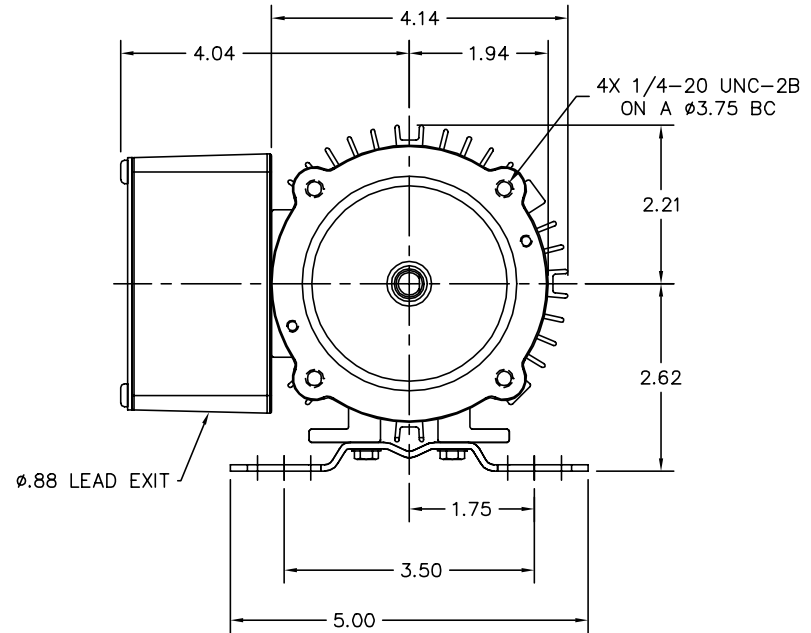
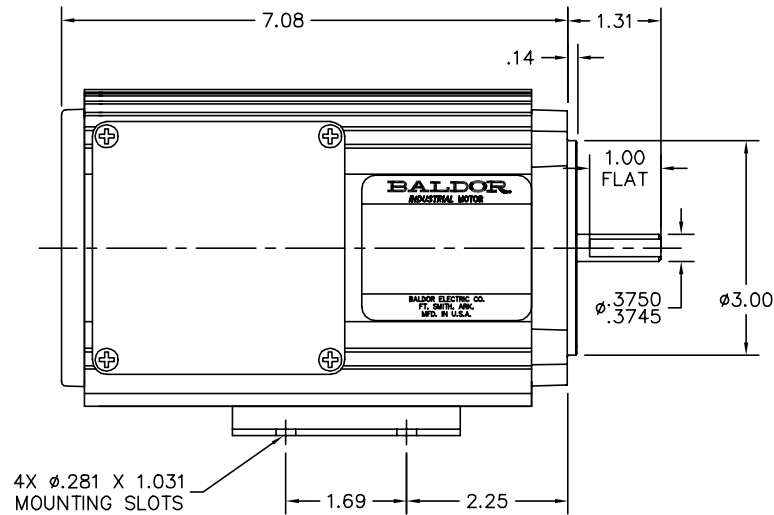

**NOTES:**

1. INSTALL BASE SCREWS WITH LOCTITE.
2. LABEL THE UNCONNECTED CAP LEAD WITH A #8 WIRE MARKER.
3. INSTALL CONNECTION LABEL UNDER CONDUIT BOX LID.

CUSTOMER IS RESPONSIBLE FOR DETERMINING THAT MOTOR PERFORMANCE IS SUITABLE IN THE APPLICATION.

REV. DESC: CORRECT THRU BOLT LOC		
REV. LTR: A	VERSION: 01	TDR: 000000387012
25E633W005	FILE: \CKA\00026\585	REVISED: 07:08:11 01/27/2006
	MTL: -	BY: CKRONSO

**BALDOR ELECTRIC Co.**

LY,25AC MTR EXR TENV W\BASE (25E068W005)

25E633W005

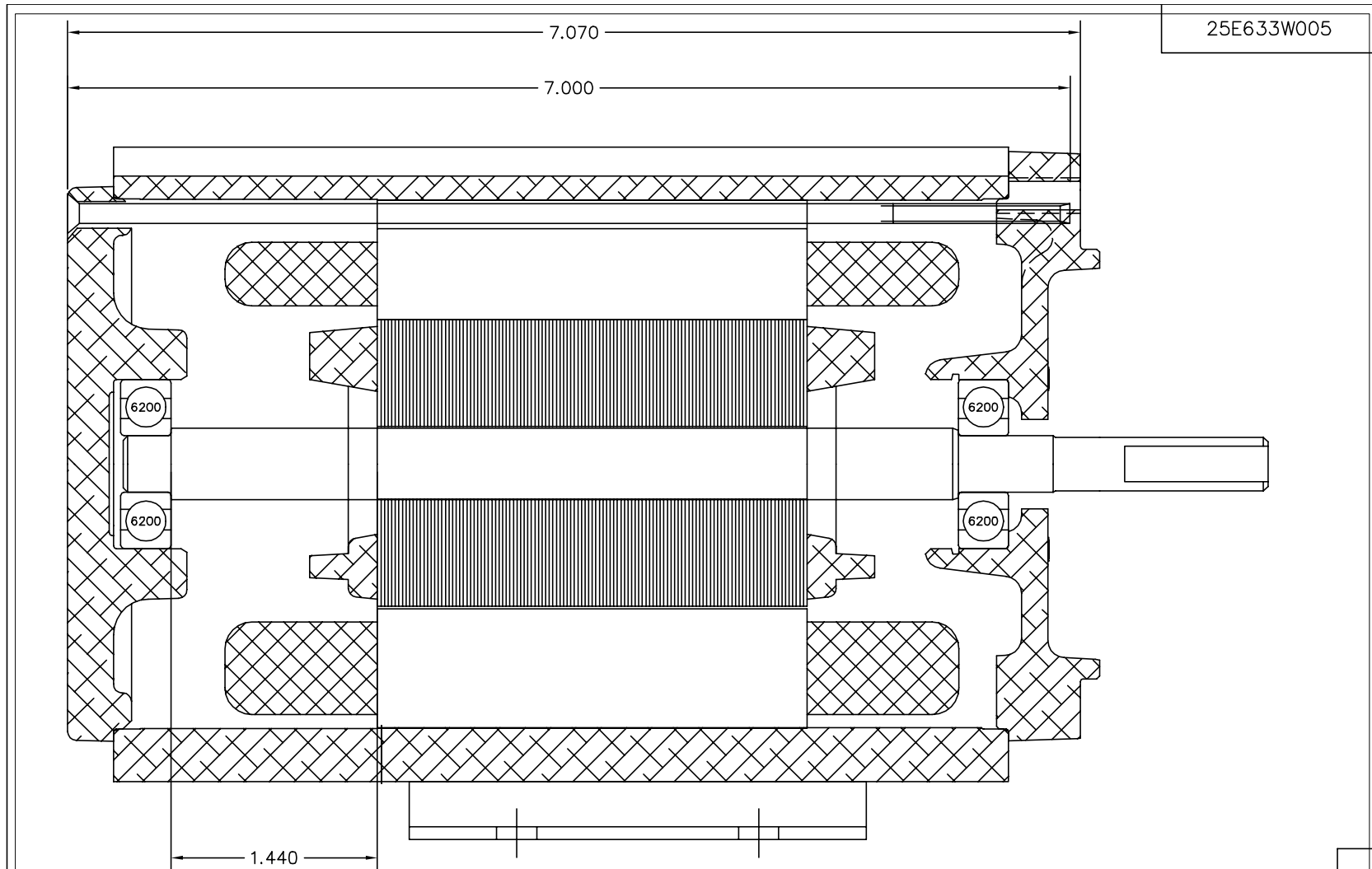

CUSTOMER IS RESPONSIBLE FOR DETERMINING THAT MOTOR PERFORMANCE IS SUITABLE IN THE APPLICATION.

REV. DESC: CORRECT THRUBOLT LOC			
REV. LTR: A	VERSION: 01	TDR: 000000387012	
25E633W005	FILE: \CKA\00026\585	REVISED: 07:08:11 01/27/2006	
	MTL: -	BY: CKRONSO	

**BALDOR ELECTRIC Co.**

LY,25AC MTR EXR TENV W\BASE (25E068W005)

25E633W005

CD1804

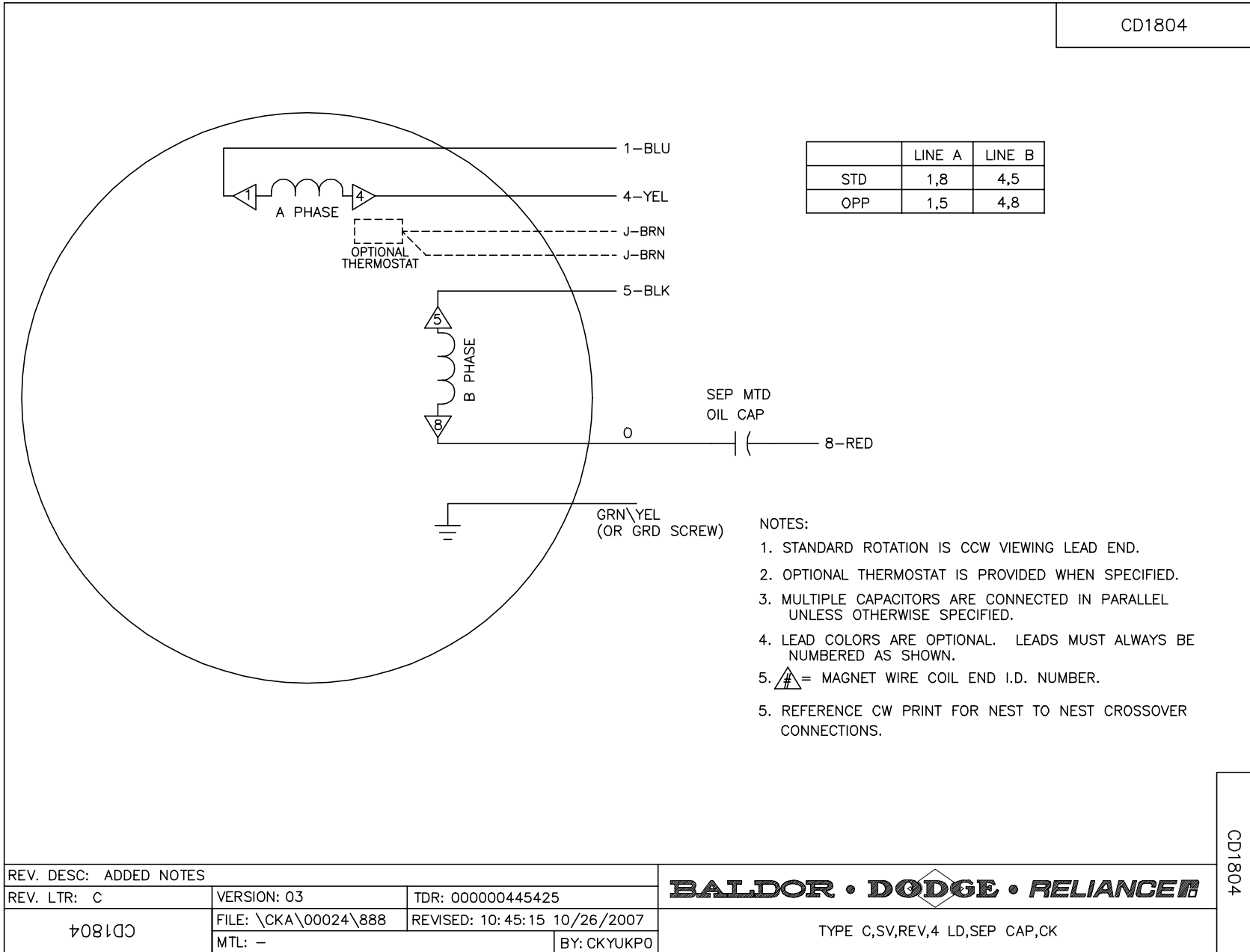

CD1804

REV. DESC: ADDED NOTES			
REV. LTR: C	VERSION: 03	TDR: 000000445425	
CD1804	FILE: \CKA\00024\888	REVISED: 10:45:15 10/26/2007	
	MTL: -	BY: CKYUKPO	

**BALDOR • DODGE • RELIANCE**

TYPE C,SV,REV,4 LD,SEP CAP,CK