



The new generation of Grundfos CR pumps

MOVING THE **LIMITS**



Questions? Call **1-800-810-1053**

be
think
innovate

GRUNDFOS 

WE'VE MOVED THE LIMITS. **YOU CAN TOO.**

The new and extended generation of Grundfos CR pumps moves the limits of the possible with world-class efficiency upgrades and flow sizes up to 1,400 gpm at the best efficiency point.

The world has changed in so many ways since Grundfos invented the world's first vertical multistage centrifugal inline pump back in 1972. But our drive to keep moving the limits of the possible for our customers has always remained the same.

That is why we are so proud to announce the launch of the new generation of Grundfos CR pumps. With three new large flow sizes, up to 580 psi pump pressure and significant energy efficiency upgrades, the CR range opens whole new worlds of opportunity for engineers.

We can't wait to see where you take it.



*The new generation will introduce:
CR 185, CR 215 and CR 255*



WORLD-CLASS EFFICIENCY

The new generation of Grundfos CR has been designed for maximum energy efficiency and performance across the board. From the simulation-driven development of superior hydraulics to little innovations like profiling the leading edges of vanes and introducing a flow-guiding system to eliminate eddies and turbulence.

The outcome is a pump range that offers truly world-class energy efficiency, beating its already outstanding forerunners out of the blocks.



VIRTUALLY UNSTOPPABLE

The CR range is based on more than four decades of continuous adjustment and refinement since the initial launch of the CR pump in 1972, so it is hardly surprising that its reliability is unsurpassed in the industry.

During the design stage, every step has been taken to ensure that pumps in the CR range – often used in applications where uptime is critical – are virtually unstoppable.

To make absolutely sure, we test all our CR pumps thoroughly before they are allowed to leave the factory. And we do mean all of them – not just a random sample here and there.

TURNING SIMULATION INTO REALITY

Following 10,000+ simulations during the design process, the new generation of Grundfos CR was subjected to rigorous real-world testing before going into production.

- Hydraulic performance test
- Vibration test
- Start/stop test
- Corrosion test
- Water hammer test
- High temperature test
- High pressure test
- Shaft seal test
- THD test
- Field tests

See how CR tests were performed at grundfos.com/cr

APPROVALS AND CERTIFICATES

All relevant approvals and certificates are available for pumps in the CR range – including pump & motor performance, materials, food & drinking water, ATEX and offshore.

Find yours at grundfos.com/cr

THE PERFECT BALANCING ACT

For the largest pumps (100 HP+), we have developed a Thrust Handling Device (THD) that improves motor service life and allows for use of standard motors by using discharge pressure for balancing.

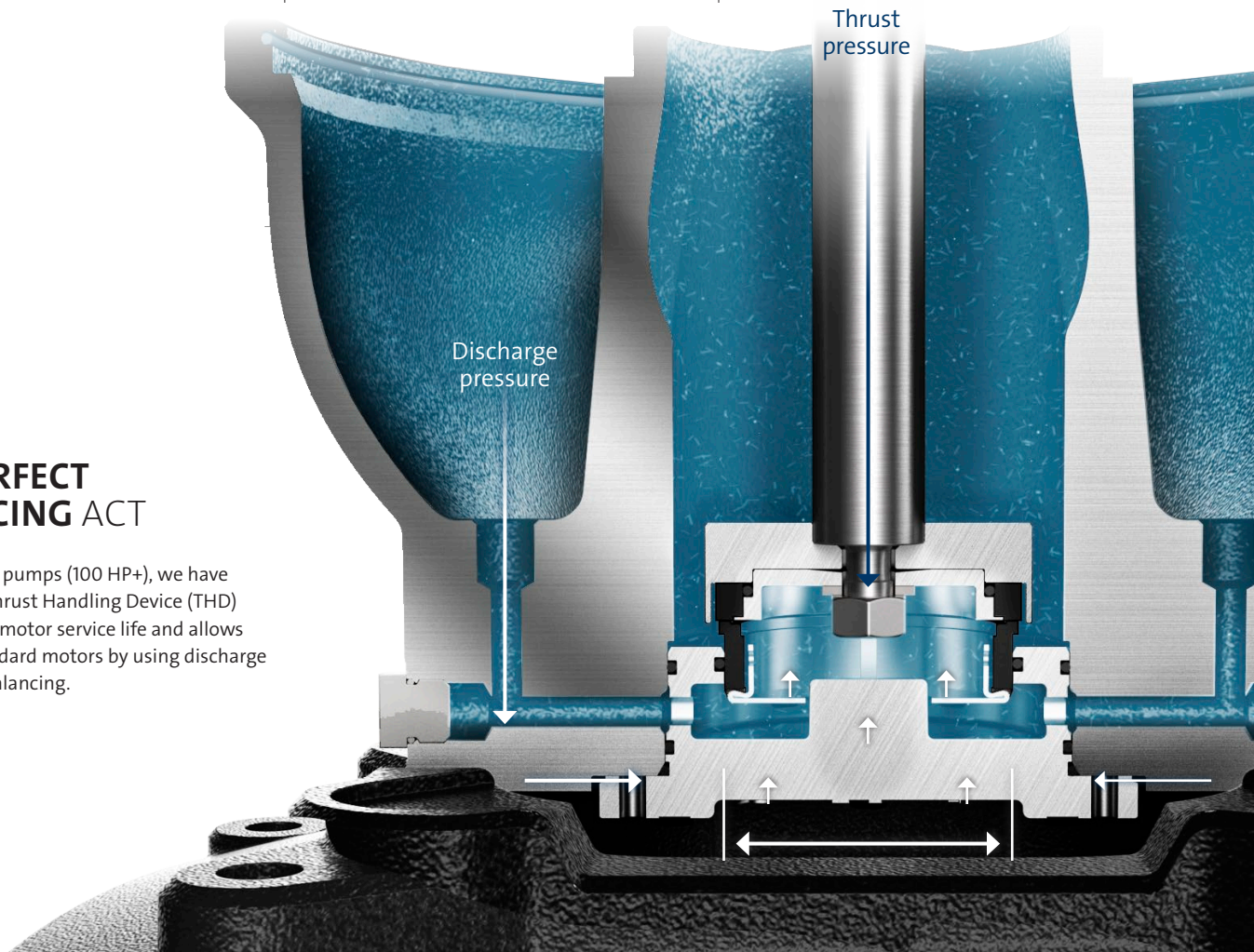



NEW THRUST HANDLING DEVICE (100 HP+)

The Thrust Handling Device (THD) uses discharge pressure to balance axial thrust load and allows for use of standard motors. *(Below 100 HP, axial thrust load is absorbed by reinforced motor bearings)*



FLANGES

Wide selection of flanges ensures that the CR can be mounted in any type of pipework around the world.

PUMP BASE

Optimised inlet with minimal pressure loss lowers the requirements for NPSHr significantly – allowing for much more compact system designs. The outlet port has been similarly optimised to improve hydraulic efficiency and overall pump performance.

CHAMBER

Profiled leading edges of guide vanes reduce turbulence to prevent energy loss in the pumped liquid.

SEAL RINGS

New seal rings reduce pump recirculation to improve overall efficiency.



IMPELLER

The impeller has been optimised for maximum efficiency through extensive simulation-driven design.



NEW SHAFT SEAL

All large CR pumps now use the field-proven Grundfos cartridge shaft seal, which is both highly durable and easy to replace.



TOP COVER

New cupped top cover minimises recirculation by guiding liquid away from the centre of the chamber stack.

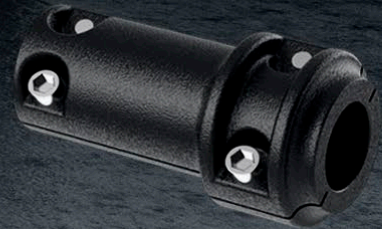



UNLIMITED OPTIONS

The Grundfos CR range gives you almost unlimited customization options, all the way from flow sizes, horizontal/vertical mount and materials to pressure ratings, connections and motor sizes.

With millions of possible variants in the CR range alone, you can always build a Grundfos CR pump to match your exact specification – whatever the application.

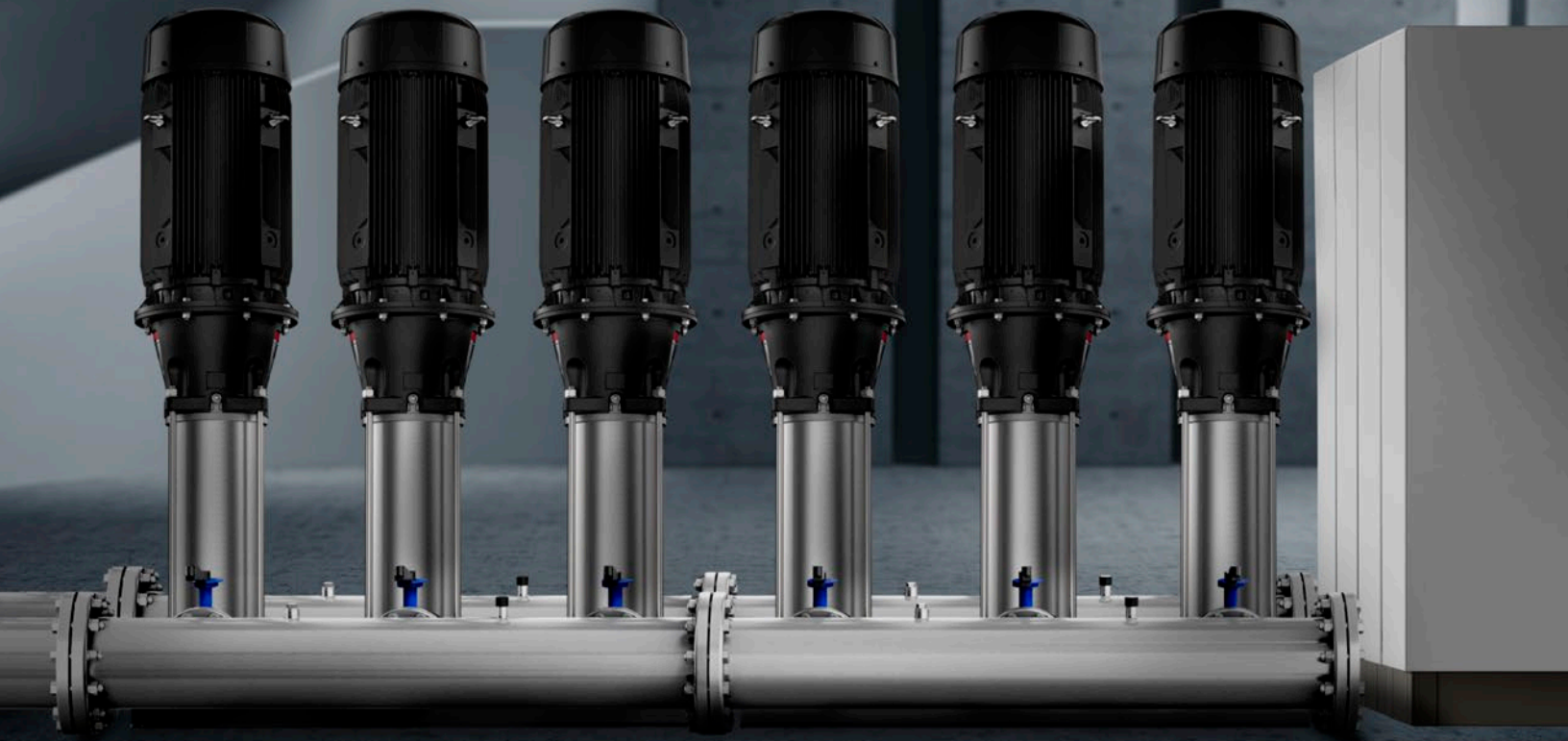

MULTIPUMP SOLUTIONS

Cascade control is the most energy-efficient solution in applications with great fluctuations in demand or rare high peak flow demands.

The CR range forms the backbone of our pretested plug-and-play HYDRO MPC booster systems. These thoroughly performance-optimised systems are available in configurations with up to six CR pumps of your choosing – allowing for flows up to 8,453 gpm.

PERFORMANCE CONTROL

In most applications, you can significantly improve energy efficiency by controlling pump performance – particularly if there is great variation in demand.

The Grundfos CUE drives are specifically optimised for pump operation and available in all voltages and frequencies for pumps in the CR range.

CR pumps up to 30 HP can be fitted with either integrated drives (CRE) or stand-alone drives (CUE).

For the large CR/CRN range, we offer plug-and-play drives that can even be preconfigured and tested to suit your specific needs.

All CR pumps can be connected to a CIU unit to enable communication with and data transfer to SCADA and BMS systems.



CUSTOMIZE YOUR CR



DIFFICULT LIQUIDS

To prevent contamination by toxic, aggressive, odorous, flammable, crystallising, hardening and/or sticky liquids, we offer magnetic-drive pumps or CRN pumps with double shaft seals (either back-to-back or tandem).

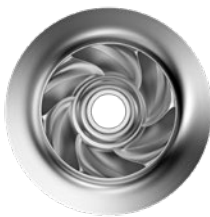

ULTRA-PURE WATER

To meet the special challenges of ultra-pure water applications, CRN pumps are available in migration-free execution (carbon-free and/or clean & dry models).



HORIZONTAL MOUNT

Horizontal mount CR pumps are available on request for installations with limited height, in earthquake-prone areas or aboard ships.



HIGH TEMPERATURE LIQUIDS

For liquid temperatures in excess of 248°F, we recommend our air-cooled seal solution for CRN pumps. These air-cooled tops can handle water temperatures up to 356°F and oil temperatures up to 464°F.

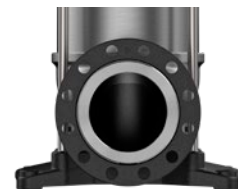

LOW NPSH

CR pumps can be fitted with a dedicated low-NPSH stage to avoid cavitation in installations with poor inlet conditions.



ATEX/EX

Pumps in the CR range can be delivered with explosion-proof motors and ATEX approval on request.

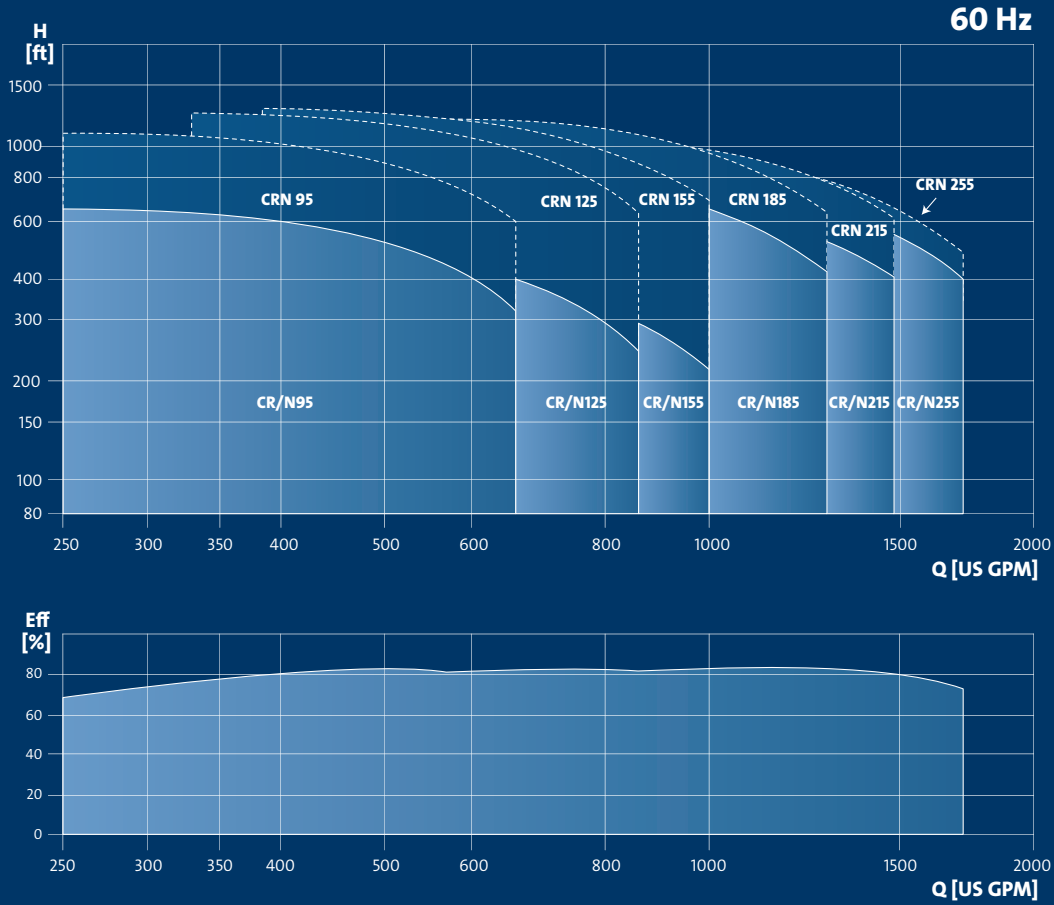

US.GRUNDFOS.COM/NEWCR

Visit grundfos.us/pei to learn more about Department of Energy (DOE) pump energy index (PEI) requirements and PEI ratings on specific Grundfos models.