



STS21/STS31

SUBMERSIBLE SUMP PUMPS

FEATURES

Corrosion-resistant construction.

A mechanical seal protects the motor. It consists of ceramic/silicon carbide seal faces with BUNA elastomers.

Glass-filled thermoplastic impeller and motor cover.

Upper and lower heavy duty ball bearing construction.

Air-filled motor mounted in aluminum housing.

Motor is permanently lubricated for extended service life and is powered for continuous operation. All ratings are within the working limits of the motor.

Includes vertical float switch and mounting pipe. Adjustable for various liquid levels.

Complete unit is lightweight, portable and easy to service.



Underwriters Laboratories
File #E83318

APPLICATIONS

Specially designed for the following uses:

- Basement draining
- Water transfer
- Dewatering
- Filtered Effluent

SPECIFICATIONS

- Discharge size: 1 ½" NPT.
- Capacities: to 38 GPM.
- Maximum head: 25 feet TDH.
- Maximum solids: ¾" spherical
- Temperature: 104° F (40° C) maximum liquid temperature.
- Mechanical seal: ceramic/silicon carbide faces with BUNA elastomers.

MOTOR

- Single phase, 3450 RPM, 60 Hz
 - STS21, ¼ HP, 115 V, 2.5 amps.
 - STS31, ½ HP, 115 V, 4.5 amps.
- Built-in thermal overload protection with automatic reset.
- Permanent-split-capacitor type.
- Class B insulation.
- Air filled design.
- Power cord length: 20 feet with NEMA 5-15P plug.

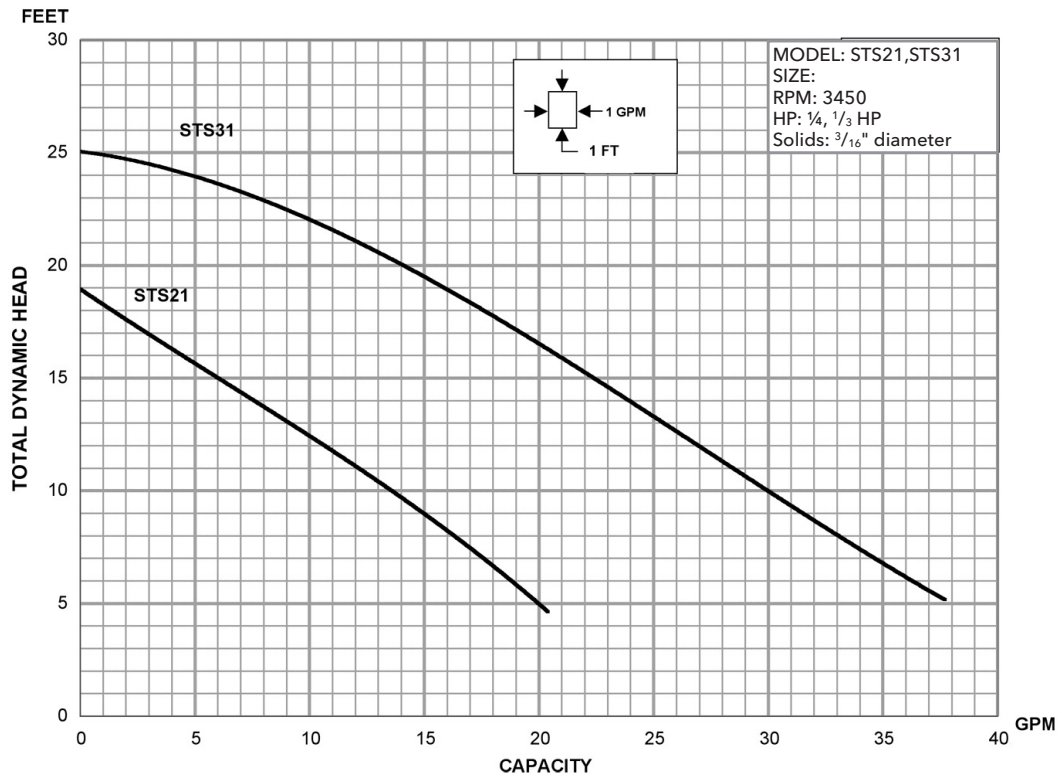

MODEL INFORMATION

| Part No. | HP | Volts | Phase | Hz | Max. Amps | RPM | W1 (in.) | W2 (in.) | H1 (in.) | H3 (in.) | Wt. lbs. | Switch |
|----------|-----|-------|-------|----|-----------|------|----------|----------|----------|----------|----------|-----------|
| STS21V | 1/4 | 115 | 1 | 60 | 2.5 | 3450 | 5.9 | 9.6 | 10.1 | 14.7 | 10.0 | Vertical |
| STS31V | 4.5 | | | | 10.4 | | | | 15.1 | | | |
| STS31A1 | 1/3 | | | | | 3545 | | NA | | | | Tether |
| STS31M | | | | | | | | | | | | No Switch |

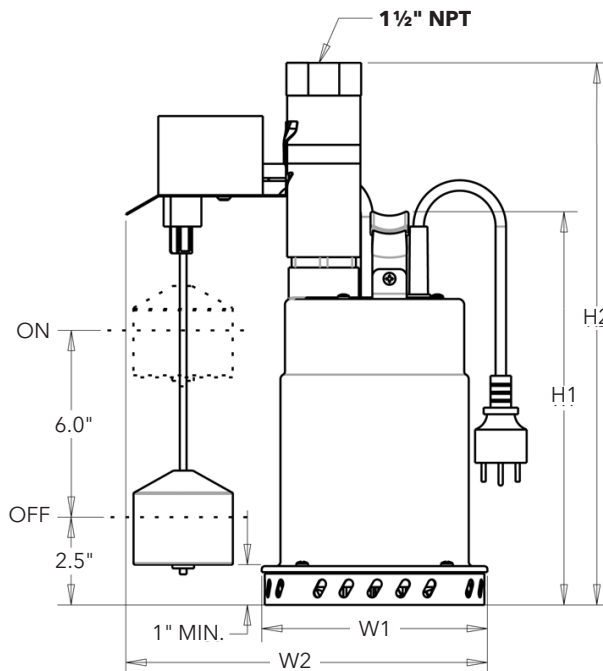

COMPONENTS

| Item No. | Description |
|----------|--|
| 1 | SJE Vertical Master II Switch includes Mounting Hardware |
| 2 | Upper and Lower Ball Bearings |
| 3 | Motor - PSC Air Filled |
| 4 | Lip Seal - BUNA N |
| 5 | Mechanical Seal - Ceramic/Silicon Carbide |
| 6 | Pump Casing - Stainless Steel |
| 7 | Suction Strainer - Stainless Steel |
| 8 | Impeller - PPO |
| 9 | Run Capacitor |
| 10 | Power Cable - SJTW |
| 11 | Pump Handle |
| 12 | 1½" Discharge Pipe - Connection Kit |
| 13 | Motor cover - PP |
| 14 | Motor housing - aluminum |

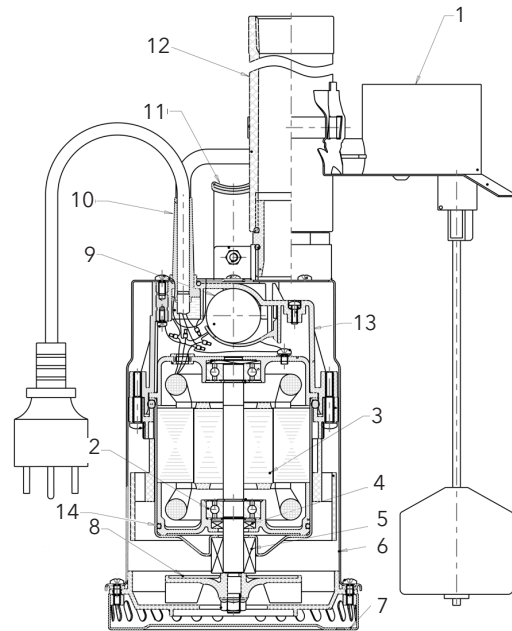

xylem
Let's Solve Water

Xylem, Inc.
2881 East Bayard Street Ext., Suite A
Seneca Falls, NY 13148
Phone: (866) 325-4210
Fax: (888) 322-5877
www.gouldswatertechnology.com

Goulds is a registered trademark of Goulds Pumps, Inc. and is used under license.
© 2012 Xylem Inc. BSTS2131 R1 February 2013