

GRUNDFOS NBS

The N-series offers three different end-suction models: the frame-mounted NK, close-coupled NB and split-coupled NBS.

The N-series delivers industry leading efficiencies that future-proof them against government efficiency regulations. The NBS is designed to bring faster installation, greater efficiency and reliability, along with easier serviceability throughout the pump's life. With up to a 35% smaller footprint, Lifetime Alignment Guarantee, back-pull out design and a new and revolutionary hard-faced seal designed to improve reliability and reduce service costs, the NBS delivers on our promise that HVAC from Grundfos — it's everyone's comfort zone.



KEY FEATURES AND BENEFITS

Installation

- No baseplate or grouting required reducing installation costs
- No alignment required between the pump and motor with our Lifetime Alignment Guarantee — eliminating laser alignment costs and reducing installation time
- Optimized, space-saving design has up to a 35% smaller footprint compared to traditional frame-mounted design pumps
- Top centerline discharge design allows for self-venting and more compact piping designs

Efficiency and Reliability

- Industry leading efficiencies you can count on, because of advanced Computational Fluid Dynamics (CFD)
- New Silicon Carbide (SiC) / Silicon Carbide (SiC) hard faced seal's robust design offers increased temperature range, better abrasives handling and longer life versus standard designs (standard on all N-Series pumps)
- Backed by our Lifetime Alignment Guarantee so you never have to worry about undue wear and tear on mechanical seals, bearings and energy losses due to misalignment
- Optimized, stainless-steel impeller design increases efficiency and reduces NPSH required
- Balanced impellers reduce noise and vibration for quiet operation and prolong seal and bearing life

- 4" and above models have a internal dual-volute design for increased efficiency, lower life-cycle costs and prolonged seal and bearing life
- Integrally cast diffuser vane reduces turbulence

Serviceability

- Foot-mounted volute for increased pump stability
- Spacer-coupling design allows for back pull-out and easy access to mechanical seal without removing the motor or disturbing piping

APPLICATIONS

- HVAC (Cooling/Heating)
- District Energy
- Industrial
- Water Utility

TECHNICAL DATA

NBS	
FLOW, Q:	max. 5,800 gpm
HEAD, H:	max. 450 ft
LIQUID TEMPERATURE:	-13°F to 248°F (Optional: 284°F)
WORKING PRESSURE:	max. 232 psi (Optional: 362 psi)
HP RANGE	max. 250 hp
SPEED	3600, 1800, and 1200 RPM
DISCHARGE SIZES:	1.25 to 10 in. • Centerline: 1.25–6 in • Tangential: 8–10 in

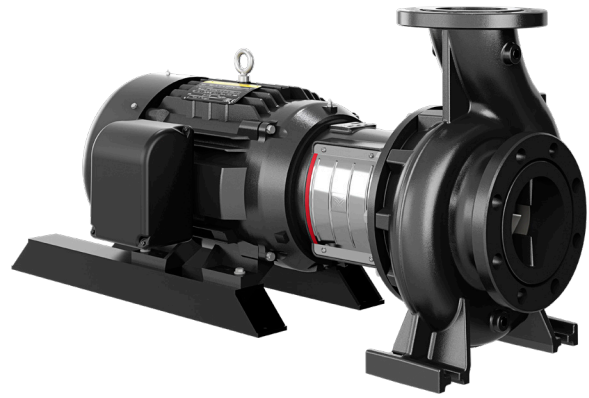

PERFORMANCE DATA

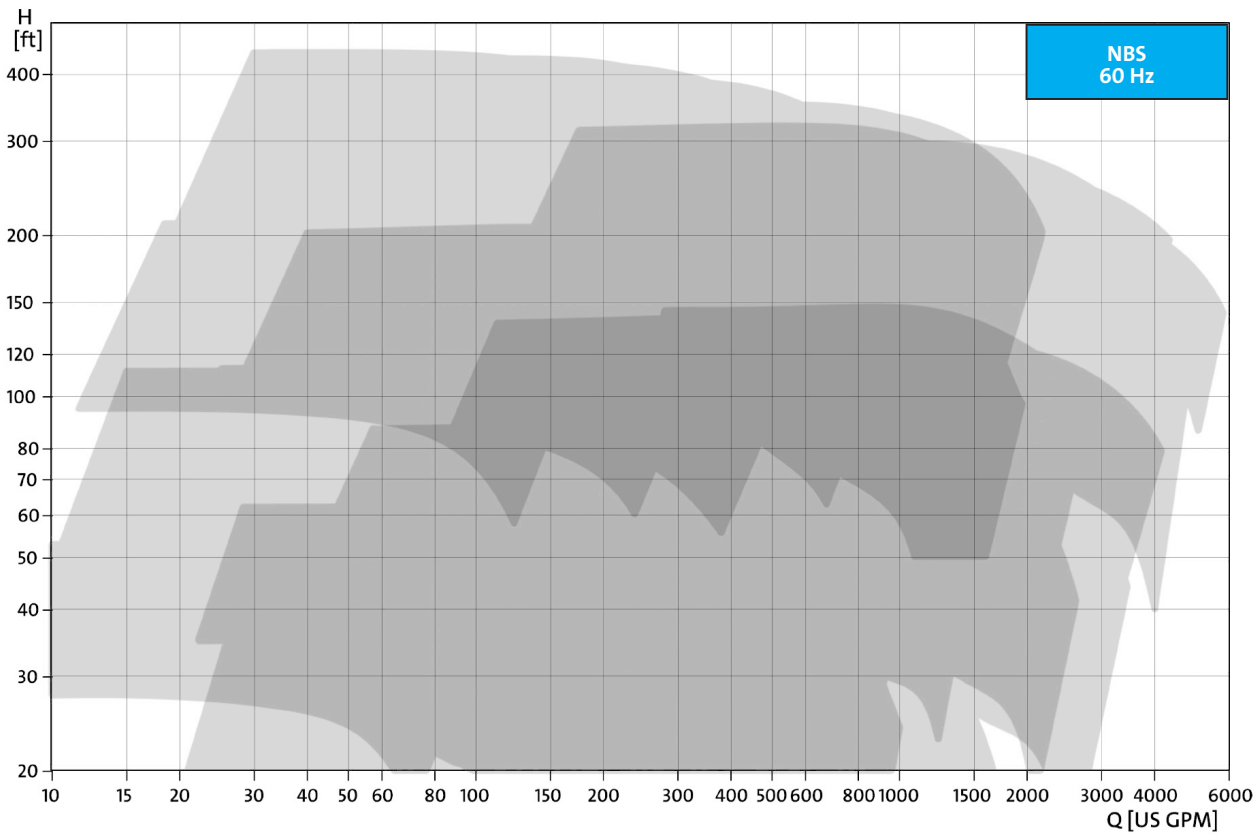

Visit grundfos.us/pei to learn more about Department of Energy (DOE) pump energy index (PEI) requirements and PEI ratings on specific Grundfos models.

Order Online: www.PumpCatalog.com

Grundfos Americas
Brookshire, TX 77423

www.grundfos.us
www.grundfos.ca
www.grundfos.mx

