

EOM

Engineering
Operation &
Maintenance

WILDEN®

VELOCITY PLASTIC PUMP

PUMP DESIGNATION SYSTEM

LEGEND



V150 / XXXXX / XXX / XX / XXX / XXXX

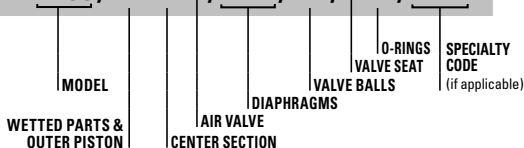

MATERIAL CODES

MODEL

V150 = 13 mm (1/2") VELOCITY
A150V = 13 mm (1/2") ACCU-FLO™

WETTED PARTS & OUTER PISTON

KK = PVDF / PVDF
PP = POLYPROPYLENE / POLYPROPYLENE

AIR CHAMBER/CENTER BLOCK

PP = POLYPROPYLENE

AIR VALVE

A = ALUMINUM (ACCU-FLO Only)
E = PET

DIAPHRAGMS

TSS = FULL-STROKE PTFE W/ SANIFLEX
BACK-UP O-RING
ZWS = WIL-FLEX™ [Santoprene®
(Three Black Dots)]

VALVE BALLS

TF = PTFE (White)
WF = WIL-FLEX™ [Santoprene®
(Three Black Dots)]

VALVE SEAT

K = KYNAR
P = POLYPROPYLENE

VALVE SEAT O-RING

TV = PTFE-ENCAP. FKM
WF = WIL-FLEX (Santoprene®)

SPECIALTY CODES

0150 Accu-Flo, 24V DC Coil
0151 Accu-Flo, 24V AC/12V Coil
0155 Accu-Flo, 110V AC Coil

CAUTIONS & WARNINGS



PUMP TEMPERATURE LIMITS:

PVDF and Polypropylene 4°C – 79°C (40°F - 175°F)



CAUTION: Maximum temperature limits are based upon mechanical stress only. Certain chemicals will significantly reduce maximum safe operating temperatures. Consult Chemical Resistance Guide for chemical compatibility and temperature limits.



CAUTION: Do not exceed 6.9 bar (100 psig) air supply pressure.



CAUTION: Verify the chemical compatibility of the process and cleaning fluid to the pump's component materials in the Chemical Resistance Guide.



CAUTION: Plastic series pumps are made from plastic that is not UV stabilized. Direct sunlight exposure for prolonged periods can cause deterioration of plastic.



CAUTION: V150 pumps are not submersible.



CAUTION: Always wear safety glasses when operating pump. If diaphragm rupture occurs, fluid being pumped may be forced out air exhaust



CAUTION: Before any maintenance or repair is attempted, the compressed air line to the pump should be disconnected and all air pressure allowed to bleed from the pump.



CAUTION: Ensure that the air supply line is clear of debris. Use of a 5 μ (micron) in-line air filter is recommended.

DIMENSIONAL DRAWING

V150 PLASTIC

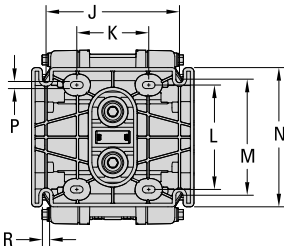
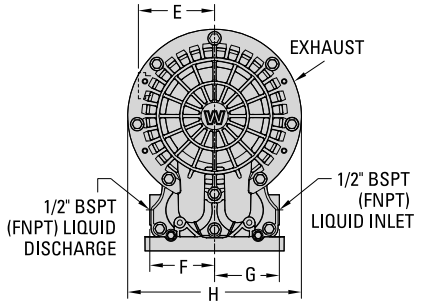
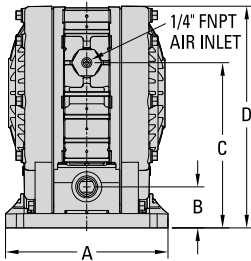

DIMENSIONS

ITEM	METRIC (mm)	STANDARD (inch)
A	178	7.0
B	45	1.8
C	181	7.1
D	243	9.6
E	83	3.3
F	71	2.8
G	71	2.8
H	190	7.5
J	146	5.8
K	79	3.1
L	114	4.5
M	127	5.0
N	152	6.0
P	8	0.3
R	8	0.3

LW0477 REV. A

WIL-41010-E-01

DIMENSIONAL DRAWING

V150 PLASTIC - HORIZONTAL

2X 1/2" BSPT
(FNPT) LIQUID
DISCHARGE

2X 1/2" BSPT
(FNPT)
LIQUID INLET

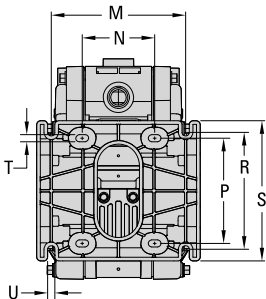
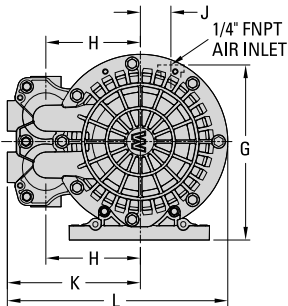
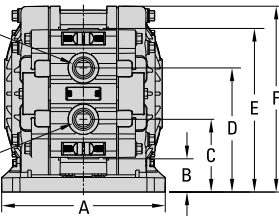

DIMENSIONS

ITEM	METRIC (mm)	STANDARD (inch)
A	178	7.0
B	36	1.4
C	79	3.1
D	135	5.3
E	178	7.0
F	202	8.0
G	190	7.5
H	103	4.0
J	33	1.3
K	145	5.7
L	240	9.4
M	146	5.8
N	79	3.1
P	114	4.5
R	127	5.0
S	152	6.0
T	8	0.3
U	8	0.3

LW0478 REV. A

WIL-41010-E-01

DIMENSIONAL DRAWING

A150V PLASTIC

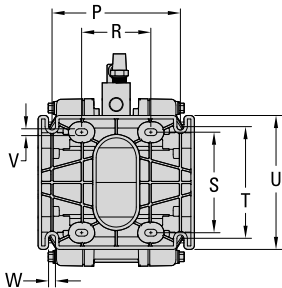
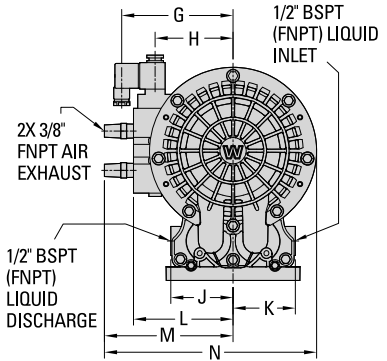
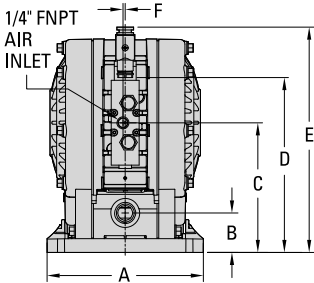

DIMENSIONS

ITEM	METRIC (mm)	STANDARD (inch)	ITEM	METRIC (mm)	STANDARD (inch)
A	178	7.0	L	113	4.5
B	45	1.8	M	146	5.8
C	148	5.8	N	241	9.5
D	199	7.8	P	146	5.8
E	256	10.1	R	79	3.1
F	3	0.1	S	114	4.5
G	127	5.0	T	127	5.0
H	89	3.5	U	152	6.0
J	71	2.8	V	8	0.3
K	71	2.8	W	8	0.3

LW0479 REV. A

V150 TPE-FITTED PERFORMANCE CURVE

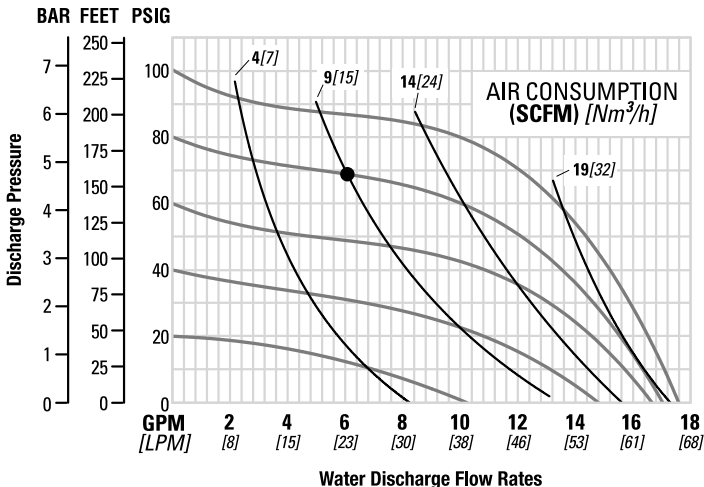

Flow rates indicated on chart were determined by pumping water.

For optimum life and performance, pumps should be specified so that daily operation parameters will fall in the center of the pump's performance curve.

Ship WeightPVDF 3.7 kg (10 lb)
 Polypropylene 3 kg (8 lb)
 Air Inlet 13 mm (1/2")
 Inlet 13 mm (1/2")
 Outlet 13 mm (1/2")
 Suction Lift4.8 m Dry (16')
 7.9 m Wet (26')
 Disp. per Stroke¹ 0.11 L (0.03 gal)
 Max. Flow Rate64 lpm (17 gpm)
 Max. Size Solids.....1.6 mm (1/16")

¹Displacement per stroke was calculated at 4.8 bar (70 psig) air inlet pressure against a 2.1 bar (30 psig) head pressure.

Example: To pump 34 lpm (5.9 gpm) against a discharge head of 4.8 bar (70 psig) requires 5.5 bar (80 psig) and 15.3 Nm³/h (9 scfm) air consumption.

Caution: Do not exceed 6.9 bar (100 psig) air supply pressure.

V150 PTFE-FITTED PERFORMANCE CURVE

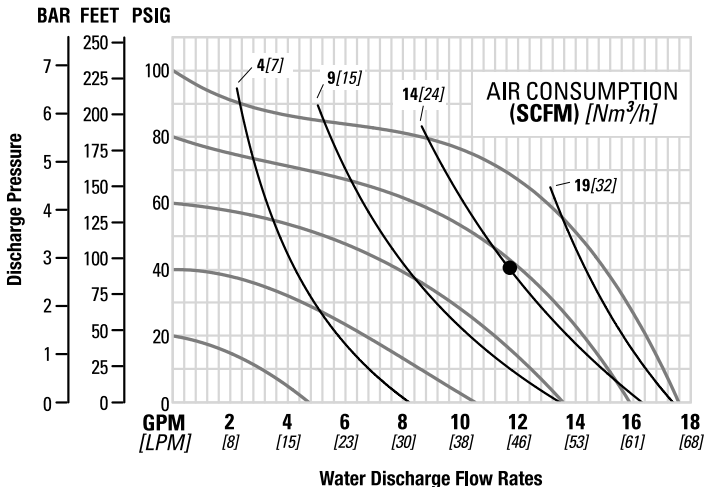

Flow rates indicated on chart were determined by pumping water.

For optimum life and performance, pumps should be specified so that daily operation parameters will fall in the center of the pump's performance curve.

Ship WeightPVDF 3.7 kg (10 lb)
 Polypropylene 3 kg (8 lb)
 Air Inlet 13 mm (1/2")
 Inlet 13 mm (1/2")
 Outlet 13 mm (1/2")
 Suction Lift5.1 m Dry (16.9')
 7.9 m Wet (26')
 Disp. per Stroke¹ 0.11 L (0.03 gal)
 Max. Flow Rate64 lpm (17 gpm)
 Max. Size Solids.....1.6 mm (1/16")

¹Displacement per stroke was calculated at 4.8 bar (70 psig) air inlet pressure against a 2.1 bar (30 psig) head pressure.

Example: To pump 5.7 lpm (11.5 gpm) against a discharge head of 2.8 bar (40 psig) requires 5.5 bar (80 psig) and 23.8 Nm³/h (14 scfm) air consumption.

Caution: Do not exceed 6.9 bar (100 psig) air supply pressure.

A150V PERFORMANCE CURVE

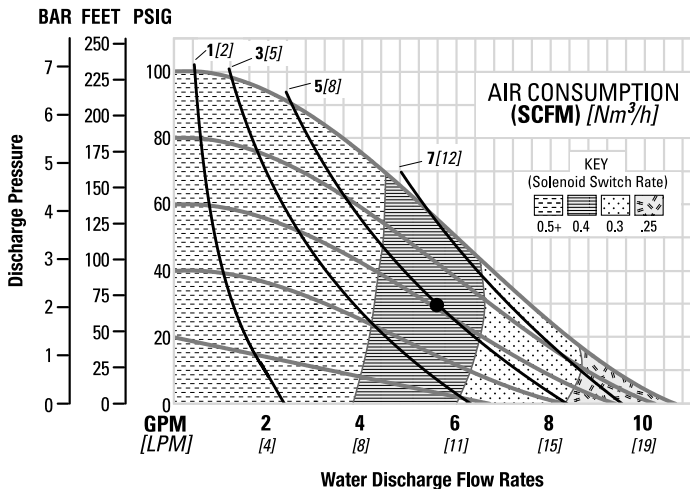

Flow rates indicated on chart were determined by pumping water.

For optimum life and performance, pumps should be specified so that daily operation parameters will fall in the center of the pump's performance curve.

Ship WeightPVDF 3.7 kg (10 lb)
 Polypropylene 3 kg (8 lb)
 Air Inlet 13 mm (1/2")
 Inlet 13 mm (1/2")
 Outlet 13 mm (1/2")
 Suction Lift5.1 m Dry (16.9')
 7.9 m Wet (26')
 Disp. per Stroke¹ 0.11 L (0.03 gal)
 Max. Flow Rate39 lpm (10.5 gpm)
 Max. Size Solids.....1.6 mm (1/16")

¹Displacement per stroke was calculated at 4.8 bar (70 psig) air inlet pressure against a 2.1 bar (30 psig) head pressure.

Example: To pump 18.9 lpm (5 gpm) against a discharge head of 2.1 bar (30 psig) requires 4.1 bar (60 psig) and 8.4 Nm³/h (5 scfm) air consumption.

Caution: Do not exceed 6.9 bar (100 psig) air supply pressure.

A150V 70/30 OPERATING CONDITION

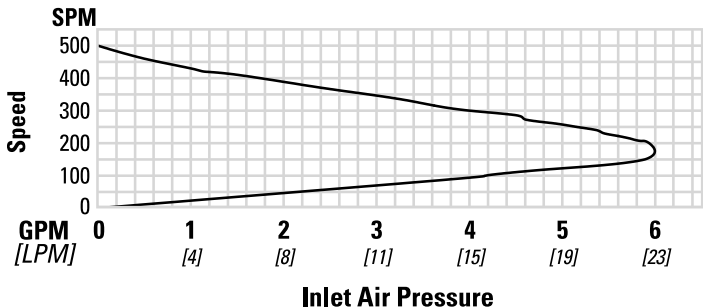

This curve demonstrates the flow created when the stroke rate is varied under static air and fluid pressure conditions. This curve can be applied to different pressure conditions to estimate the change in flow due to stroke rate.

V150 DRY SUCTION-LIFT CURVE

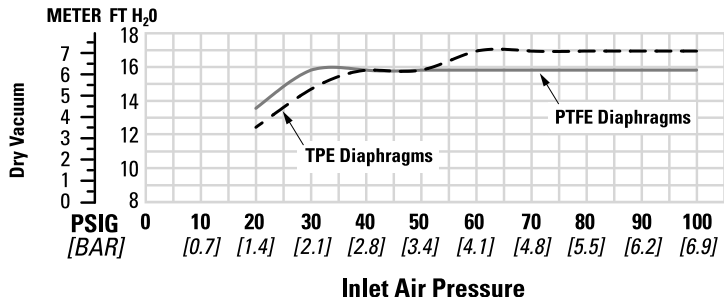

Suction lift curves are created using pumps operating at 305 m (1000') above sea level. This chart is meant to be a guide only. There are many variables which can affect the pump's operating characteristics. Suction lift can be affected by the number of intake/discharge elbow, viscosity of pumping fluid, elevation (atmospheric pressure), pipe friction losses and other factors.

Caution: Do not exceed 6.9 bar (100 psig) air supply pressure.

SUGGESTED INSTALLATION

PUMP SELECTION: Ensure that pump materials of construction are compatible with the pumping media and the immediate surroundings the pump will be subjected to. Refer to the Wilden Chemical Resistance Guide. For optimum life and performance, the pump size should be specified so that daily operation parameters are not near the pump's maximum rated performance capabilities.

INSTALLATION: The pump has two foot mount configurations and can be mounted in any orientation. The pump can be mounted in place or left free standing for use in multiple locations. If the pump is to be mounted in place, it is suggested to attach the foot to the desired surface using 4 screws (not supplied) and then attach the pump to the foot using the 4 supplied #12 screws.

PIPING: The suction and discharge piping diameter should be equivalent or larger than the diameter of pump connection, the length and complexity of the suction and discharge piping should be minimized, unnecessary elbows, bends and fittings should be avoided, all in an effort to reduce friction losses.

The suction hose must be non-collapsible. If rigid piping is used, it should be supported independently of the pump. In addition, the piping should be aligned to avoid placing stress on the pump fittings.

When used in self-priming applications, it is critical that all fittings and connections are airtight or a reduction or loss of pump suction capability will result. Ensure that the suction lift requirement is within the pump model's capability.

AIR SUPPLY: Every pump should have an airline large enough to supply the volume of air necessary to achieve the desired pumping rate. Air pressure to the pump should not exceed a maximum of 6.9 bar (100 psig). For best results, the pumps should use a 5 μ (micron) air filter to eliminate air-line contaminants, a needle valve and pressure regulator.

SOLENOID CONTROL: When start-stop operation of a standard air valve equipped pump is controlled by a solenoid valve in the air line, a three-way (3/2) solenoid valve should be used to vent pressurized air between the solenoid and pump when the pump is stopped.

REMOTE SOLENOID OPERATION: When the remote solenoid option is being used, a five-way (5/2) solenoid valve must be used to control the operation of the pump. Minimize the length of tubing between the solenoid and the two pump inlets to improve pump performance.

PUMP OPERATION: Tighten all hardware to suggested torque specifications prior to initial start-up. Once installation is complete, pump operation can be started by opening the air shut-off valve (do not exceed the pump's maximum rated pressure). The pressure regulator and needle valve are used to adjust the speed of the pump.

BASIC TROUBLESHOOTING

Pump will not run or runs slowly:

1. Ensure the air inlet pressure is 0.3 bar (5 psig) above the start-up pressure of the pump.
2. Ensure the differential pressure (difference between the air inlet pressure and fluid discharge pressure) is not less than 0.7 bar (10 psig).
3. Check air line/filter for blockage/debris. Check for obstruction in the air passageways of the pump.
4. Check for objects in the pump that would obstruct the movement of internal parts.
5. Check for severe air leakage (blow-by) coming from the air exhaust. This could indicate a failed O-ring seal or worn air valve assembly.
6. Inspect for check valve failure. A worn check ball can get stuck in the seat. A check ball can swell and become stuck if not compatible with fluid pumped. Replace if necessary.

Pump runs but little or no product flows:

1. Check for cavitation. Confirm vacuum required to lift the fluid is not greater than the vapor pressure of the fluid being pumped. Slow pump speed to allow viscous fluids to flow into liquid chambers.
2. Ensure that the suction lift requirement is within the pump model's capability.
3. Inspect for check valve failure. A worn check ball can get stuck in the seat. A check ball can swell and become stuck if not compatible with fluid pumped. Replace if necessary.

Air bubbles in pump discharge:

1. Check for ruptured diaphragm.
2. Check tightness of outer piston to shaft.
3. Check integrity of O-ring seals, especially intake side of manifold.
4. Ensure pipe connections are airtight.

Product comes out of air exhaust:

1. Check for ruptured diaphragm.
2. Check tightness of outer piston to shaft.

DISASSEMBLY / REASSEMBLY

Tools Required:

- 5/16" Socket Wrench
- 3/8" Socket Wrench
- Snap-Ring Pliers

CAUTION: Before any maintenance or repair is attempted, the compressed air line to the pump should be disconnected and all air pressure allowed to bleed from the pump.

1. Insert air valve assembly (item 1) into center section (item 5) until fully seated. Install retaining ring (item 6) in groove in center section air valve bore.
2. For PTFE fitted pumps, install back-up seals (item 24) on to surfaces of center section (item 5).
3. Slide inner pistons (item 23) on to ends of shaft.
4. Slide diaphragms (item 25) on to ends of shaft.
5. Install outer pistons on to ends of shaft (item 26). Tighten to specified torque (110 lb-in). Over-tightening could damage outer piston. Use of removable, thread-locking compound is recommended.
6. Install four (4) ball check cartridges (item 19) into manifold (item 15).
NOTE: cartridges must be installed in correct orientation. Align grooves on cartridge with ribs in manifold. Cartridge will be flush with end of the manifold if installed correctly.
7. Install four (4) manifold O-rings (item 20) on to ends of manifold (item 15).
8. Place upper screw boss in manifold (item 15) in between the flanges at the bottom of the center section (item 5). Ensure t-nuts (item 17) are properly inserted into manifold screw bosses.
9. Place center section-manifold assembly between two liquid chambers (item 14), taking care to align the large bore on liquid chamber over the diaphragm and the two small bores over the manifold.
10. Place in vise and carefully press assembly together. Take care not to pinch or damage sealing O-rings. If a large enough vise is not available, the pump fasteners can be used to join the assembly together. A "cross-pattern" tightening procedure must be used to gradually bring the assembly together.
11. Fasten liquid chambers (item 14) to center section (item 5) and manifold (item 15) using 22 ¼-20 screws (item 10). Tighten fasteners to specified torque (60 lb-in). Over-tightening fasteners could damage center section or manifold.
12. Press muffler element (item 9) into muffler frame (item 10) and install the assembly into the muffler cavity (opposite the air inlet) of center section (item 5). Fasten with 4 #12 screws (item 11).
13. There are two mounting options for the base assembly (item 27). Install 4 #12 screws (item 12) into the locations shown in the graphic on both sides of the pump.
14. Install one (1) pipe plug (item 16) into one (1) inlet port of the manifold (item 15). Install one (1) pipe plug into one (1) discharge port on manifold.

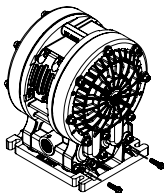

VERTICAL MOUNTING

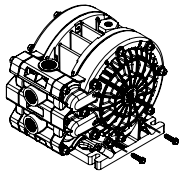

HORIZONTAL MOUNTING

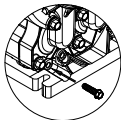

VERTICAL MOUNTING

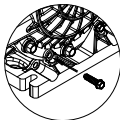

HORIZONTAL MOUNTING

EXPLODED VIEW

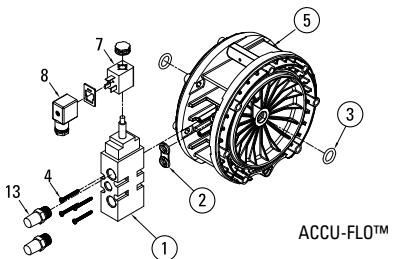
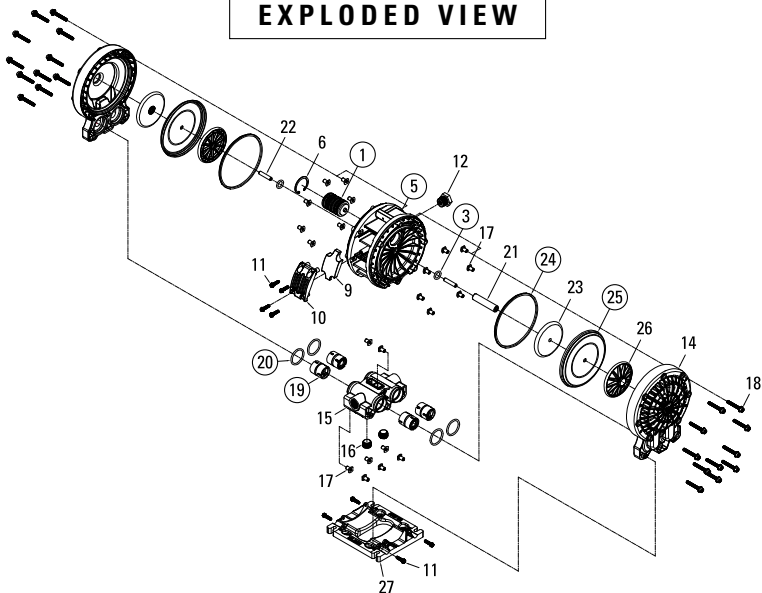

ACCU-FLO™

LW0480 REV. A

ALL CIRCLED PART IDENTIFIERS ARE INCLUDED IN REPAIR KITS

WIL-41010-E-01

PARTS LISTING

Item	Description	Qty.	V150 /PPPE/.../P/N	A150V /PPPPA/.../P/N	V150 /KKPPE/.../P/N	A150V /KKPPA/.../P/N
AIR DISTRIBUTION COMPONENTS						
1	Air Valve Assembly¹	1	01-2044-99		01-2044-99	
	Air Valve Assembly, Solenoid²	1		01-2014-99		01-2014-99
2	Gasket, Solenoid Valve	1		01-2640-56		01-2640-56
3	O-Ring, Shaft (-208, Ø.609" x Ø.139")	2	01-3214-50			
4	Screw, Pan Head Torx, Solenoid Air Valve (#6-19 PLST x 1-1/4")	4		01-6134-03		01-6134-03
5	Center Section Assembly, Air Valve³	1	01-3171-20		01-3171-20	
	Center Section Assembly, Accu-Flo™⁴	1		01-3169-20		01-3169-20
6	Retaining Ring	1	01-2644-09		01-2644-09	
7	Coil, 24V DC	1		00-2110-99-150		00-2110-99-150
	Coil, 24V AC / 12V DC	1		00-2110-99-151		00-2110-99-151
	Coil, 110V AC	1		00-2110-99-155		00-2110-99-155
8	Connector, Solenoid	1		00-2130-99		00-2130-99
9	Muffler Element	1	01-3244-26		01-3244-26	
10	Muffler Frame	1	01-3184-20		01-3184-20	
11	Screw, Hex Washer Head Tri-Lobe (#12-11 x 7/8")	4	01-6114-03		01-6114-03	
12	Bushing, Reducer (1/2" NPT to 1/4" NPT)	1	01-6950-20		01-6950-20	
13	Muffler, 3/8" MNPT	2		95-3240-07		95-3240-07
WETTED PATH COMPONENTS						
14	Liquid Chamber	2	01-5014-20		00-5014-21	
15	Manifold, Four Port, 1/2" (NPT)	1	01-5164-20		00-5164-21	
	Manifold, Four Port, 1/2" (BSP)	1	01-5164-20-14		00-5164-21-14	
16	Manifold Pipe Plug 1/2" (NPT)	2	01-7014-20		00-7014-21	
17	T-Nut, 1/4"-20	22		01-6544-03		
18	Screw, Hex Washer Head (1/4"-20 x 1-3/4")	22		01-6185-03		
BALL CHECK CARTRIDGE / MANIFOLD O-RINGS						
19	Ball Check Cartridge	4	*			*
20	Manifold O-Ring, TPE Fitted (Ø1.421 x Ø.139")	4	*			*
	Manifold O-Ring, PTFE Fitted (-221, Ø1.424 x Ø.139")	4	*			*
FULL-STROKE RUBBER / TPE / PTFE COMPONENTS						
21	Shaft	1		01-3849-03		
22	Shaft Stud, 5/16"-18 X 1-1/2"	2		01-6154-03		
23	Piston, Inner	2		01-3740-20		
24	Diaphragm, Back-Up Seal PTFE only	2		*		
25	Diaphragm, Primary	2		*		
26	Piston, Outer	2	01-4640-20		01-4640-21	
REMOVABLE FOOT COMPONENTS						
27	Base, Removable Assembly ⁵	1		01-5540-99		
11	Screw, Hex Washer Head Tri-Lobe (#12-11 x 7/8")	4		01-6114-03		

*See Elastomer Options

¹ Air Valve Assembly includes item 6 and 9.

² Accu-Flo™ Air Valve Assembly includes items 2 and 13.

³ Air Valve Center Section Assembly includes items 1, 6, 9, 10, 11 and 12.

⁴ Accu-Flo™ Center Section Assembly includes items 1, 2, 3, 4 and 13.

⁵ Removable Base Assembly includes item 11.

All boldface items are primary wear parts. LW0481 Rev. B

ELASTOMER OPTIONS

MATERIAL	DIAPHRAGMS (2)	DIAPHRAGM BACK-UP SEAL (2)	POLY BALL CHECK CARTRIDGE (4)	PVDF BALL CHECK CARTRIDGE (4)	MANIFOLD O-RINGS (4)
PTFE	01-1044-55		01-9189-55	01-9188-55	
Saniflex™		01-1074-56			
Wil-Flex™	01-1044-58		01-9189-58	01-9188-58	02-1200-58-500
PTFE-Encapsulated FKM					02-1200-60-500

LW0481 Rev. B

MAXIMUM TORQUE SPECIFICATIONS

VELOCITY MAXIMUM TORQUE SPECIFICATIONS

Description of Part	Torque
Liquid Chamber – Center Section	6.8 N•m (60 in-lb)
Outer Piston	12.4 N•m (110 in-lb)
Solenoid - Air Valve Assembly (#6)	2.3 N•m (20 in-lb)

WARRANTY

Each and every product manufactured by Wilden Pump & Engineering, LLC is built to meet the highest standards of quality. Every pump is functionally tested to insure integrity of operation. Wilden Pump & Engineering, LLC warrants that pumps, accessories and parts manufactured or supplied by it to be free from defects in material and workmanship for a period of five (5) years from date of installation or six (6) years from date of manufacture, whichever comes first. Failure due to normal wear, misapplication, or abuse is, of course, excluded from this warranty. Since the use of Wilden pumps and parts is beyond our control, we cannot guarantee the suitability of any pump or part for a particular application and Wilden Pump & Engineering, LLC shall not be liable for any consequential damage or expense arising from the use or misuse of its products on any application. Responsibility is limited solely to replacement or repair of defective Wilden Pump & Engineering, LLC. All decisions as to the cause of failure are the sole determination of Wilden Pump & Engineering, LLC. Prior approval must be obtained from Wilden for return of any items for warranty consideration and must be accompanied by the appropriate MSDS for the product(s) involved. A Return Goods Tag, obtained from an authorized Wilden distributor, must be included with the items which must be shipped freight prepaid. The foregoing warranty is exclusive and in lieu of all other warranties expressed or implied (whether written or oral) including all implied warranties of merchantability and fitness for any particular purpose. No distributor or other person is authorized to assume any liability or obligation for Wilden Pump & Engineering, LLC other than expressly provided herein.

WILDEN[®]

22069 VAN BUREN STREET • GRAND TERRACE, CA 92313-5607
(909) 422-1700 • FAX (909) 783-3440
www.wildenpump.com

