

Air Operated Double Diaphragm Pump

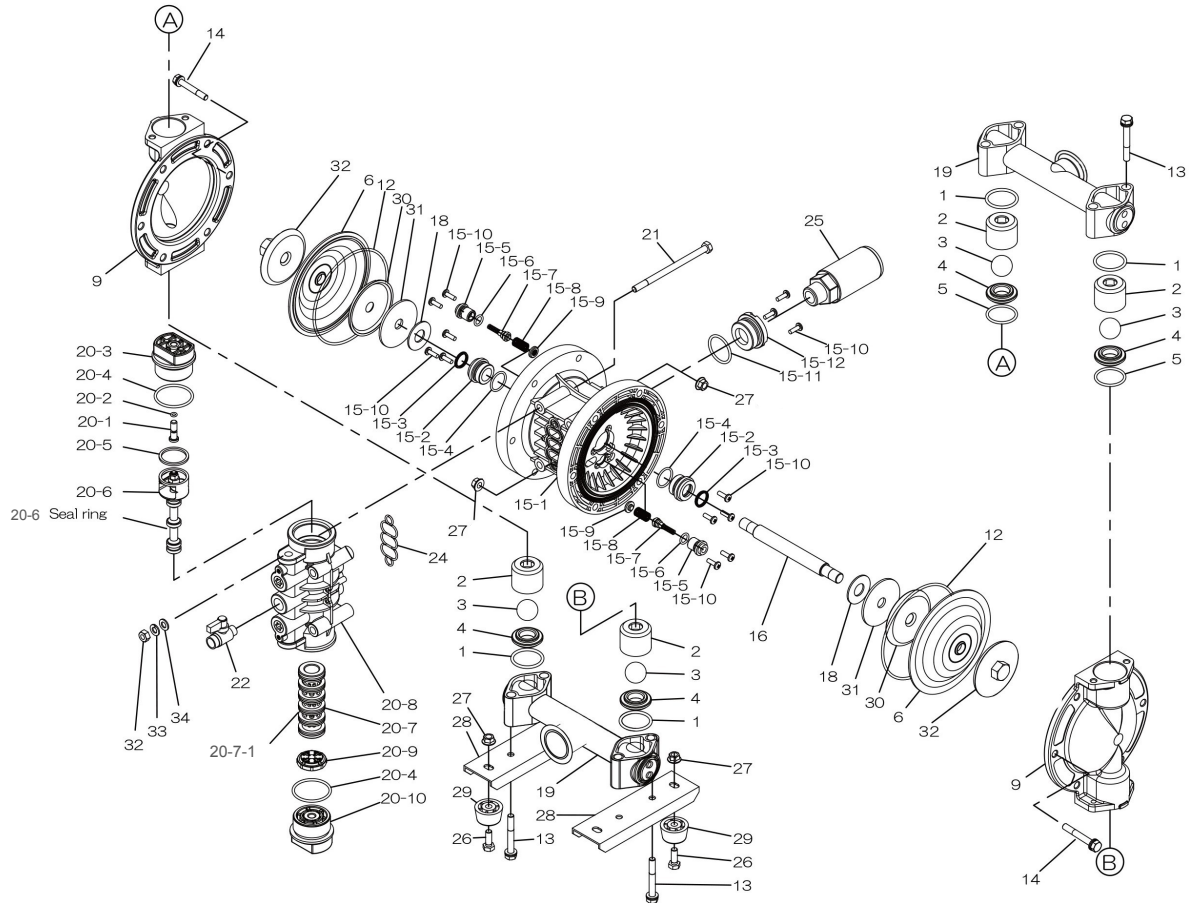

Air Operated Double Diaphragm Pump

Ref. No.	Part No.	Description	QTY	Reorder
1	643044	O-ring	4	
2	711703-EP	Valve Stopper	4	
3	770691	Ball	4	
4	711707-EP	Valve Seat	4	
5	771130	O-ring	2	
6	771260-FDA	Diaphragm	2	
9	711694-EP	Out Chamber	2	
12	640154	O-ring	2	
13	621185	Bolt	8	
13a	631937	Wave Washer	8	
14	621181	Bolt	12	
14a	631937	Wave Washer	12	
<b>15</b>	<b>804647</b>	<b>Body Assembly</b>	<b>1</b>	
15-1	804604	Body	1	
15-2	772931	Throat Bearing	2	
15-3	685414	Packing	2	
15-4	685276	O-ring	2	
15-5	772932	Valve Seat	2	
15-6	640009	O-ring	2	
15-7	802360	Pilot Valve Assembly	2	
15-8	708666	Spring	2	
15-9	772948	Spring Seat	2	
15-10	686030	Tapping Screw	13	
15-11	640132	O-ring	1	
15-12	772933	Bushing	1	
16	710271	Center Rod	1	
18	771054	Cushion	2	
19	831271-TC-EP	Manifold	2	
<b>20</b>	<b>804608</b>	<b>Valve Body Assembly</b>	<b>1</b>	
20-1	772991	Rest Button	1	
20-2	640002	O-ring	1	
20-3	772946	Cap A	1	
20-4	640043	O-ring	2	
20-5	771241	Packing	1	
20-6	802400	C Spool Valve Assy.	1	
20-6 seal	771053	Seal Ring	5	
20-7	804609	Sleeve Assembly	1	
20-7-*1	686029	O-ring	6	
20-8	832903	Valve Body Assembly	1	
20-9	771914	Cushion	1	
20-10	772947	Cap B	1	
21	686031	Bolt	4	
22	684320	Ball Valve	1	
24	772848	Gasket	1	
25	804697	Silencer	1	
26	611148	Bolt	4	
27	686033	Nut	4	
28	709156-XP	Pump Base	2	
29	770551	Cushion	4	
30	716258	Center Disk	2	
31	716259	Washer	2	
32	709151-EP	Center Disk	2	
KIT	K25-ME-FDA	LIQUID SIDE KIT		
KIT	K225-AP	AIR MOTOR KIT		

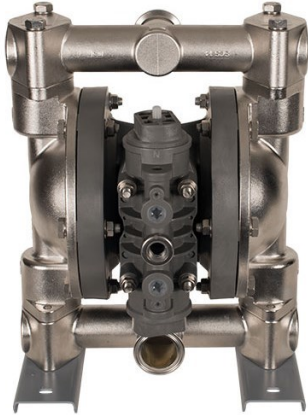
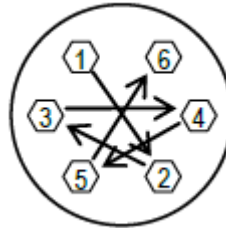

**Tightening torque for center rod and out chambers.**

Center Rod 29 ft-lbf (40 N-m)  
Out Chambers 10 ft-lbf (13 N-m)

**Tightening torque for manifold retainer bolts.**

BSE-FDA 8 ft-lbf (10 N-m)

**General Tools:**

- Socket wrenches - 10mm, 12mm, 13mm, 17mm, 22mm
- Hexagonal box wrench - 5mm
- Open-end wrench - 22mm

**Miscellaneous:**

- Assembly oil - turbine oil non additional class 1 (equivalent to ISO VG32 grade)
- Nuts - M14 x 1.5
- Urea grease grade (NLGI) No. 2
- Lubricants (equivalent to Loctite Anti-Seize 767)

**Customer Notes**

Model #: \_\_\_\_\_  
 Description: \_\_\_\_\_  
 Serial #: \_\_\_\_\_  
 Date Installed: \_\_\_\_\_  
 Department Location: \_\_\_\_\_  
 Tag/Project: \_\_\_\_\_