

Please read and save this Repair Parts Manual. Read this manual and the General Operating Instructions carefully before attempting to assemble, install, operate or maintain the product described. Protect yourself and others by observing all safety information. The Safety Instructions are contained in the General Operating Instructions. Failure to comply with the safety instructions accompanying this product could result in personal injury and/or property damage! Retain instructions for future reference. AMT reserves the right to discontinue any model or change specifications at any time without incurring any obligation.

©2014 American Machine & Tool Co., Inc. of PA, A Subsidiary of The Gorman-Rupp Company, All Rights Reserved.

Periodic maintenance and inspection is required on all pumps to ensure proper operation. Unit must be clear of debris and sediment. Inspect for leaks and loose bolts. Failure to do so voids warranty.

3-Inch Trash Pump

Refer to form 1808-633-00 for General Operating and Safety Instructions.



DESCRIPTION

These trash pumps are high capacity, heavy duty, centrifugal, engine driven, self-priming (to 20 ft. lift) portable units. The pumps are equipped with a precision lapped mechanical seal to reduce leakage, carrying handle and a clog-resistant impeller capable of handling solids up to 1-1/2" diameter (up to 25% by volume). A 3" NPT suction strainer is included. Handles liquids from 40° to 180° F (4° to 82° C). For use with nonflammable liquids compatible with pump component materials.

NOTE: Electric-start models require a 12-volt, 32 amp hour battery (not included).

MAINTENANCE

▲ WARNING

To prevent accidental starting, always remove the spark plug or disconnect and ground the spark plug wire before attempting to service or remove any component.

CLEANING

These units are designed so that for most cleanout or clogging problems it should not be necessary to remove hoses or piping. The suction area and impeller chambers can be reached by removing (2) threaded handles (Ref. No. 22), suction cleanout cover plate (Ref. No. 21) and gasket (Ref. No. 20).

NOTE: When replacing cleanout cover plate, carefully wipe clean all surfaces on which the gasket has contact. Also, make sure the gasket is in position.

MECHANICAL SEAL REPLACEMENT

Refer to figures 1 and 2.

NOTE: Always replace the seal seat (Ref. No. 8), seal cartridge (Ref. N. 9), and shaft sleeve (Ref. No. 10) to ensure proper mating of mechanical seal components!

1. Unthread cap screws (Ref. No. 24) to remove casing (Ref. No. 19) and casing seal (Ref. No. 7) from adapter (Ref. No. 9).
2. Unthread screws (Ref. No. 13) and remove volute (Ref. No. 14) from adapter.
3. Unscrew impeller (Ref. No. 12) from the engine shaft. Remove the impeller shims (Ref. No. 11), shaft sleeve and seal cartridge from engine shaft. Use a rubber mallet or soft block of wood to loosen impeller. Turn counterclockwise.
4. Unthread cap screws (Ref. No. 3) and remove the adapter from the engine mounting face.
5. Push seal seat from the adapter recess with a screwdriver.
6. Clean the adapter recess before inserting a new seal seat.
7. Carefully wipe the polished surface of the new seal seat with a clean cloth.
8. Wet the rubber portion of the seal seat with a light coating of soapy water.
9. Press the new seal seat squarely into the cavity in the adapter. If the seal seat does not press squarely into the cavity, it can be adjusted in place by pushing on it with a piece of pipe. Always use a piece of cardboard between the pipe and the seal seat to avoid scratching the seal seat. (This is a lapped surface and must be handled very carefully).
10. After the seal seat is in place, ensure that it is clean and has not been marred.
11. Using a clean cloth, wipe the shaft and make certain that it is perfectly clean.

12. Secure the adapter on the engine mounting face.

NOTE: Tighten cap screws EVENLY to avoid cracking rabbet on engine mounting face.

13. Apply a light coating of soapy water to the inside rubber portion of seal cartridge and slide onto the shaft sleeve. Slip the shaft sleeve with seal cartridge onto the engine shaft.

IMPORTANT: Before installing new shaft sleeve, apply a bead of non-hardening, pliable sealant (such as Permatex® Form-A-Gasket® No. 2) to motor shaft shoulder.

14. Replace any impeller shim removed in disassembly.
 15. Screw the impeller back in place tightening until it is seated against shims and shaft sleeve.
 16. Remount volute with fasteners.
 17. Refer to section entitled SHIM ADJUSTMENT at this time if shaft sleeve or any other parts listed therein have been replaced.
 18. Inspect position of flapper valve assembly (Ref. No.15) to ensure proper movement and seating.
 19. Replace o-ring seal on volute rabbet.
- NOTE:** Always inspect o-ring seals. Replace when cracked or worn. Wet o-ring with soapy water for ease of assembly.
20. Remount casing.
 21. Remount any other parts and reconnect spark plug wire. Pump should now run with renewed original performance.

SHIM ADJUSTMENT

1. When installing a replacement impeller, engine, shaft sleeve, adapter or volute, it may be necessary to vary the number of impeller shims (Ref. No. 11) that will be required. This is easily done by adding one 0.010" shim more than was removed and reassembling pump as described in Mechanical Seal Replacement section.
2. Ensure that volute (Ref. No. 14) and adapter (Ref. No. 4) are fitted firmly (check fastener Ref. Nos. 3 & 13). Remove spark plug wire from engine and turn engine over by pulling the recoil starter. If engine does not run freely, disassemble pump and remove one shim.
3. Proper running clearance is 0.010".
4. Follow the above procedure until proper clearance is obtained. This will ensure maximum performance.

3-Inch Trash Pump

IMPELLER AND WEARPLATE REPLACEMENT

Impeller (Ref. No. 12), volute/wearplate (Ref. No. 14) and rear wearplate (Ref. No. 5) are subject to wear only by abrasive sand or sediment laden liquids. If badly worn, all these parts can be replaced easily and the pump thus restored to full efficiency.

NOTE: When the clearance between the impeller and the volute/wearplate exceeds 1/16" at the face of the impeller or 1/8" on the outside diameter of the impeller, it may be necessary to take corrective action. The increased clearance can cause lengthened priming and decreased capacity to your unit. If performance is satisfactory for your application, it is recommended that no corrective maintenance be performed regardless of what clearances on your unit may have developed. This is because increased clearances in themselves are not generally harmful to your pump. Normally, new pump clearances can be restored by simply shimming behind the impeller. (Add shim washers Ref. No. 11). If the impeller is badly worn, it is recommended that the impeller be replaced. This is usually all that is required since only on abrasive surfaces does the cast iron wearplate show deterioration. Occasionally a stone or hard object might get caught in the impeller and cause damage to the volute/cutwater. In these cases follow the instructions below for replacement and refer to Figure 1.

1. Disassemble pump for access as described in Mechanical Seal Replacement, steps 1 and 2.
 2. Replace parts as necessary.
- NOTE:** When replacing volute/wearplate, attach flapper valve assembly (Ref. No. 15) to the new volute with fastener (Ref. No. 16).
3. To replace rear wearplate (Ref. No. 5), remove fasteners (Ref. No. 6) after impeller has been removed.

NOTE: Before Installing new parts, clean all mating surfaces thoroughly.

SUCTION FLANGE REPLACEMENT

1. Unthread the four screws on the suction flange (Ref. No. 28).
2. Remove the old gasket.
3. Replace the gasket. Gasket must be installed between suction flange and casing for proper seal and priming.
4. Install new suction flange and thread the four bolts to the casing. Tighten the bolts in an alternating pattern to avoid pinching

DISCHARGE FLANGE REPLACEMENT

1. Unthread the four screws on the discharge flange (Ref. No. 17).
2. Remove the old gasket.
3. Replace the gasket. Gasket must be installed between discharge flange and casing for proper seal.
4. Install new discharge flange and thread the four bolts to the casing. Tighten the bolts in an alternating pattern to avoid pinching

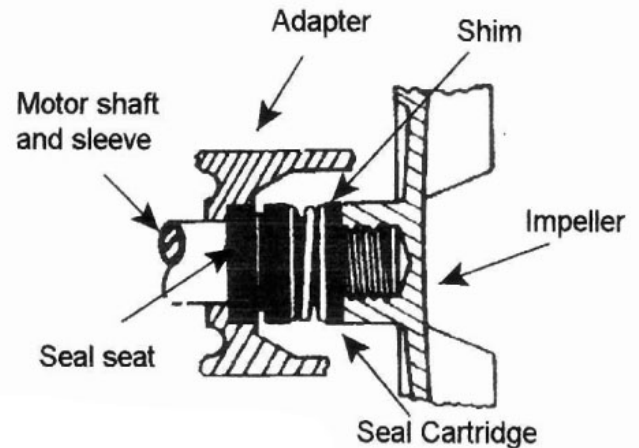

Figure 1 - Mechanical Seal Replacement

3-Inch Trash Pump

For Repair Parts contact dealer where pump was purchased.

Please provide following information:

-Model Number

-Serial Number (if any)

Part description and number as shown in parts list

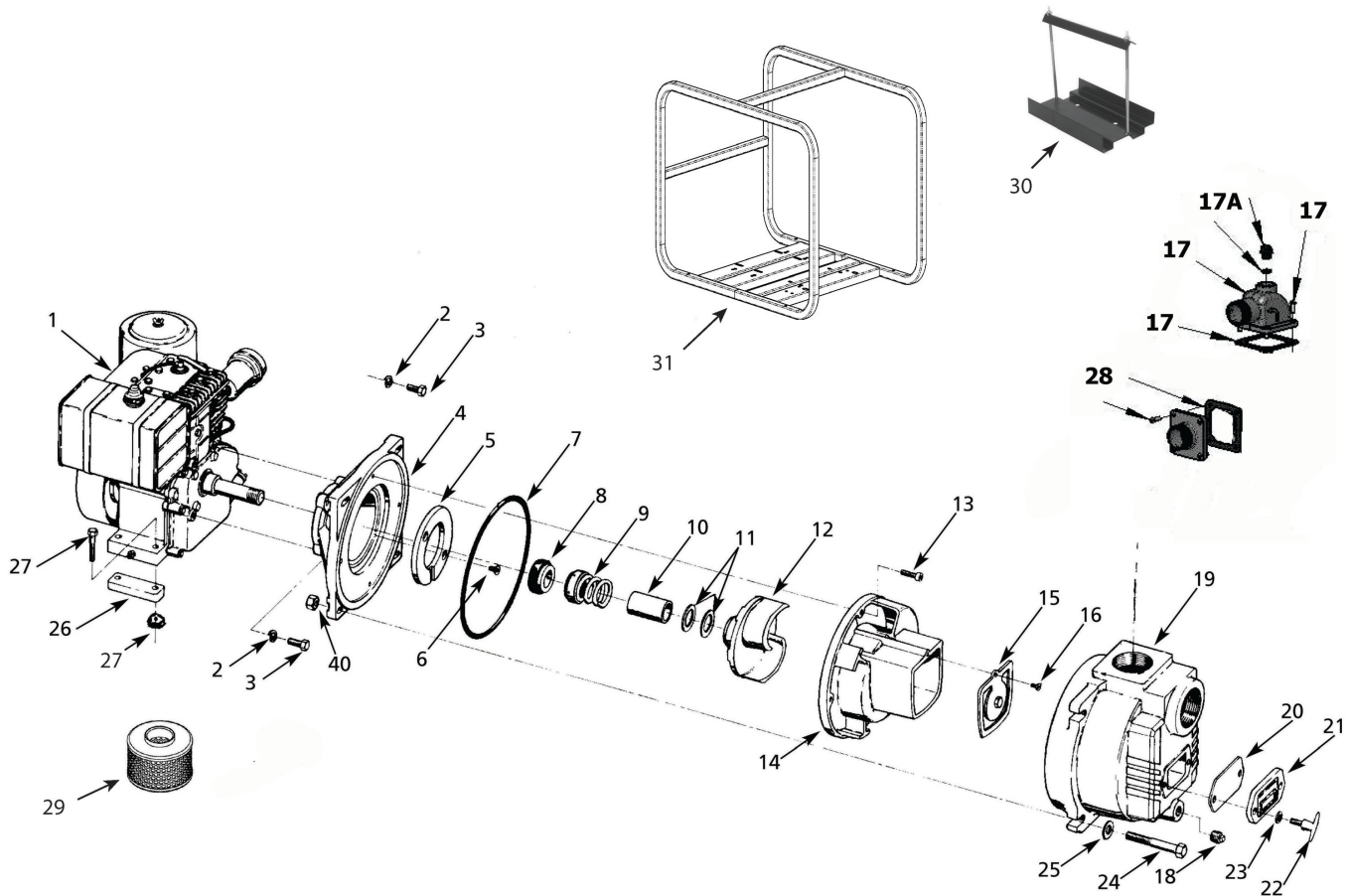

Figure 2 - Repair Parts Illustrations

Order Online: www.PumpCatalog.com

Repair Parts List

Ref No.	Description	Part Number	Qty
1	Engine 3941-96 B&S 8 HP	1639-024-00	1
	Engine 3943-96 Honda 9 HP	1639-026-00	1
	Engine 3944-96 Honda 9 HP	1639-028-00	1
	Engine 3946-96 B&S 8 HP E-Start	1639-022-00	1
	Engine 3942-D6 10 HP Diesel	Discontinued	1
2	Lock Washer	*	4
3	Hex Head Screw	*	4
4	Adapter	2184-001-01	1
5	Wearplate	2182-004-01	1
6	Flat Head Screw, SS	1741-000-00	2
7	O-Ring	Incl. w/ Ref KIT	
8 & 9	Seal Assembly - Viton/Silicon Carbide	1640-167-90 & Incl. w/ Ref KIT	1
10	Shaft Sleeve	1555-140-03	1
11	Impeller Shim Package	1656-000-90	1
12	Impeller	3945-012-03	2
13	Hex Head Screw SS	*	1
14	Volute	2184-002-01	1
15	Flapper Valve Assembly (includes Ref. No. 16)	3590-070-90 & Incl. w/ Ref KIT	1
16	Flat Head Screw SS	*	1
17	3" NPT Male Discharge Flange Kit (includes Flange, 4 Bolts and Gasket)	3941-080-90	1
17A	Fill Plug and O-Ring kit	3SXB-170-90	1
18	3/4" NPT Pipe Plug	*	1
19	Casing	2113-001-02	1
20	Cleanout Gasket	Incl. w/ Ref KIT	1
21	Cleanout Plate	2115-002-01	
22	Cleanout Handle	1601-000-00	2
23	Flat Washer	*	2
24	Hex Head Screw	*	4
25	Flat Washer	*	8
26	Raising Block	1990-021-00	2
27	Hex Head Screw and Nut	*	4
28	3" NPT Male Suction Flange Kit (includes Flange, 4 Bolts and Gasket)	3941-050-90	1
29	3" NPT Suction Strainer	C520-999-90	1
30	(◆) Battery Tray Kit Includes: 12" Battery cable (not shown) 30" Battery Cable (not shown)	1696-BAT-K0	1
31	Roll Cage	1696-100-K0	1
N/S	Replacement Flange Gasket Kit (2 per) (for Ref. Nos. 17 and 28)	3941-301-90	1
KIT	Complete Seal Kit (includes Ref. Nos. 7, 8, 9, 10, 15 and 20)	S394-BSC-K0	1

(*) Standard hardware item, available locally.

(◆) Electric start models only

N/S Not Shown

Order Online: www.PumpCatalog.com

Note: Wheel Kit available separately; order model C402-90



American Machine & Tool Co., Inc. of PA
(herein "AMT")
400 Spring Street
Royersford, PA 19468
Phone: (610) 948-3800
Fax: (610) 948-5300
www.amtpump.com



General Information

SALES POLICY: AMT products are sold through our established Distributors. We do not sell direct to the consumer or organization not entitled to trade recognition. Therefore, possession of our catalogs and/or price list(s) does not infer an offer to sell.

MINIMUM ORDER: We appreciate your order, however, all orders are subject to a minimum \$35.00 net invoice charge (excluding freight). This applies to all pump and parts purchase orders.

PRICES: Prices are subject to change without notice. All orders accepted are subject to prices in effect at time of shipment.

PAYMENT TERMS: Terms, upon establishment of credit, are Net 30 days. Past due accounts may be subject to a service charge of 1.5% per month. Domestic or assignable letter of credit is required for all export trade.

PAST DUE ACCOUNTS: AMT reserves the right to withhold open account shipments on any past due account. Invoices are considered past due after thirty (30) days. In the interest of sound business, all orders are subject to approval of the Credit Department.

SHIPPING INSTRUCTIONS: All shipments will be made F.O.B. the factory. Where instructions for shipment do not appear on the order, the shipment will be made according to our best judgment. Full risk of loss (including transportation delays and losses) shall pass to the customer upon delivery of the products to the carrier at the F.O.B. point. When loss or delay occurs, primary responsibility for tracing rests with the customer. When there is LOSS or APPARENT VISIBLE DAMAGE to a shipment, when tendered for delivery, *DO NOT* give the carrier a clear receipt. Note such damage on the carrier's delivery receipt and *HAVE THE DRIVER SIGN THE RECEIPT.*

PRODUCT REVISIONS: AMT reserves the right to discontinue, change or improve its products or any portions thereof without being obligated to provide such a change or improvement for units sold and/or shipped prior to such a change or improvement.

LEAD TIME: Products designated "Quick Ship Product", also referred to as "QSP" will normally be shipped within 24 hours of receipt of a non-cancellable purchase order. Only limited quantities of "QSP" pumps are available.

STANDARD LEAD TIME: Lead time is two weeks for all non "QSP" product. AMT reserves the right to revise lead times as required due to availability of materials and all other causes beyond our control.

VIP SHIPMENT: Select AMT and IPT branded pumps are available for next day shipment for non-QSP (Quick Ship Products) items and subjected to a specific model surcharge per unit noted in the respective price book. Requires calling for availability, confirmation and a non-cancellable purchase order or credit card payment prior to shipment. The expedited shipping charges are an additional cost added separately from the VIP charges per item. AMT reserves the right to revise lead times as required due to availability of materials and all other causes beyond our control. QSP quantities are limited as determined by AMT.

ALL purchase orders must be submitted via hard copy sent to AMT customer service department by fax, EDI or e-mail.

RETURN GOODS POLICY: Goods shall not be returned without a return goods authorization number (RGA) issued by AMT customer service. The RGA number must be listed on the packing list. Only current model and part numbers with a valid date code may be returned (within one year from date of purchase). **A 20% restocking and packaging charge will apply to all returns. All shipping charges must be pre-paid. No exceptions.**

ORDER CHANGES BY CUSTOMER: Orders in process may not be changed except with written consent and may be subject to special charges.

12 Month Limited Warranty

EXTENT AND DURATION OF LIMITED WARRANTY

Coverage: American Machine & Tool Company (herein "AMT") or IPT Pumps by Gorman-Rupp (herein "IPT") or Gorman-Rupp Industries Division of The Gorman-Rupp Company, Patterson, or the Gorman-Rupp Company (herein referred to as "G-R Unit") each individually warrants that its products and parts shall be free from defects in material and workmanship for twelve (12) months from the date of purchase by the original end user when installation is made and maintenance is performed in accordance with G-R Unit's recommendations. Wear and tear resulting from use and items normally consumed in use are not covered.

EXCEPTIONS

(A) This Limited Warranty shall not apply to mechanical seals in AMT or IPT pumps and the following products and parts: engines, motors, trade accessories and all other products, components, parts and materials not manufactured by the G-R Units. These items may, however, be covered by the warranties of their respective manufacturers. (B) This warranty does not extend to or apply to any unit which has been repaired or altered at any place other than by a G-R Unit, or by persons not expressly approved by a G-R Unit to make repairs or alterations, nor to any unit the serial number, model number or identification of which has been removed, defaced or altered. (C) This warranty does not extend to any product manufactured by a G-R Unit, which has been subjected to mis-use, neglect, accident, improper installation, or use in violation of instructions furnished by a G-R Unit. (D) Pump Kits: This warranty does not extend to any product sold by a G-R Unit unassembled as a Pump Kit. Pump Kits are warranted against defects in material and workmanship for 60 days from the date of shipment from a G-R Unit. Any Pump Kit parts deemed defective by a G-R Unit will be replaced free of charge within 60 days of shipment. Pump Kits are not returnable for credit.

LIMITATIONS

THE G-R UNITS' SOLE AND EXCLUSIVE WARRANTY WITH RESPECT TO THEIR PRODUCTS AND PARTS IS THIS LIMITED WARRANTY. THIS LIMITED WARRANTY IS IN LIEU OF ALL OTHER EXPRESS AND/OR IMPLIED WARRANTIES, INCLUDING IMPLIED WARRANTIES OF MERCHANTABILITY AND FITNESS FOR PARTICULAR PURPOSE.

EXCLUSIVE REMEDY AND DAMAGES

The sole and exclusive remedy for breach of this Warranty by a G-R Unit and the entire extent of its liability for such breach or for damages arising from the use of the products and parts covered under this Limited Warranty, shall be as follows:

- Repair or Replacement:** If inspection shows that any G-R Unit product or part covered under this Limited Warranty is defective in materials or workmanship, the G-R Unit shall repair or replace the defective or non-conforming product or part without charge, whichever the G-R Unit chooses. You must have properly maintained and used the product or part claimed to be defective in accordance with the maintenance schedule or manual, which comes with the product. No allowance will be made for labor, installation, removal, transportation or other charges incurred by you in connection with such repair or replacement.
- To obtain the above remedy:
 - Immediately notify the G-R Unit upon discovery of the claimed defect in materials or workmanship and provide the serial number or date code of the product and/or part(s) or provide the G-R Unit with the invoice or bill of sale referencing the product by no later than the expiration date of the warranty period.
 - The G-R Unit will advise whether inspection will be necessary and how whether repair or replacement will be made. If inspection by the G-R Unit is necessary, the pump or defective part must be sent freight pre-paid to the G-R Unit. Return shipment will be F.O.B. the G-R Unit's plant.
 - Return Goods Authorization Requirement:** No product will be accepted for return or replacement without the prior written authorization of the G-R Unit. Upon such authorization, and in accordance with instructions from the G-R Unit, the product will be returned to the G-R Unit, shipping charges prepaid by the Buyer.
- Damages:** The G-R Unit's liability for damages for breach of this Limited Warranty shall not exceed the amount of the purchase price of the product or part(s) in respect to which Such damages are claimed. **IN NO EVENT SHALL THE G-R UNITS BE LIABLE FOR INCIDENTAL, CONSEQUENTIAL OR SPECIAL DAMAGES FOR BREACH OF THIS LIMITED WARRANTY.**

Some states do not allow the exclusion or limitation of incidental or consequential damages, so the above limitation or exclusion may not apply to you. This Limited Warranty gives you specific legal rights, and you may also have other rights, which vary from state to state.



A Gorman-Rupp Company



BY
GORMAN-RUPP®

www.amtpump.com