

Please read and save this Repair Parts Manual. Read this manual and the General Operating Instructions carefully before attempting to assemble, install, operate or maintain the product described. Protect yourself and others by observing all safety information. The Safety Instructions are contained in the General Operating Instructions. Failure to comply with the safety instructions accompanying this product could result in personal injury and/or property damage! Retain instructions for future reference. AMT reserves the right to discontinue any model or change specifications at any time without incurring any obligation.

©2013 American Machine & Tool Co., Inc. of PA, A Subsidiary of The Gorman-Rupp Company, All Rights Reserved.

Periodic maintenance and inspection is required on all pumps to ensure proper operation. Unit must be clear of debris and sediment. Inspect for leaks and loose bolts. Failure to do so voids warranty.

3/4-Inch Bronze Centrifugal Pump



Refer to pump manual 1808-634-00 for General Operating and Safety Instructions.

DESCRIPTION

This compact utility pump is designed for a wide range of dewatering and liquid transfer applications including marine and aquaculture. Handles liquids from 40° F to 180° F (4° to 82° C). This is a manual unit, no controls are supplied. For use with nonflammable, non-abrasive liquids compatible with pump component materials.

MODELS 4850-97 & 4851-97

These pumps self-prime (to 4-1/2 ft. lift with pump filled) and can be used as a bilge pump for small boats or a water system pump in campers and trailers. The pump can be mounted up to a 45° angle or on a thru-hull fitting and seacock for applications requiring water aboard to be pumped overboard.

GENERAL SAFETY INFORMATION (FOR 12 VDC UNITS ONLY)

- General connection information to a 12 VDC battery:
 - Connect POSITIVE or PLUS(+) lead from the pump to battery first. POSITIVE lead of pump is red.
 - Connect NEGATIVE or MINUS(-) lead last. NEGATIVE lead of pump is black.
 - When DISCONNECTING – Disconnect NEGATIVE (-) lead first, then disconnect the POSITIVE (+) lead from the battery.
- Specific connection information:
 - If pump is installed in car or truck and the installed car or truck battery is being used:
 - Connect POSITIVE or PLUS (+) lead from the pump to battery first. POSITIVE lead of pump is red.
 - Then connect NEGATIVE or MINUS (-) lead to a ground away from the battery, such as the metal of the car. Always connect NEGATIVE (-) last. NEGATIVE lead of pump is black.
 - When DISCONNECTING – Disconnect the NEGATIVE (-) lead from the grounded location, then disconnect the POSITIVE (+) lead from the battery.
 - Pump is installed in recreational vehicle (RV), boat, motor home, etc.
 - Follow general connection information.
 - If possible, connect NEGATIVE (-) lead of the pump to negative wiring terminal strip or other negative common point of the battery (away from the battery) if so equipped.
- When attaching pump leads to battery terminals, be sure that the area (bilge of a boat, for instance) is adequately ventilated to prevent an explosion or fire from explosive or flammable vapors that may be present.

▲ WARNING

Batteries emit hydrogen gas which is explosive. Avoid smoking, sparks or open flame anywhere in the vicinity of the battery.

Explosion from battery can cause blindness. Shield eyes when working near any battery.

Batteries contain sulfuric acid. In case of contact with eyes, skin or clothing, flush immediately with large amount of water, get medical attention.

- When using leads longer than those supplied, be sure the wire is adequately sized.

▲ WARNING

Do not add acid or electrolyte to battery being used – add only water. Consult the battery manufacturers for any additional safety instructions.

INSTALLATION (FOR 12 VDC UNITS ONLY) WIRING & ROTATION

Connect black wire to NEGATIVE (-) terminal of battery. The orange wire with the fuse holder should run to an overload protected switch or circuit breaker, with a wire from switch or breaker to POSITIVE (+) terminal of battery. Electrical circuit must be independent of all other accessories. To prolong motor life, install pump so normal motor rotation is clockwise (See Figure 1). Use proper wire size as determined by Wire Table (See Figure 1). The proper fuse has been included in the fuse holder. Should this fuse blow, replace with the same size fuse after determining reason for blown fuse.

NOTE: No warranty consideration will be given to pumps that are returned without the properly sized fuse and fuse holder supplied with the pump.

Figure 1 – Wiring Diagram

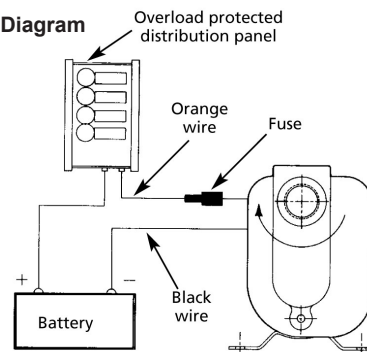

Connection Length Between Battery and Motor		12V
1-10ft		12 gauge wire
11-20		10 gauge wire
21-30		8 gauge wire

If unsure about the above information or the wiring diagrams, consult an electrician familiar with motor wiring.

AMP DRAW AND FUSE SIZES (FOR 12VDC UNITS ONLY)	
AMP draw (approx.)	10.5
Fuse size	15

3/4-Inch Bronze Centrifugal Pump

MAINTENANCE

▲ WARNING

Disconnect from power source before servicing or inspecting pump for any reason. Failure to do so could result in fatal electrical shock!

MECHANICAL SEAL REPLACEMENT

Refer to Figures 2, and 3

IMPORTANT: Always replace both seal seat (Ref. No. 7) and seal head (Ref. No. 6) to ensure proper matching of components!

1. Unthread fasteners (Ref. No. 8), remove casing (Ref. No. 12) and casing seal (Ref. No. 11).
2. Unscrew fastener (Ref. No. 10) from impeller (Ref. No. 9) and remove impeller.
3. Remove fasteners (Ref. No. 2) and washers (Ref. No. 3) and remove adapter (Ref. No. 5).
4. Lay adapter face down on a flat stable surface and press seal head from adapter.
5. Pry seal seat from rear of impeller with a screwdriver or other suitable means.
6. Clean recess in adapter for seal head and recess in impeller for seal seat before inserting any new parts.
7. Inspect polished face of seal seat and head to be sure each piece is clean and not marred.
8. Press new head into recess in adapter. A sealing compound (such as silicon or Permatex) may be used to assure a water tight fit on outside of head.
9. Press seal seat squarely into cavity in impeller (See Figure 3). If seal seat does not press squarely into cavity, it can be adjusted in place by pushing on it with a piece of pipe. Always use a piece of cardboard between pipe and seal seat to avoid scratching face of seal seat. This is a lapped surface and must be handled very carefully.
10. After seal seat is in place, check that it is clean and has not been scratched or cracked.
11. Mount adapter on motor mounting face.
12. Replace impeller providing 0.020" clearance between adapter and impeller (see figure 3), then tighten impeller fastener.
13. Place casing seal on adapter and replace casing. Replace and tighten fasteners.
14. Before operating make certain impeller turns freely and is not rubbing casing.

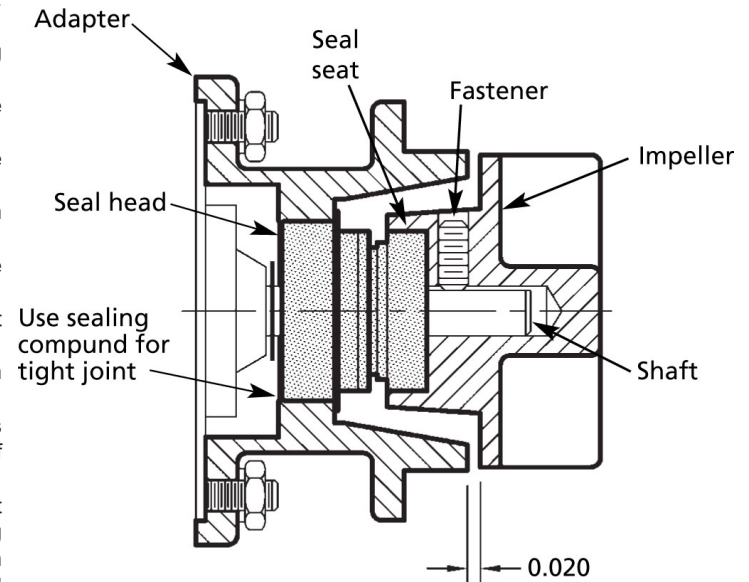

Figure 2

3/4-Inch Bronze Centrifugal Pump

For Repair Parts contact dealer where pump was purchased.

Please provide following information:

-Model Number

-Serial Number (if any)

Part description and number as shown in parts list

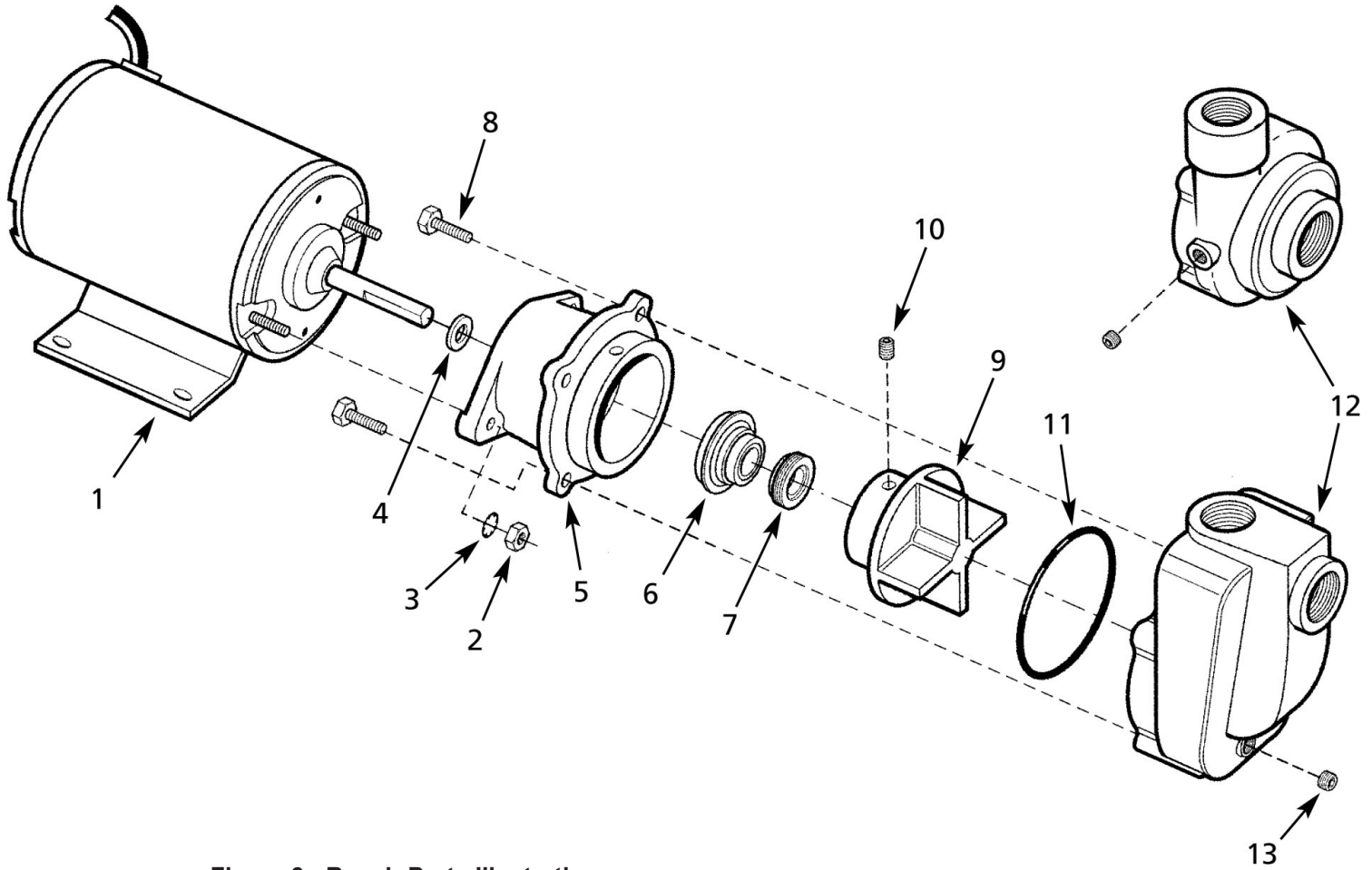

Figure 3 - Repair Parts Illustrations

Repair Parts List

Ref No.	Description	Part Number for Models				Qty
		4850-97	4851-97	4860-97	4861-97	
		Self-prime 12 VDC	Self-prime 115 VAC	Non-prime 12 VDC	Non-prime 115 VAC	
1	Motor	1626-023-00	N/A	N/A	1626-028-00	1
2	Fastener	*	*	*	*	2
3	Washer	*	*	*	*	2
4	Flinger washer	4850-300-00	4850-300-00	4850-300-00	4850-300-00	1
5	Adapter	4851-030-09	4851-030-09	4851-030-09	4851-030-09	1
6 & 7	† Shaft seal assembly, Buna-N	1641-051-90	1641-051-90	1641-051-90	1641-051-90	1
8	Fastener	*	*	*	*	4
9	Impeller	4850-010-09	4850-010-09	4850-010-09	4850-010-09	1
10	Fastener	*	*	*	*	1
11	Casing seal, Buna-N	1567-002-00	1567-002-00	1567-002-00	1567-002-00	1
12	Casing	4850-001-09	4850-001-09	4860-001-09	4860-001-09	1
13	Pipe plug	*	*	*	*	1

(*) Standard hardware item, available locally.

(†) Seal head and seat available as set only.



American Machine & Tool Co., Inc. of PA
(herein "AMT")
400 Spring Street
Royersford, PA 19468
Phone: (610) 948-3800
Fax: (610) 948-5300
www.amtpump.com



General Information

SALES POLICY: AMT products are sold through our established Distributors. We do not sell direct to the consumer or organization not entitled to trade recognition. Therefore, possession of our catalogs and/or price list(s) does not infer an offer to sell.

MINIMUM ORDER: We appreciate your order, however, all orders are subject to a minimum \$35.00 net invoice charge (excluding freight). This applies to all pump and parts purchase orders.

PRICES: Prices are subject to change without notice. All orders accepted are subject to prices in effect at time of shipment.

PAYMENT TERMS: Terms, upon establishment of credit, are Net 30 days. Past due accounts may be subject to a service charge of 1.5% per month. Domestic or assignable letter of credit is required for all export trade.

PAST DUE ACCOUNTS: AMT reserves the right to withhold open account shipments on any past due account. Invoices are considered past due after thirty (30) days. In the interest of sound business, all orders are subject to approval of the Credit Department.

SHIPPING INSTRUCTIONS: All shipments will be made F.O.B. the factory. Where instructions for shipment do not appear on the order, the shipment will be made according to our best judgment. Full risk of loss (including transportation delays and losses) shall pass to the customer upon delivery of the products to the carrier at the F.O.B. point. When loss or delay occurs, primary responsibility for tracing rests with the customer. When there is LOSS or APPARENT VISIBLE DAMAGE to a shipment, when tendered for delivery, *DO NOT* give the carrier a clear receipt. Note such damage on the carrier's delivery receipt and *HAVE THE DRIVER SIGN THE RECEIPT.*

PRODUCT REVISIONS: AMT reserves the right to discontinue, change or improve its products or any portions thereof without being obligated to provide such a change or improvement for units sold and/or shipped prior to such a change or improvement.

LEAD TIME: Products designated "Quick Ship Product", also referred to as "QSP" will normally be shipped within 24 hours of receipt of a non-cancellable purchase order. Only limited quantities of "QSP" pumps are available.

STANDARD LEAD TIME: Lead time is two weeks for all non "QSP" product. AMT reserves the right to revise lead times as required due to availability of materials and all other causes beyond our control.

VIP SHIPMENT: Select AMT and IPT branded pumps are available for next day shipment for non-QSP (Quick Ship Products) items and subjected to a specific model surcharge per unit noted in the respective price book. Requires calling for availability, confirmation and a non-cancellable purchase order or credit card payment prior to shipment. The expedited shipping charges are an additional cost added separately from the VIP charges per item. AMT reserves the right to revise lead times as required due to availability of materials and all other causes beyond our control. QSP quantities are limited as determined by AMT.

ALL purchase orders must be submitted via hard copy sent to AMT customer service department by fax, EDI or e-mail.

RETURN GOODS POLICY: Goods shall not be returned without a return goods authorization number (RGA) issued by AMT customer service. The RGA number must be listed on the packing list. Only current model and part numbers with a valid date code may be returned (within one year from date of purchase). **A 20% restocking and packaging charge will apply to all returns. All shipping charges must be pre-paid. No exceptions.**

ORDER CHANGES BY CUSTOMER: Orders in process may not be changed except with written consent and may be subject to special charges.

12 Month Limited Warranty

EXTENT AND DURATION OF LIMITED WARRANTY

Coverage: American Machine & Tool Company (herein "AMT") or IPT Pumps by Gorman-Rupp (herein "IPT") or Gorman-Rupp Industries Division of The Gorman-Rupp Company, Patterson, or the Gorman-Rupp Company (herein referred to as "G-R Unit") each individually warrants that its products and parts shall be free from defects in material and workmanship for twelve (12) months from the date of purchase by the original end user when installation is made and maintenance is performed in accordance with G-R Unit's recommendations. Wear and tear resulting from use and items normally consumed in use are not covered.

EXCEPTIONS

(A) This Limited Warranty shall not apply to mechanical seals in AMT or IPT pumps and the following products and parts: engines, motors, trade accessories and all other products, components, parts and materials not manufactured by the G-R Units. These items may, however, be covered by the warranties of their respective manufacturers. (B) This warranty does not extend to or apply to any unit which has been repaired or altered at any place other than by a G-R Unit, or by persons not expressly approved by a G-R Unit to make repairs or alterations, nor to any unit the serial number, model number or identification of which has been removed, defaced or altered. (C) This warranty does not extend to any product manufactured by a G-R Unit, which has been subjected to mis-use, neglect, accident, improper installation, or use in violation of instructions furnished by a G-R Unit. (D) Pump Kits: This warranty does not extend to any product sold by a G-R Unit unassembled as a Pump Kit. Pump Kits are warranted against defects in material and workmanship for 60 days from the date of shipment from a G-R Unit. Any Pump Kit parts deemed defective by a G-R Unit will be replaced free of charge within 60 days of shipment. Pump Kits are not returnable for credit.

LIMITATIONS

THE G-R UNITS' SOLE AND EXCLUSIVE WARRANTY WITH RESPECT TO THEIR PRODUCTS AND PARTS IS THIS LIMITED WARRANTY. THIS LIMITED WARRANTY IS IN LIEU OF ALL OTHER EXPRESS AND/OR IMPLIED WARRANTIES, INCLUDING IMPLIED WARRANTIES OF MERCHANTABILITY AND FITNESS FOR PARTICULAR PURPOSE.

EXCLUSIVE REMEDY AND DAMAGES

The sole and exclusive remedy for breach of this Warranty by a G-R Unit and the entire extent of its liability for such breach or for damages arising from the use of the products and parts covered under this Limited Warranty, shall be as follows:

- Repair or Replacement:** If inspection shows that any G-R Unit product or part covered under this Limited Warranty is defective in materials or workmanship, the G-R Unit shall repair or replace the defective or non-conforming product or part without charge, whichever the G-R Unit chooses. You must have properly maintained and used the product or part claimed to be defective in accordance with the maintenance schedule or manual, which comes with the product. No allowance will be made for labor, installation, removal, transportation or other charges incurred by you in connection with such repair or replacement.
- To obtain the above remedy:
 - Immediately notify the G-R Unit upon discovery of the claimed defect in materials or workmanship and provide the serial number or date code of the product and/or part(s) or provide the G-R Unit with the invoice or bill of sale referencing the product by no later than the expiration date of the warranty period.
 - The G-R Unit will advise whether inspection will be necessary and how whether repair or replacement will be made. If inspection by the G-R Unit is necessary, the pump or defective part must be sent freight pre-paid to the G-R Unit. Return shipment will be F.O.B. the G-R Unit's plant.
 - Return Goods Authorization Requirement:** No product will be accepted for return or replacement without the prior written authorization of the G-R Unit. Upon such authorization, and in accordance with instructions from the G-R Unit, the product will be returned to the G-R Unit, shipping charges prepaid by the Buyer.
- Damages:** The G-R Unit's liability for damages for breach of this Limited Warranty shall not exceed the amount of the purchase price of the product or part(s) in respect to which Such damages are claimed. **IN NO EVENT SHALL THE G-R UNITS BE LIABLE FOR INCIDENTAL, CONSEQUENTIAL OR SPECIAL DAMAGES FOR BREACH OF THIS LIMITED WARRANTY.**

Some states do not allow the exclusion or limitation of incidental or consequential damages, so the above limitation or exclusion may not apply to you. This Limited Warranty gives you specific legal rights, and you may also have other rights, which vary from state to state.



A Gorman-Rupp Company



BY

GORMAN-RUPP®

www.amtpump.com