

# **BALDOR® • RELIANCE**

## **Product Information Packet**

### **CEM7170T-I**

**10//7.5HP,1765//1465RPM,3PH,60//50HZ,215**

Part Detail							
Revision:	K	Status:	PRD/A	Change #:		Proprietary:	No
Type:	AC	Prod. Type:	0750M	Elec. Spec:	07WGX598	CD Diagram:	CD0005
Enclosure:	XPFC	Mfg Plant:		Mech. Spec:	07J232	Layout:	07LYJ232
Frame:	215TC	Mounting:	F1	Poles:	04	Created Date:	08-04-2010
Base:	RG	Rotation:	R	Insulation:	F	Eff. Date:	08-20-2015
Leads:	9#14					Replaced By:	
Literature:		Elec. Diagram:					

Nameplate NP0977XPSLEV											
NO.							CC	010A			
SER.							TEMP CODE	T3C			
SPEC.	07J232X598G2										
CAT.NO.	CEM7170T-I										
HP	10//7.5										
VOLTS	230/460//190/380										
AMPS	24.6/12.3//23/11.5										
RPM	1765//1465						MOTOR WEIGHT	252			
HERTZ	60//50			PH	3	CL	F	DE BRG	6307		
SER.F.	1.15			DES	A	CODE	J	ODE BRG	6206		
FRAME	215TC			GREASE	POLYREX EM						
RATING	40C AMB-CONT 55C AMB AT 1.0 SF										
USABLE AT 208V							NEMA-NOM-EFF	92.4		PF	81
	NEMA MG-1 PT 5,IP55										

Parts List		
Part Number	Description	Quantity
SA201088	SA 07J232X598G2	1.000 EA
RA188393	RA 07J232X598G2	1.000 EA
37FN3002B01	EXFN, PLASTIC, 7.50 OD, 1.155 ID	1.000 EA
HA3210E08	.250X 7/8 PIN 312-57	1.000 EA
HW3201A05	3/8-16 EYEBOLT	1.000 EA
07CB1000A01	CONDUIT BOX MACH	1.000 EA
10XN3118A16	5/16-18X1 HEX HD CAP	4.000 EA
HW1001A31	LOCKWASHER 5/16, ZINC PLT.591 OD, .319 I	4.000 EA
11XW1032G06	10-32 X .38, TAPTITE II, HEX WSHR SLTD U	1.000 EA
WD1000B17	T&B CX35TN TERMINAL	1.000 EA
07EP1707A17	FREP XP GR C W/DRAINS, GRSRS	1.000 EA
HW4500A19	1/4-28X1/4 SLOTTED PLUG F/S	2.000 EA
HW4506A02	BREATHER/DRAIN-EXP PROOF-.125-27 NPTF AI	1.000 EA
HW3022E05	.125 DIA X .500 ROLLED SPRING PIN	1.000 EA
10XN3816K28	3/8-16 X 1.75 HEX HD CAP SCREW, GRADE 5	4.000 EA
HW1001A38	LOCKWASHER 3/8, ZINC PLT .688 OD, .382 I	4.000 EA
HW5100A06	W2420-025 WVY WSHR (WB)	1.000 EA
07EP1708A12	PUEP 213-5TC 307M "DRILL RIG DUTY" SLING	1.000 EA
HW4500A19	1/4-28X1/4 SLOTTED PLUG F/S	2.000 EA
HW4506A02	BREATHER/DRAIN-EXP PROOF-.125-27 NPTF AI	1.000 EA
HW3022E05	.125 DIA X .500 ROLLED SPRING PIN	1.000 EA
10XN3816K28	3/8-16 X 1.75 HEX HD CAP SCREW, GRADE 5	4.000 EA
HW1001A38	LOCKWASHER 3/8, ZINC PLT .688 OD, .382 I	4.000 EA
10XN2520A32	1/4 X 2 HEX HEAD CAP SCR, GRADE 2	4.000 EA

<b>Parts List (continued)</b>		
<b>Part Number</b>	<b>Description</b>	<b>Quantity</b>
HW1001A25	LOCKWASHER 1/4, ZINC PLT .493 OD, .255 I	4.000 EA
HA2065A02	SLINGER, ALUM MODLE 36 & 37 DRILL RIG MT	1.000 EA
07FH1003A01	STANDARD 307 EXPLOSION PROOF FAN HOUSING	1.000 EA
10XN2520A12	O1/4-20X 3/4 HEX HEAD CAP	4.000 EA
07CB1502A01	CONDUIT BOX LID MACH (DUCTILE IRON)	1.000 EA
84XN2520J16	1/4-20 X 1 SOC HD CAP SCREW	4.000 EA
HW1001A25	LOCKWASHER 1/4, ZINC PLT .493 OD, .255 I	4.000 EA
80XN1032A07	SET SCREW, HEX XOCK, ZN	1.000 EA
HW2501F21	KEY, 5/16 SQ X 2.375	1.000 EA
HA7000A02	KEY RETAINER RING, 1 1/8 DIA, 1 3/8 DIA	1.000 EA
LB1081F	ALUM XP CAUTION LABEL (FS PLANT ONLY-	1.000 EA
LB1115N	LABEL,LIFTING DEVICE (ON ROLLS)	1.000 EA
85XU0407S04	4X1/4 U DRIVE PIN STAINLESS	6.000 EA
MJ1000A02	GREASE, POLYREX EM EXXON (USe 4824-15A)	0.050 LB
51XB1214A20	12-14X1.25 HXWSSLD SERTYB	1.000 EA
MG1025G29	WILKOFASST, 789.229, DARK CHARCOAL GRAY	0.036 GA
LB1119N	WARNING LABEL	1.000 EA
LC0145B01	CONNECTION LABEL	1.000 EA
NP0977XPSLEV	SS XP UL CSA-EEV CC CL-I GP-C&D	1.000 EA
07PA1011	PKG GRP, 07 CAST IRON PK1181	1.000 EA
MN416A01	TAG-INSTAL-MAINT no wire (1200/bx) 11/14	1.000 EA

**AC Induction Motor Performance Data**

Record # 33780 - Typical performance - not guaranteed values

<b>Winding:</b> 07WGX598-R007	<b>Type:</b> 0750M	<b>Enclosure:</b> XPFC
-------------------------------	--------------------	------------------------

Nameplate Data				380 V, 50 Hz: High Voltage Connection	
Rated Output (HP)	10//7.5			Full Load Torque	26.8 LB-FT
Volts	230/460//190/380			Start Configuration	direct on line
Full Load Amps	24.6/12.3//23.2/11.6			Breakdown Torque	90 LB-FT
R.P.M.	1765//1465			Pull-up Torque	58.1 LB-FT
Hz	60//50	Phase	3	Locked-rotor Torque	64.4 LB-FT
NEMA Design Code	A	KVA Code	J	Starting Current	92.9 A
Service Factor (S.F.)	1.15			No-load Current	5.49 A
NEMA Nom. Eff.	92.4	Power Factor	81	Line-line Res. @ 25°C	0.867 Ω
Rating - Duty	40C AMB-CONT			Temp. Rise @ Rated Load	48°C
S.F. Amps				Temp. Rise @ S.F. Load	58°C
				Locked-rotor Power Factor	39
				Rotor inertia	1.23 LB-FT <sup>2</sup>

Load Characteristics 380 V, 50 Hz, 7.5 HP

% of Rated Load	25	50	75	100	125	150	S.F.
Power Factor	39	61	74	80	83	85	82
Efficiency	89.3	93.4	92.3	91.9	90.9	89.7	91.3
Speed	1491	1484	1475	1468	1458	1449	1462
Line amperes	6.07	7.46	9.35	11.6	14.1	16.8	13.1

Performance Graph at 380V, 50Hz, 7.5HP Typical performance - Not guaranteed values

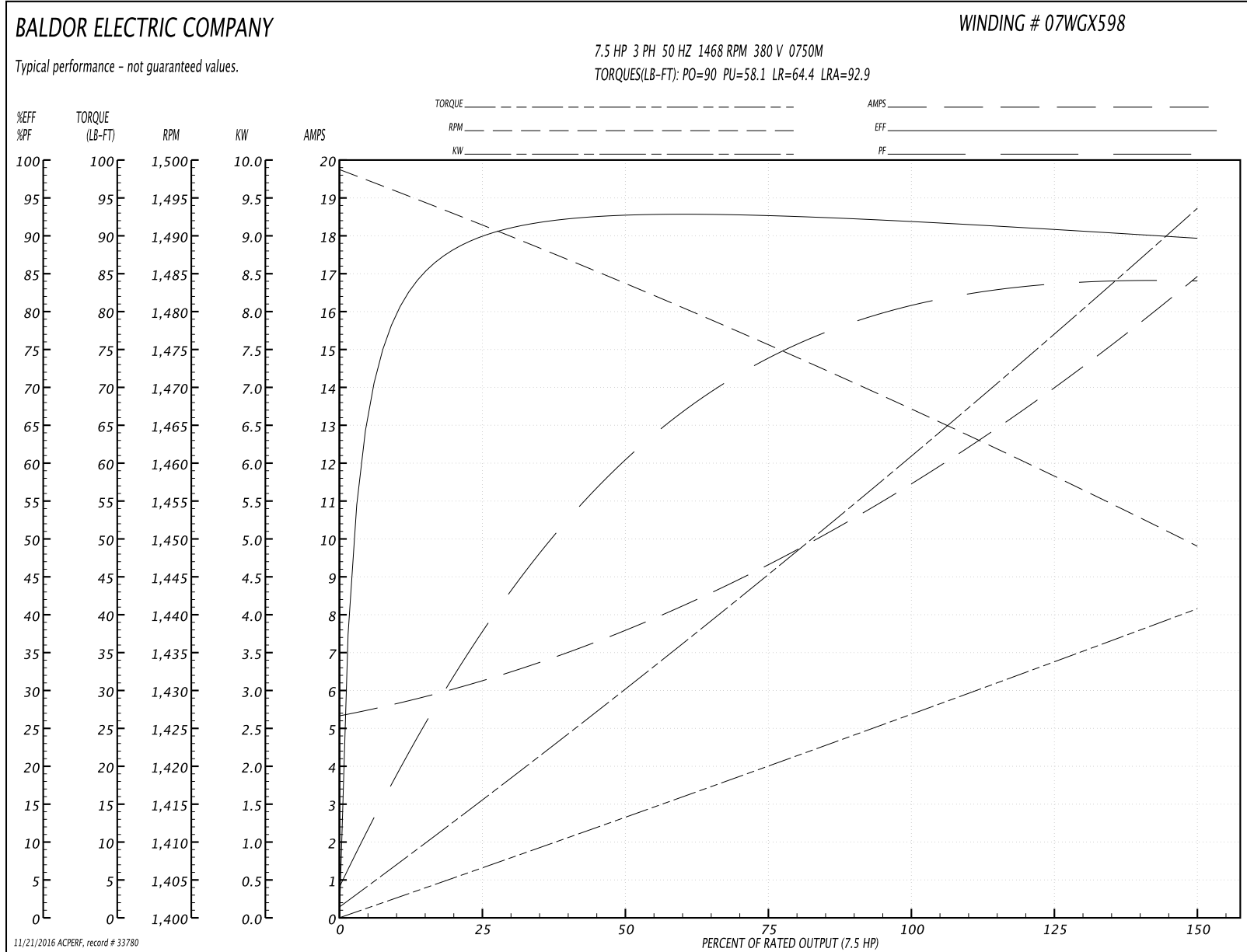

**AC Induction Motor Performance Data**

Record # 39054 - Typical performance - not guaranteed values

<b>Winding:</b> 07WGX598-R007	<b>Type:</b> 0750M	<b>Enclosure:</b> XPFC
-------------------------------	--------------------	------------------------

Nameplate Data				460 V, 60 Hz: High Voltage Connection	
Rated Output (HP)	10//7.5			Full Load Torque	29.7 LB-FT
Volts	230/460//190/380			Start Configuration	direct on line
Full Load Amps	24.6/12.3//23/11.5			Breakdown Torque	94.2 LB-FT
R.P.M.	1765//1465			Pull-up Torque	56.3 LB-FT
Hz	60//50	Phase	3	Locked-rotor Torque	62.4 LB-FT
NEMA Design Code	A	KVA Code	J	Starting Current	95.7 A
Service Factor (S.F.)	1.15			No-load Current	5.6 A
NEMA Nom. Eff.	92.4	Power Factor	81	Line-line Res. @ 25°C	0.867 Ω
Rating - Duty	40C AMB-CONT			Temp. Rise @ Rated Load	55°C
S.F. Amps				Temp. Rise @ S.F. Load	70°C
				Locked-rotor Power Factor	35
				Rotor inertia	1.23 LB-FT <sup>2</sup>

**Load Characteristics 460 V, 60 Hz, 10 HP**

% of Rated Load	25	50	75	100	125	150	S.F.
Power Factor	41	64	76	81	84	85	83
Efficiency	89.8	93.6	92.6	92.4	91.3	90.2	91.7
Speed	1790	1782	1772	1764	1753	1743	1757
Line amperes	6.28	7.9	10	12.5	15.3	18.3	14.2

Performance Graph at 460V, 60Hz, 10.0HP Typical performance - Not guaranteed values

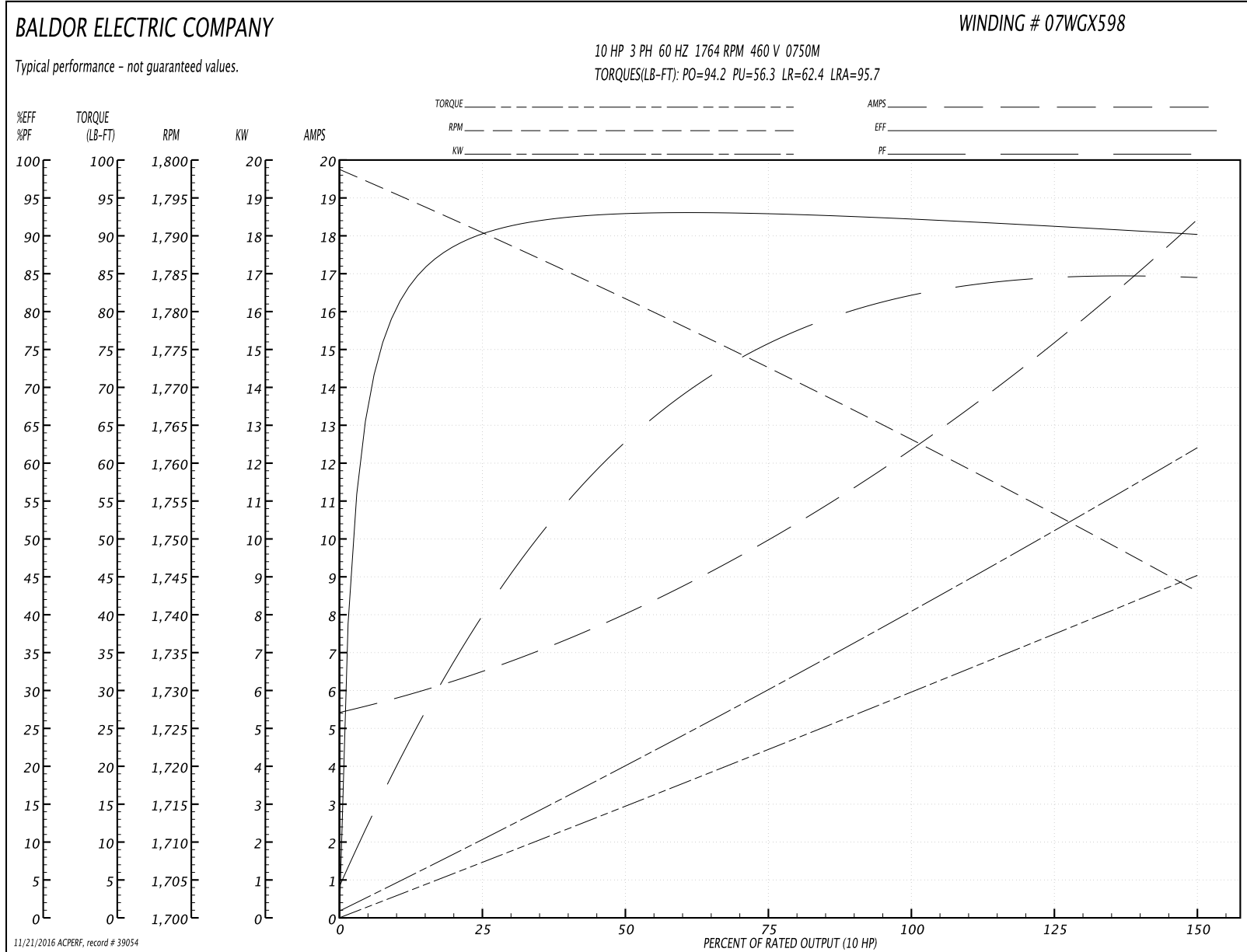

07LYJ232

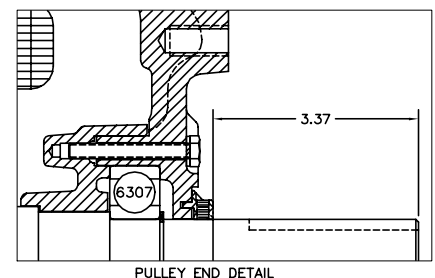
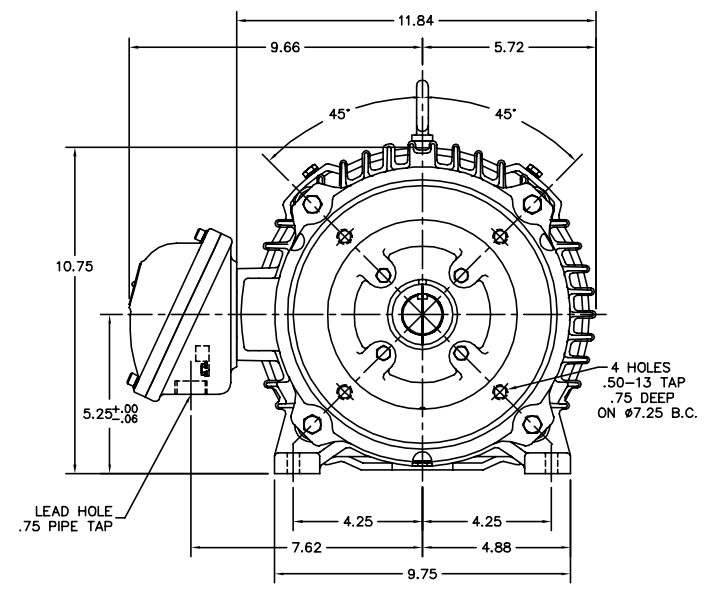
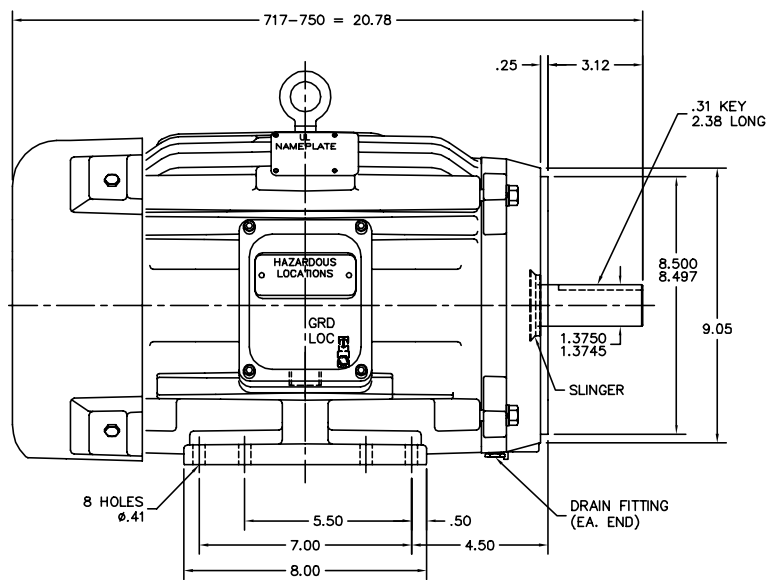

PULLEY END DETAIL

CUSTOMER IS RESPONSIBLE FOR DETERMINING THAT MOTOR PERFORMANCE IS SUITABLE IN THE APPLICATION.

REV. DESC: 07SH5145 WAS 07SH5088	
REV. LTR: B BY: OD REVISED: 11:58:36 05/22/2002 TDR: 271902	
FILE: AAA00076168	REF: 07LYJ232
MTL: -	

**BALDOR ELECTRIC Co.**

HORZ 213-5TC XPFC 307M CL-I GP-C&D (DRILL RIG MOTOR)

07LYJ232

CD0005



LOW VOLTAGE  
(2Y)



LINE

HIGH VOLTAGE  
(1Y)

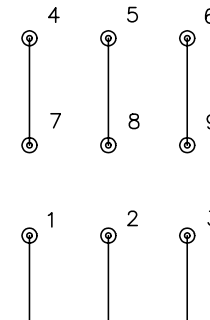

LINE

NOTES:

1. INTERCHANGE ANY TWO LINE LEADS TO REVERSE ROTATION.
2. OPTIONAL THERMOSTATS ARE PROVIDED WHEN SPECIFIED.
3. ACTUAL NUMBER OF INTERNAL PARALLEL CIRCUITS MAY BE A MULTIPLE OF THOSE SHOWN ABOVE.
4. LEAD COLORS ARE OPTIONAL. LEADS MUST ALWAYS BE NUMBERED AS SHOWN.

REV. DESC: REVISE TO SHOW OPTIONAL COLORS			
REV. LTR: E	BY: JLP	REVISED: 01/19/99 10:15	TDR: 0171435
90000		FILE: AAA00005140	MDL: -
		MTL: -	

**BALDOR ELECTRIC Co.**

3PH, DV, 9 LEADS

CD0005