

BALDOR® • ***RELIANCE***

Product Information Packet

ECP44352T-4

350HP,3565RPM,3PH,60HZ,449TS,A44144M,TEF

Part Detail							
Revision:	L	Status:	PRD/A	Change #:		Proprietary:	No
Type:	AC	Prod. Type:	A44144M	Elec. Spec:	A44WG1560	CD Diagram:	416820-036
Enclosure:	TEFC	Mfg Plant:		Mech. Spec:		Layout:	617427-006
Frame:	449TS	Mounting:	F1	Poles:	02	Created Date:	08-16-2012
Base:		Rotation:	R	Insulation:	F	Eff. Date:	01-26-2016
Leads:	3#2/0 (02 per group)					Replaced By:	
Literature:		Elec. Diagram:					

Nameplate NP3238									
CAT NO	ECP44352T-4	SPEC NO.	P44G3956						
HP	350	AMPS	370	VOLTS	460	DESIGN	B		
FRAME	449TS	RPM	3565	HZ	60	AMB	40	SF	1.15
D.E. BRG.DATA	6313	O.D.E. BRG.DATA	6313	PH	3	DUTY	CONT	INSUL.CLASS	F
D.E. BRG.	65BC03J30X	TYPE	P	ENCL	TEFC	CODE	F	NEMA NOM EFFICIENCY	95.8
O.D.E. BRG.	65BC03J30X	POWER FACTOR	91	MAX CORR KVAR	30.0	GUARANTEED EFFICIENCY	95.4		
3/4 LOAD EFF.	96.2	TEMP	= 230						
TEMP CODE	T2C	CT HZ	30-60	VT HZ	0-60				
CHP HZ	60-75								
INVERTER-TEMP-CODE	T2C								
SER.NO.		MOTOR WEIGHT	2965						

Parts List		
Part Number	Description	Quantity
SA249726	SA P44G3956	1.000 EA
RA236586	RA P44G3956	1.000 EA
NP3238	SS CP XEX SEVERE DUTY MAIN NP	1.000 EA
000692000FF	N/P	1.000 EA
000692000VD	LABEL WARNING	1.000 EA
004824015A	GREASE POLYREX EM	0.544 LB
032018008CK	HHCS 3/8-16X1L PLATED	4.000 EA
032018012BK	HHCS 5/16-16X1-1/2PLATED	4.000 EA
032018020FK	HHCS 3/4-10X2-1/2 PLTD.	4.000 EA
032018028CK	HHCS 3/8-16X3-1/2 PLTD.	3.000 EA
034180014DA	KEY 1/4X1/4X1-3/4 L	1.000 EA
034530072AB	P/NIP 1/8X9"L Threaded both ends	1.000 EA
034530072BB	PIPE NIPPLE,DE - 440-BS	1.000 EA
034631002AB	BUSH 1/4 TO 1/8 PLTD.	1.000 EA
035000001G	GREASE RELIEF FITTING, ALEMITE 317400	1.000 EA
034690005AB	PPLG 3/4 PLATED	1.000 EA
078548001R	FAN KB 234/150 (84) 400	1.000 EA
083199082RA	G28 SHORT FAN COVER W/BAFFLE ASSEMBLY	1.000 EA
089490097A	BRKT 089490102WCA	1.000 EA
410700004F	WSHR	1.000 EA
412118006A	DRAIN	1.000 EA
415072001B	CLAMP	1.000 EA
415096002A	CPLG 1/8 HEX TYPE	1.000 EA
032018004BK	HHCS 5/16-18X1/2 PLATED	3.000 EA

Parts List (continued)		
Part Number	Description	Quantity
032018006BK	HHCS 5/16-18X3/4 PLATED	3.000 EA
032018020FK	HHCS 3/4-10X2-1/2 PLTD.	4.000 EA
032018022CK	HHCS 3/8-16X2-3/4 PLTD	3.000 EA
034000013AB	WSHR 5/16" PLATED-440	3.000 EA
034017013AB	LCKW 5/16 STD. PLATED	3.000 EA
034530072AB	P/NIP 1/8X9"L Threaded both ends	1.000 EA
034530072BB	PIPE NIPPLE,DE - 440-BS	1.000 EA
034631002AB	BUSH 1/4 TO 1/8 PLTD.	1.000 EA
035000001G	GREASE RELIEF FITTING, ALEMITE 317400	1.000 EA
089490097A	BRKT 089490102WCA	1.000 EA
415915007K	GASK, 26" LAC	1.000 EA
412118006A	DRAIN	1.000 EA
415045002E	SLGR	1.000 EA
415096002A	CPLG 1/8 HEX TYPE	1.000 EA
702623022A	G28 AIR DEFLECTOR DRIVE END -- PLASTIC	1.000 EA
702623012A	THERMAL BARRIER, G28	1.000 EA
032018008BK	HHCS 5/16-18X1L PLATED	4.000 EA
032018008DK	HHCS 1/2-13X1 PLATED	4.000 EA
033512004LB	HHTTS 1/4-20X1/2 PLTD.	1.000 EA
035000001A	ALFTG 1/8" 1610-BL	1.000 EA
035000001A	ALFTG 1/8" 1610-BL	1.000 EA
067053014A	GASK 440	1.000 EA
076870000B	+CBCST BLKT - 440	1.000 EA
076871000A	+CBOX CVR BLKT - 449	1.000 EA

Product Information Packet: ECP44352T-4 - 350HP,3565RPM,3PH,60HZ,449TS,A44144M,TEF

406056007A	GASKET, 440	1.000 EA
406099000A	PLUG - FAN COVER 320-440	1.000 EA
415000103D	T/LUG #4AWG-1/0AWG W/HOLE FOR .250 BOLT	1.000 EA
418150003A	GREASE FITTING CAP	1.000 EA
418150003A	GREASE FITTING CAP	1.000 EA
033775004EA	DRSCR #6-1/4 304 S.S.	2.000 EA
034180024HA	KEY 5/8X5/8X3 L	1.000 EA
MG1025N19	WILKO 778.50 BLUE GREEN - 55 GAL DRUMS	0.375 GA
004824003CBY	WILKO PAINT 060.02 - ACTIVATOR	0.094 GA
L482401016	SPRAY AC-29-7S	0.019 GA
421948051	LABEL, MYLAR	1.000 EA
PK5005A01	WOOD BASE 449 60 X 41-1/2 BLT 25 X 18	1.000 EA
LB1449	DIV-2/NEC WARNING LABEL	1.000 EA
000613006PU	N/P (RELEASE QTY 10,000) UL CSA LABLE	1.000 EA

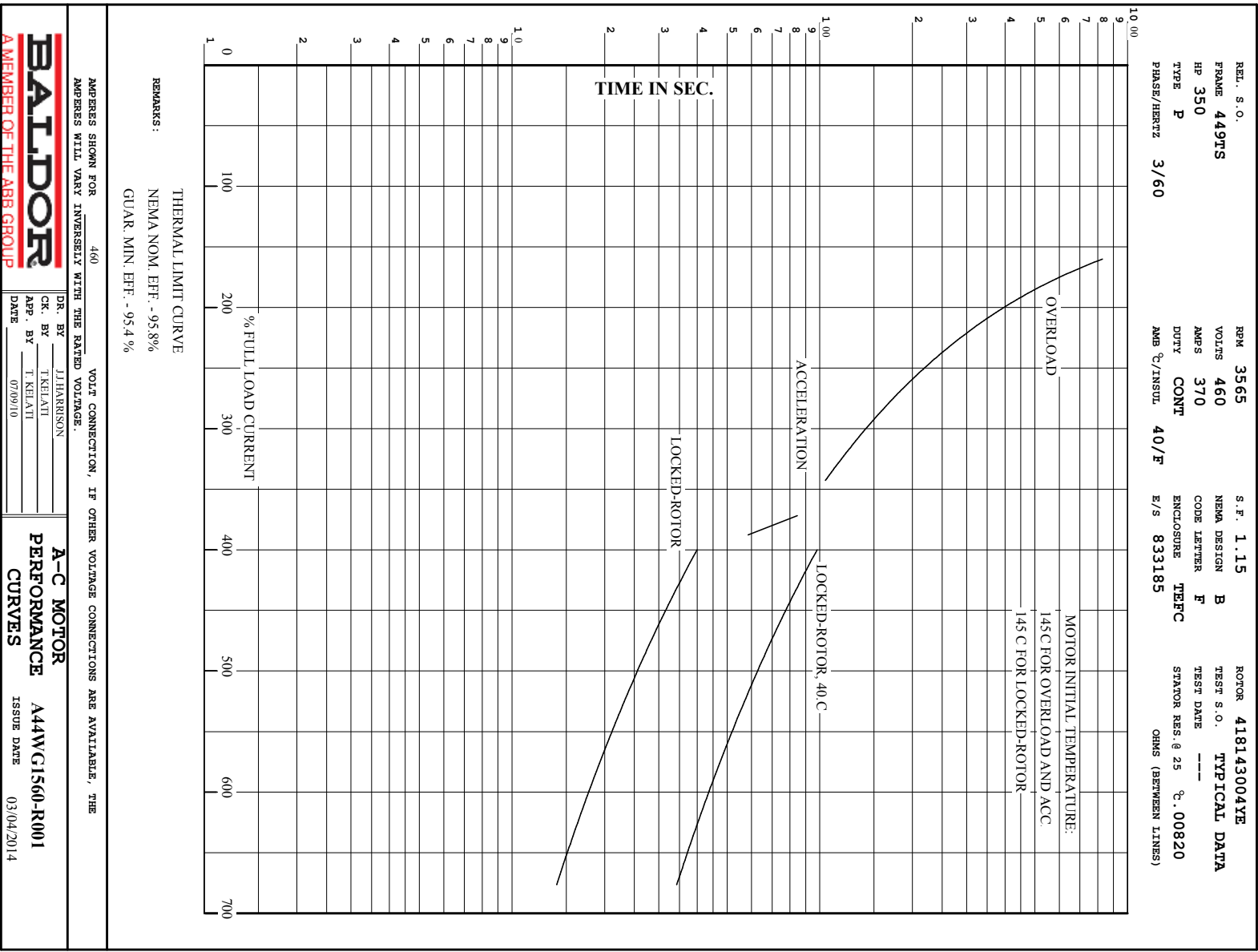

BALDOR
A MEMBER OF THE ABB GROUP

DR. BY J. HARRISON
CK. BY T. KELATI
APP. BY T. KELATI
DATE 07/09/10

A-C MOTOR
PERFORMANCE
CURVES

A44W/G1560-R001
ISSUE DATE 03/04/2014

REL. S.O.	FRAME	HP	TYPE	PHASE/HERTZ	RPM	VOLTS
	449TS	350	P	3/60	3565	460
AMPS	DUTY	AMB °C/INSUL.	S.F.	NEMA DESIGN	CODE LETTER	ENCL.
370	CONT	40/F	1.15	B	F	TEFC
E/S	ROTOR	TEST S.O.	TEST DATE	STATOR RES. @25 °C (OHMS BETWEEN LINES)		
833185	418143004YE	---	---	.00820		

PERFORMANCE

LOAD	HP	AMPERES	RPM	POWER FACTOR %	EFFICIENCY %
NO LOAD	0	53.1	3600	9.73	0
1/4	87.6	112	3592	78.4	93.5
2/4	175	191	3584	89.5	95.8
3/4	263	279	3576	91.8	96.2
4/4	350	373	3567	91.4	96.0
5/4	437	471	3557	90.8	95.7

SPEED TORQUE

	RPM	TORQUE % FULL LOAD	TORQUE LB.-FT.	AMPERES
LOCKED ROTOR	0	151	778	2293
PULL UP	1620	128	657	2109
BREAKDOWN	3465	249	1280	1119
FULL LOAD	3567	100	515	373

AMPERES SHOWN FOR 460. VOLT CONNECTION. IF OTHER VOLTAGE CONNECTIONS ARE AVAILABLE, THE AMPERES WILL VARY INVERSELY WITH THE RATED VOLTAGE

REMARKS: TYPICAL DATA
NEMA NOM. EFF. - 95.8%
GUAR. MIN. EFF. - 95.4 %



DR. BY J. J. HARRISON
CK. BY T. KEIARTI
APP. BY T. KEIARTI
DATE 07/09/10

A-C MOTOR PERFORMANCE DATA
A44WG1560-R001
ISSUE DATE 03/04/20

A MEMBER OF THE ABB GROUP

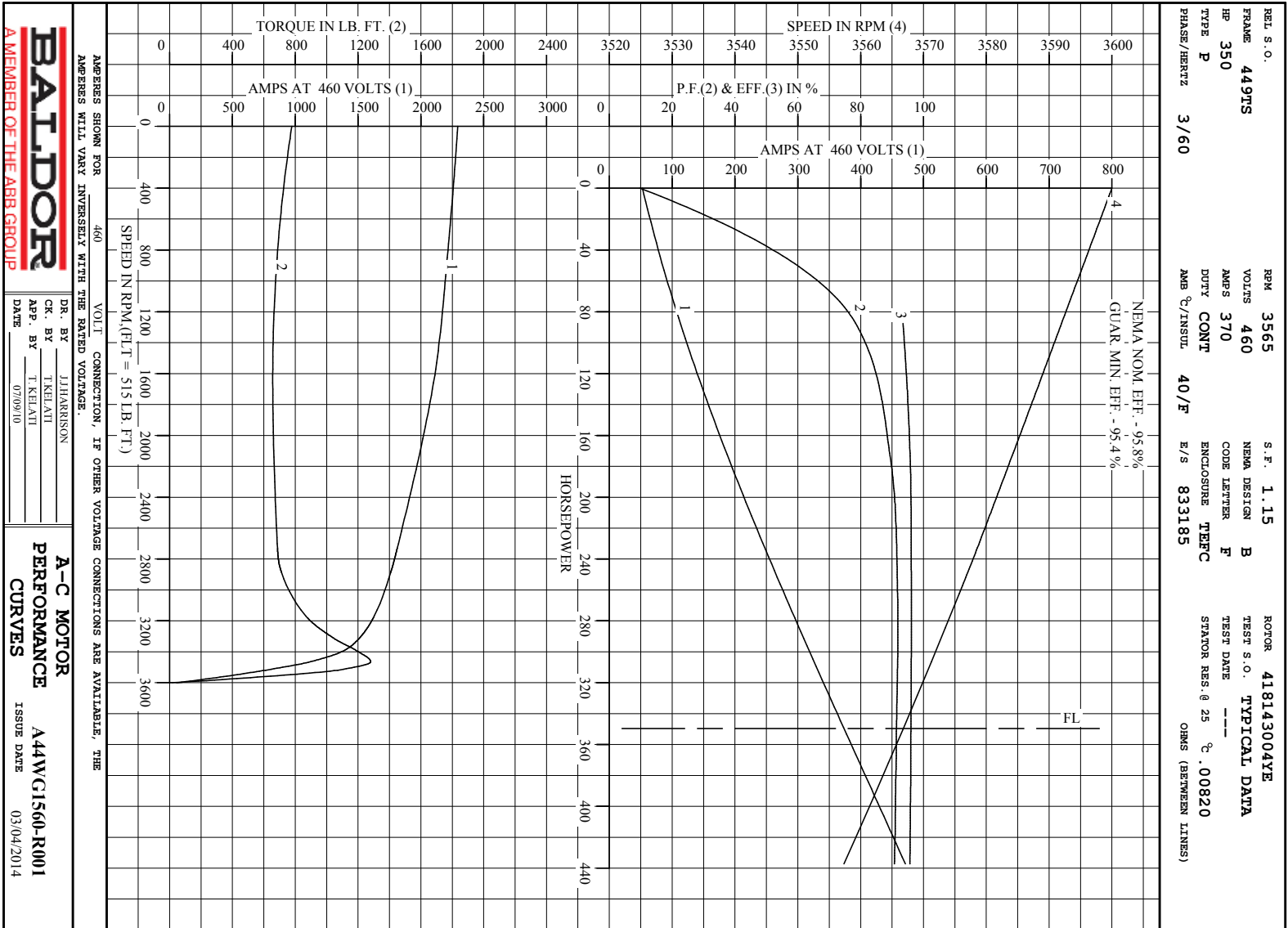

BALDOR
A MEMBER OF THE ABB GROUP

DR. BY: JHARRISON
 CK. BY: TKEHATI
 App. BY: TKEHATI
 DATE: 07/09/10

A-C MOTOR
PERFORMANCE
CURVES
 A44WC1560-R001
 ISSUE DATE: 03/04/2014

Printed on 3/4/14 7:53 @ fagsun

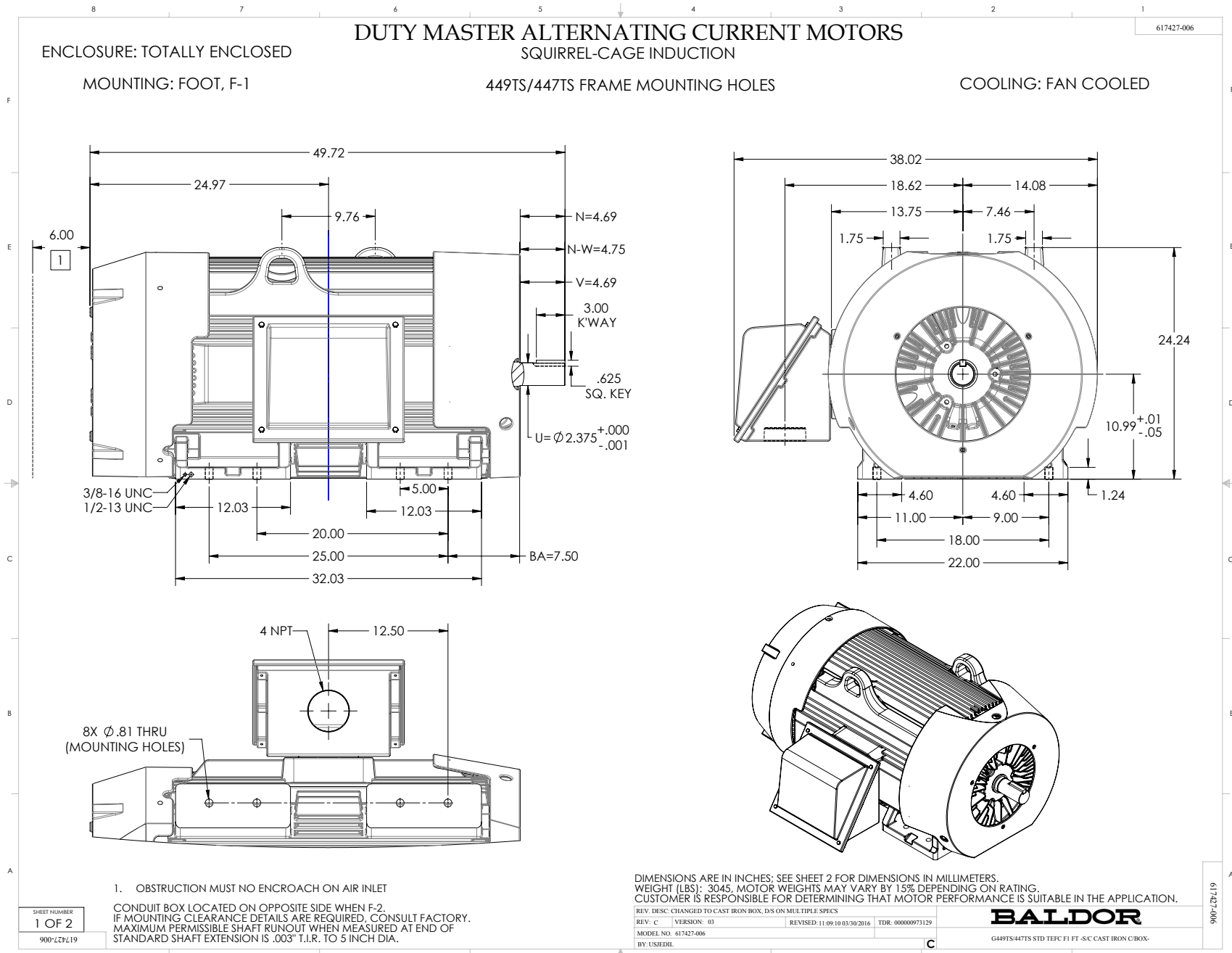

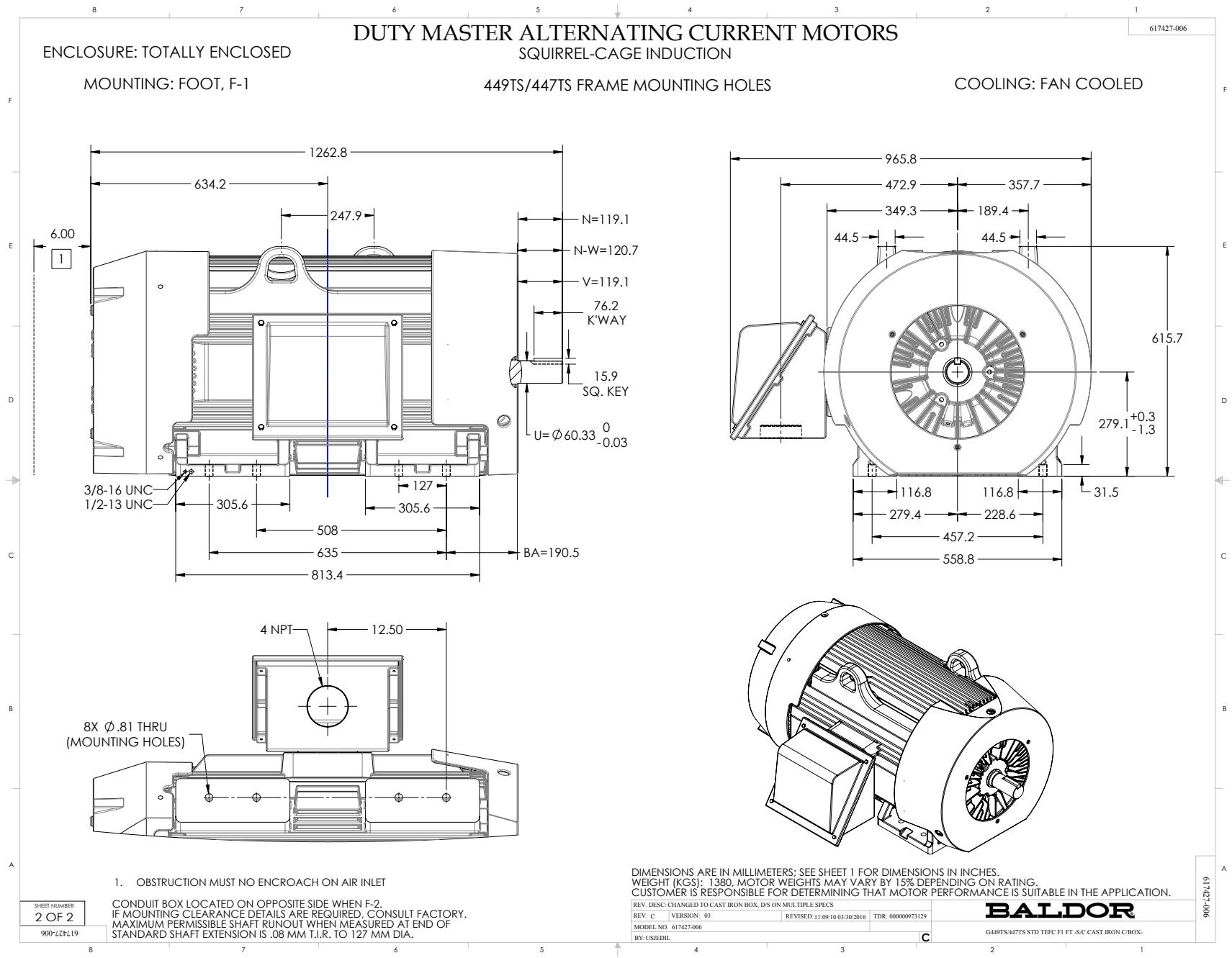

SHEET NUMBER
2 OF 2
9007-27119

416820-036

A-C MOTOR
 CONNECTION DIAGRAM
 STANDARD 3 LEAD CONNECTED



(N.P. 1575-BA)

416820-036

REV. DESC: LOADED TO BUS, C/R 335225		
REV. LTR: -	VERSION: 00	TDR: 000000538207
FILE: \MGA\00000\682	REVISED: 11:54:06 04/30/2010	
MTL: -	BY: RAGRA	

BALDOR

CONN DIAG - STANDARD 3 LEAD

SH 1 of 1

Marketing maintained PDF of MN408:

<http://www.baldor.com/support/Literature/Load.ashx/MN408?ManNumber=MN408>

Marketing maintained PDF of MN416:

<http://www.baldor.com/support/Literature/Load.ashx/MN416?ManNumber=MN416>