

BALDOR® • **RELIANCE**

Product Information Packet

EM7670T-I

10HP,1760RPM,3PH,60HZ,215T,0748M,XPFC,F1

Part Detail							
Revision:	B	Status:	PRD/A	Change #:		Proprietary:	No
Type:	AC	Prod. Type:	0748M	Elec. Spec:	07WGX776	CD Diagram:	CD0005
Enclosure:	XPFC	Mfg Plant:		Mech. Spec:	07N420	Layout:	07LYN420
Frame:	215T	Mounting:	F1	Poles:	04	Created Date:	08-27-2015
Base:	RG	Rotation:	R	Insulation:	F	Eff. Date:	05-12-2016
Leads:	9#14					Replaced By:	
Literature:		Elec. Diagram:					

Nameplate NP1044XPSLEV										
NO.							CC	010A		
SER.							TEMP CODE	T3C		
SPEC.	07N420X776G1									
CAT.NO.	EM7670T-I									
HP	10									
VOLTS	230/460									
AMPS	25/12.5									
RPM	1760						MOTOR WEIGHT	249		
HERTZ	60	PH	3	CL	F	DE BRG	6307			
SER.F.	1.15	DES	A	CODE	H	ODE BRG	6206			
FRAME	215T		GREASE		POLYREX EM					
RATING	40C AMB-CONT									
USABLE AT 208V					NEMA-NOM-EFF	92.4		PF	82	
	55C @ 1.00SF									

Parts List		
Part Number	Description	Quantity
SA306930	SA 07N420X776G1	1.000 EA
RA294205	RA 07N420X776G1	1.000 EA
37FN3002C01	EXFN, PLASTIC, 6.00 OD, 1.155 ID	1.000 EA
HA3210E08	.250X 7/8 PIN 312-57	1.000 EA
10XN2520S06	1/4 20X3/8 HX HD CAP S.S.	1.000 EA
WD1000B16	T&B CX70TN TERMINAL	1.000 EA
HW3201A05	3/8-16 EYEBOLT	1.000 EA
07CB1000A12	CONDUIT BOX, 1.88 SQ MTG PATTERN & 1.00	1.000 EA
10XN3118A16	5/16-18X1 HEX HD CAP	4.000 EA
HW1001A31	LOCKWASHER 5/16, ZINC PLT.591 OD, .319 I	4.000 EA
11XW1032G06	10-32 X .38, TAPTITE II, HEX WSHR SLTD U	1.000 EA
WD1000B17	T&B CX35TN TERMINAL	1.000 EA
07EP1707A08	FRONT ENDPLATE EXPLOSION PROOF(GROUP E M	1.000 EA
HA2009A25	SLINGER, FOR GROUP E MOTORS - 206 BRG.	1.000 EA
80XN0632A10	SET SCREW,#6-32 X .62 LG.HEX SOC. HD.	2.000 EA
HW4500A01	1641B(ALEMITE)400 UNIV, GREASE FITT	1.000 EA
HW4500A19	1/4-28X1/4 SLOTTED PLUG F/S	1.000 EA
HW4506A02	BREATHER/DRAIN-EXP PROOF-.125-27 NPTF AI	1.000 EA
HW3022E05	.125 DIA X .500 ROLLED SPRING PIN	1.000 EA
10XN3816K28	3/8-16 X 1.75 HEX HD CAP SCREW, GRADE 5	4.000 EA
HW1001A38	LOCKWASHER 3/8, ZINC PLT .688 OD, .382 I	4.000 EA
HW5100A06	W2420-025 WVY WSHR (WB)	1.000 EA
10XN2520A36	1/4-20X 2 1/4 HEX HD X	4.000 EA
HW1001A25	LOCKWASHER 1/4, ZINC PLT .493 OD, .255 I	4.000 EA

Parts List (continued)		
Part Number	Description	Quantity
07EP1709A09	PU ENDPLATE EXP PROOF W/LOK'D BRG. GROUP	1.000 EA
HA2009A56	SLINGER, FOR GROUP E MOTORS - 307 BRG.	1.000 EA
80XN0632A10	SET SCREW,#6-32 X .62 LG.HEX SOC. HD.	2.000 EA
HW4500A01	1641B(ALEMITE)400 UNIV, GREASE FITT	1.000 EA
HW4500A19	1/4-28X1/4 SLOTTED PLUG F/S	1.000 EA
HW4506A02	BREATHER/DRAIN-EXP PROOF-.125-27 NPTF AI	1.000 EA
HW3022E05	.125 DIA X .500 ROLLED SPRING PIN	1.000 EA
10XN3816K28	3/8-16 X 1.75 HEX HD CAP SCREW, GRADE 5	4.000 EA
HW1001A38	LOCKWASHER 3/8, ZINC PLT .688 OD, .382 I	4.000 EA
51XB1214A20	12-14X1.25 HXWSSLD SERTYB	1.000 EA
07FH1003A05	FAN HOUSING 307 EXPLOSION PROOF W/ GREAS	1.000 EA
10XN2520A12	O1/4-20X 3/4 HEX HEAD CAP	4.000 EA
07CB1502A01	CONDUIT BOX LID MACH (DUCTILE IRON)	1.000 EA
10XN2520K16	1/4-20 X 1" HX HD SCRW GRADE 5, ZINC P	4.000 EA
HW1001A25	LOCKWASHER 1/4, ZINC PLT .493 OD, .255 I	4.000 EA
HW2501F21	KEY, 5/16 SQ X 2.375	1.000 EA
HA7000A02	KEY RETAINER RING, 1 1/8 DIA, 1 3/8 DIA	1.000 EA
85XU0407S04	4X1/4 U DRIVE PIN STAINLESS	6.000 EA
LB1081F	ALUM XP CAUTION LABEL (FS PLANT ONLY-	1.000 EA
LB1115N	LABEL,LIFTING DEVICE (ON ROLLS)	1.000 EA
MJ1000A02	GREASE, POLYREX EM EXXON (USe 4824-15A)	0.050 LB
MG1025G29	WILKOFASST, 789.229, DARK CHARCOAL GRAY	0.036 GA
MN416A01	TAG-INSTAL-MAINT no wire (1000/bx) 11/14	1.000 EA
LB1119N	WARNING LABEL	1.000 EA

LC0145B01	CONNECTION LABEL	1.000 EA
NP1044XPSLEV	SS XP UL CSA-EEV CC CL-I GP-D	1.000 EA
07PA1011	PKG GRP, 07 CAST IRON PK1181	1.000 EA
10XL3808A28	3/8 X 1 3/4" LAG SCREW	2.000 EA

AC Induction Motor Performance Data

Record # 53852 - Typical performance - not guaranteed values

Winding: 07WGX776-R052	Type: 0748M	Enclosure: XPFC
-------------------------------	--------------------	------------------------

Nameplate Data				460 V, 60 Hz: High Voltage Connection	
Rated Output (HP)	10			Full Load Torque	29.8 LB-FT
Volts	230/460			Start Configuration	direct on line
Full Load Amps	25/12.5			Breakdown Torque	87 LB-FT
R.P.M.	1760			Pull-up Torque	51.9 LB-FT
Hz	60	Phase	3	Locked-rotor Torque	57.5 LB-FT
NEMA Design Code	A	KVA Code	H	Starting Current	96.2 A
Service Factor (S.F.)	1.15			No-load Current	5.12 A
NEMA Nom. Eff.	92.4	Power Factor	82	Line-line Res. @ 25°C	0.958 Ω
Rating - Duty	40C AMB-CONT			Temp. Rise @ Rated Load	60°C
S.F. Amps				Temp. Rise @ S.F. Load	74°C
				Locked-rotor Power Factor	35.2
				Rotor inertia	1.18 LB-FT ²

Load Characteristics 460 V, 60 Hz, 10 HP

% of Rated Load	25	50	75	100	125	150	S.F.
Power Factor	44	67	78	82	84	85	83
Efficiency	89.7	92.9	93	92.4	91.2	90.2	91.7
Speed	1790	1781	1771	1762	1750	1739	1755
Line amperes	5.84	7.52	9.75	12.3	15.2	18.3	14

Performance Graph at 460V, 60Hz, 10.0HP Typical performance - Not guaranteed values

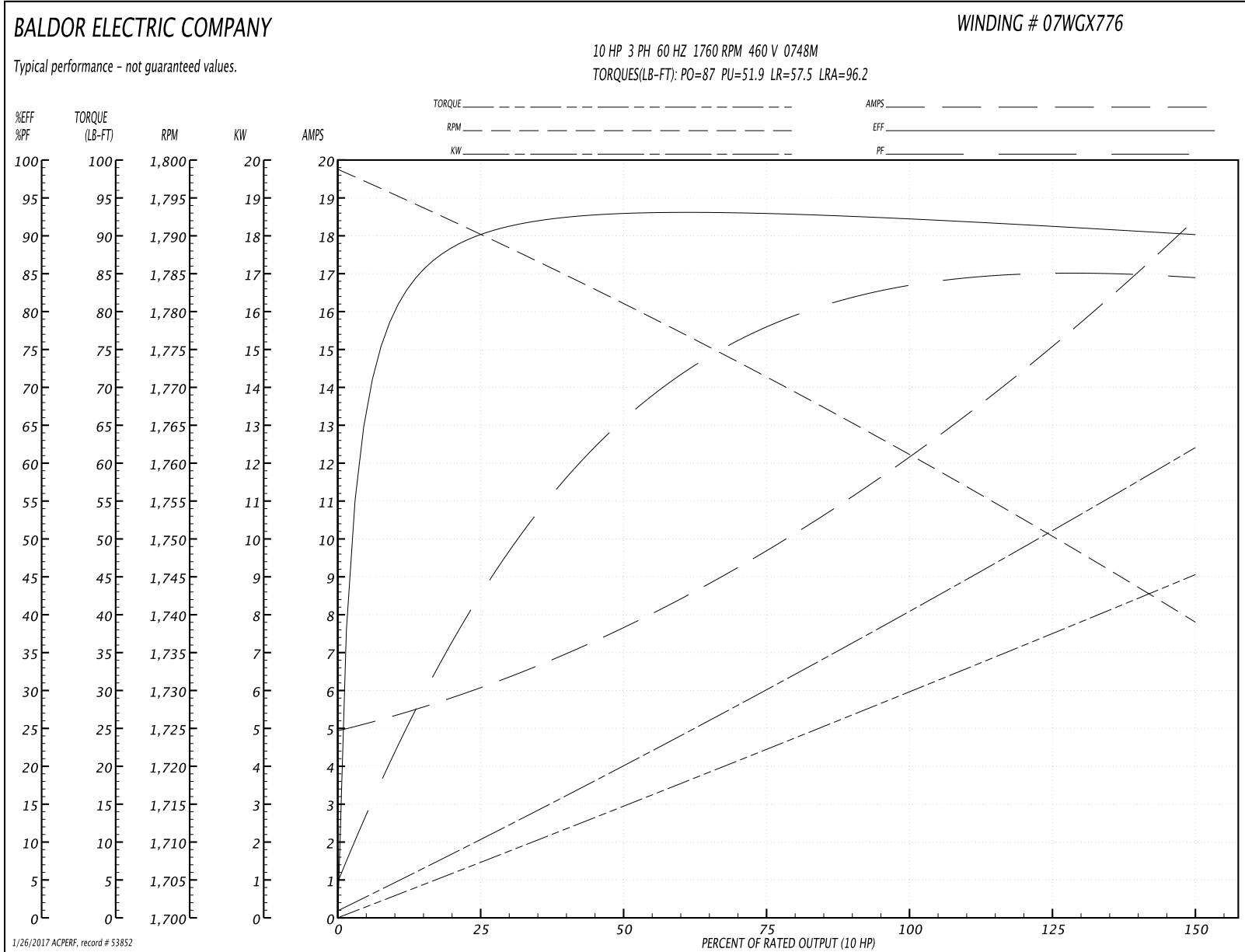

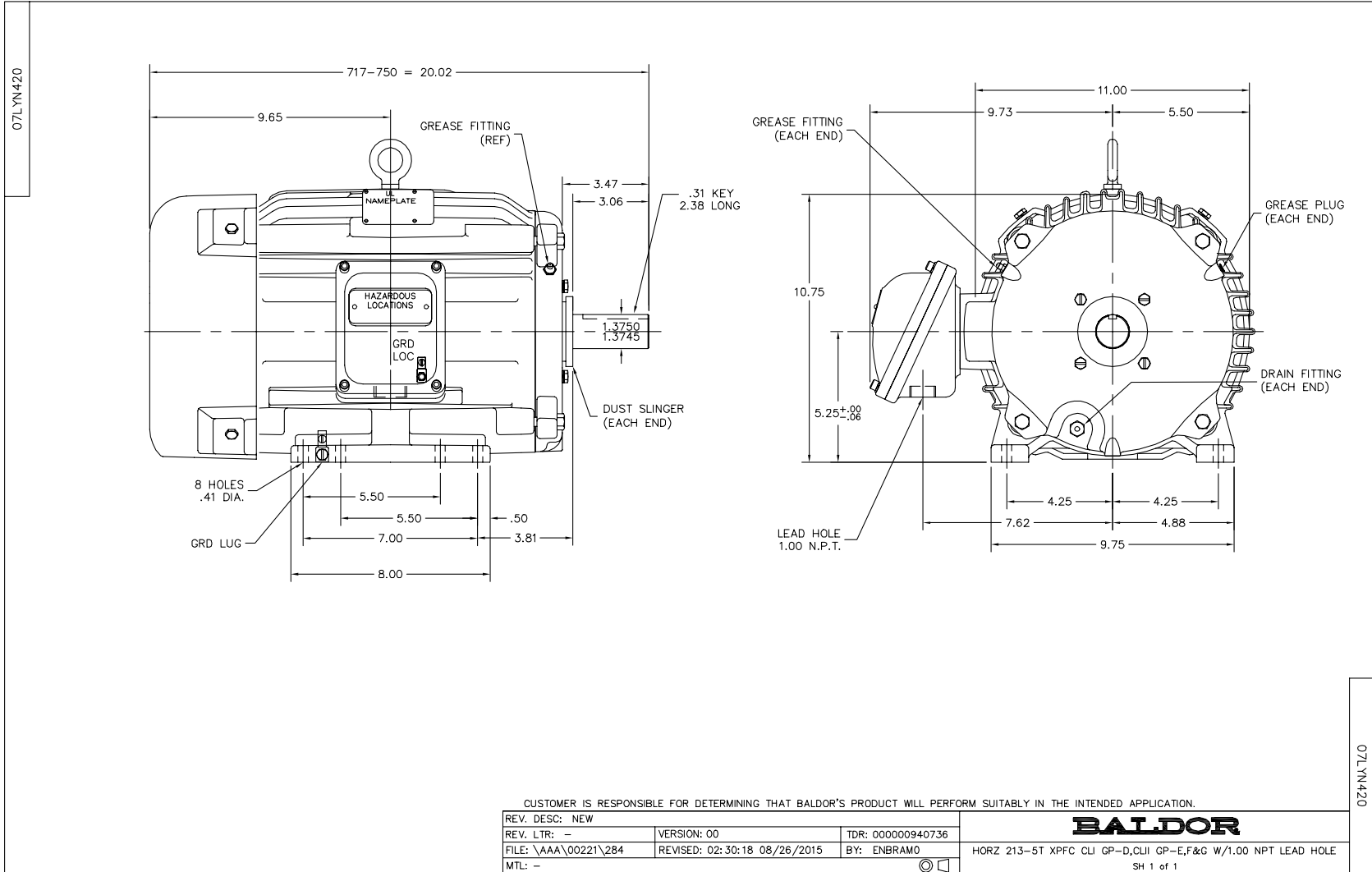

CD0005



LOW VOLTAGE
(2Y)



LINE

HIGH VOLTAGE
(1Y)



LINE

NOTES:

1. INTERCHANGE ANY TWO LINE LEADS TO REVERSE ROTATION.
2. OPTIONAL THERMOSTATS ARE PROVIDED WHEN SPECIFIED.
3. ACTUAL NUMBER OF INTERNAL PARALLEL CIRCUITS MAY BE A MULTIPLE OF THOSE SHOWN ABOVE.
4. LEAD COLORS ARE OPTIONAL. LEADS MUST ALWAYS BE NUMBERED AS SHOWN.

REV. DESC: REVISE TO SHOW OPTIONAL COLORS			
REV. LTR: E	BY: JLP	REVISED: 01/19/99 10:15	TDR: 0171435
90000		FILE: AAA00005140	MDL: -
		MTL: -	

BALDOR ELECTRIC Co.

3PH, DV, 9 LEADS

CD0005