

BERKELEY® SSHM Series Self-Priming Multi-Stage Centrifugal Pumps



The SSHM multi-stage series of sprinkler pumps delivers high-performance without priming problems and delays. The SSHM multi-stage series is designed for minimal electrical consumption and quiet operation from the professional grade motor. The new SSHM multi-stage series offers first-in-class priming capabilities of up to 20 foot lifts!

APPLICATIONS

- Residential and commercial turf irrigation
- Residential water systems
- Shower and washing systems
- Water transfer
- Heating and air conditioning systems
- Water features and fountains

ORDERING INFORMATION

Catalog Number	HP	Pipe Tapping Sizes		Motor Voltage	Approx. Wt. Lbs.
		Suction	Discharge		
B82456	2	1-1/2" NPT	1-1/4" NPT	230	95
B82639	2	1-1/2" NPT	1-1/4" NPT	230/460	95

SPECIFICATIONS

Motor Bracket and Integral Pump Base – Close-grained cast iron, 1-1/2" NPT inlet connection, stable heavy-duty design for rigid pipe and solid base mountings

Discharge – Close-grained cast iron, 1-1/4" NPT discharge connection, with easy-access drain-port for end of season draining and winterization

Impellers and Diffusers – Noryl® precision molded extra-smooth ports to maximize efficiency and performance

Outer Shell – Polished 304 stainless steel

Shaft – 303 stainless steel

Priming Valve – Special brass priming valve, patented for trouble-free operation during the initial pump priming

Mechanical Seal – High-pressure seal, carbon-ceramic seal faces, Buna-N elastomers

Heavy Duty Motor – 2 HP, single-phase, 3450RPM, 230 Volt, high-service factor, capacitor-start/capacitor-run, open-drip proof motor, rated for continuous-duty operation. 230/460 TEFC available

Maximum Inlet Pressure – 20 PSI

Maximum Discharge Pressure – 130 PSI

Maximum Operating Temperature – 120°F (49°C)

Maximum Suction Lift – 20 feet

Number of Stages – 4

Noryl® is a registered trademark of General Electric Co.
All other brand or product names are trademarks or registered marks of Pentair Ltd.

BERKELEY® SSHM Series Self-Priming Multi-Stage Centrifugal Pumps

PUMP PERFORMANCE

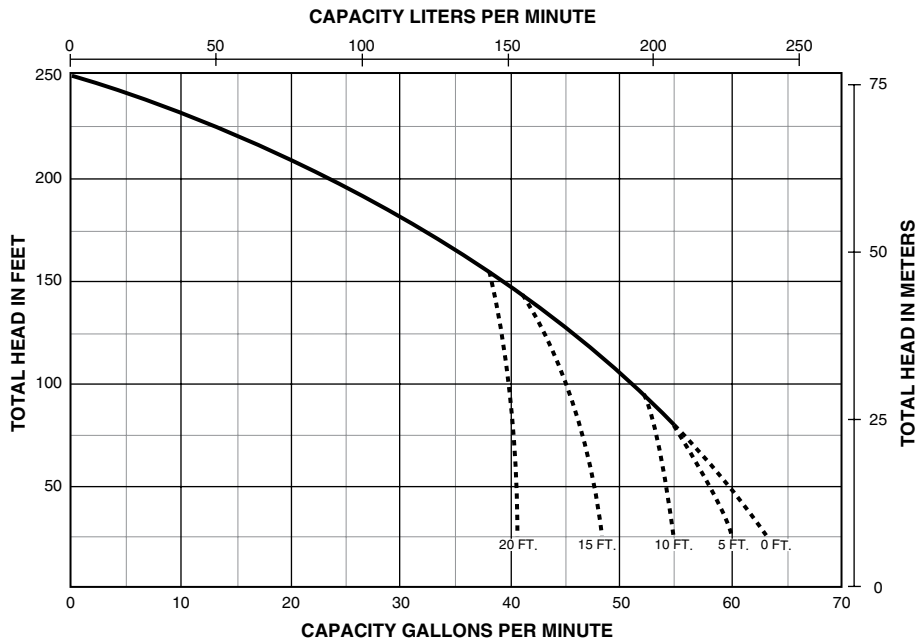

NOTE: Dotted lines indicate performance reduction at high suction lift.

PUMP PERFORMANCE (Capacity in Gallons Per Minute)

Catalog Number	HP	Discharge Pressure		Suction Lift in Feet			
		PSI	Feet Head	5'	10'	15'	20'
B82456 B82639	2	20	46	57	54	47	40
		30	69	56	53	46	39
		40	92	52	50	44	39
		50	115	47	46	43	38
		60	138	43	42	41	37

OUTLINE DIMENSIONS

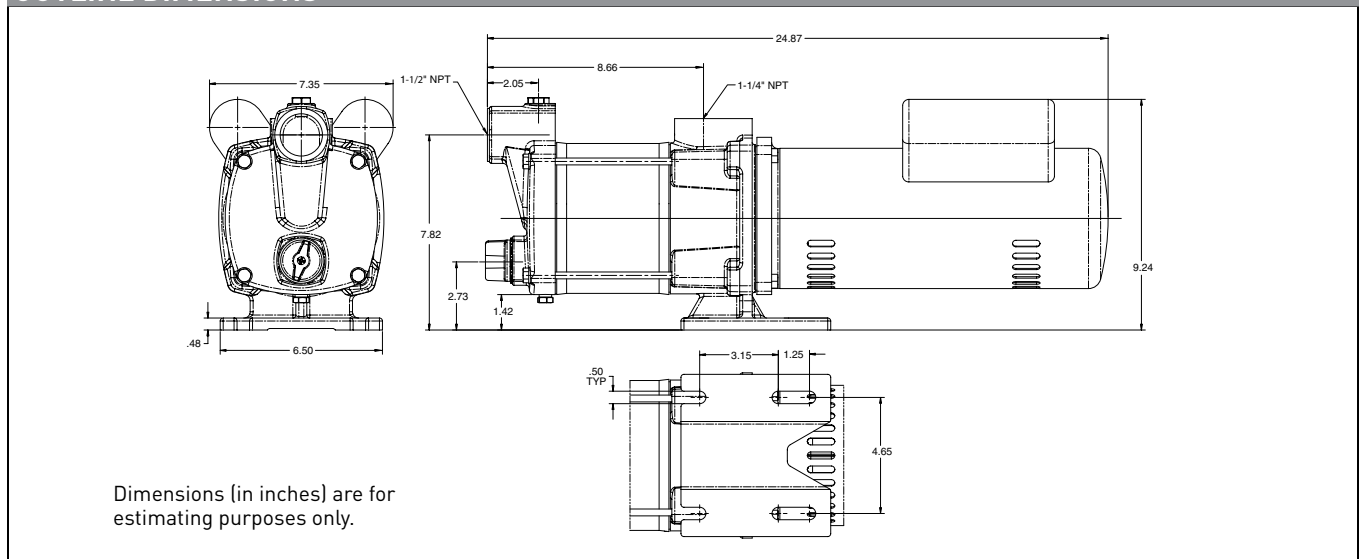

Dimensions (in inches) are for estimating purposes only.



293 WRIGHT STREET, DELAVAN, WI 53115 WWW.BERKELEYPUMPS.COM PH: 888-782-7483 ORDERS FAX: 800-426-9446
Because we are continuously improving our products and services, Pentair reserves the right to change specifications without prior notice.