

# burks®

## INSTALLATION AND OPERATION MANUAL

### Self-Priming Centrifugal Pumps

**Series WT**  
For Water and  
Other 1.00 S.G. Fluids

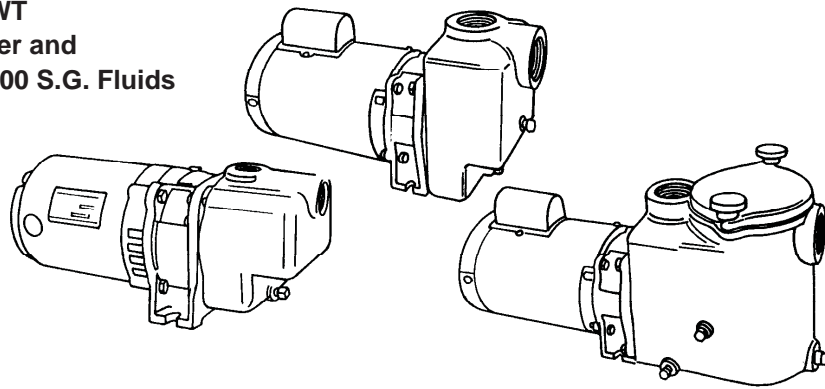

**Series WPT**  
For Perchloroethylene and  
Other 1.62 S.G. Fluids

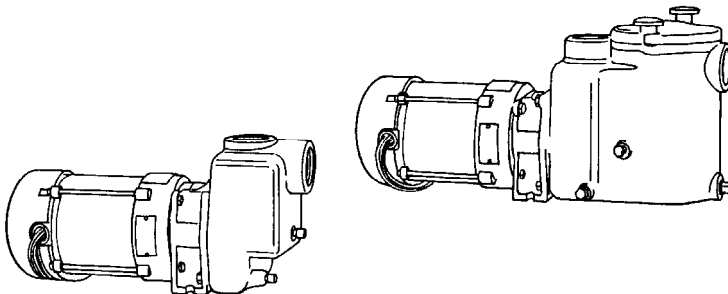

#### IMPORTANT!

*Read all instructions in this manual before operating pump.*

*DO NOT work on pump until you are sure pump and associated piping are totally depressurized, pump and motor have cooled down, and electricity to the motor has been shut off and locked out. As a result of Crane Pumps & Systems, Inc., constant product improvement program, product changes may occur. As such Crane Pumps & Systems reserves the right to change product without prior written notification.*

**CRANE**  
®

A Crane Co. Company

#### PUMPS & SYSTEMS

420 Third Street  
Piqua, Ohio 45356  
Phone: (937) 778-8947  
Fax: (937) 773-7157  
www.cranepumps.com

83 West Drive, Bramton  
Ontario, Canada L6T 2J6  
Phone: (905) 457-6223  
Fax: (905) 457-2650

Form No. F0741D-Rev. F

# SAFETY FIRST!

Please Read This Before Installing Or Operating Pump. This information is provided for **SAFETY** and to **PREVENT EQUIPMENT PROBLEMS**. To help recognize this information, observe the following symbols:



**IMPORTANT!** Warns about hazards that can result in personal injury or indicates factors concerned with assembly, installation, operation, or maintenance which could result in damage to the machine or equipment if ignored.

**CAUTION!** Warns about hazards that **can or will cause minor** personal injury or property damage if ignored. Used with symbols below.

**WARNING!** Warns about hazards that can or will cause serious personal injury, death, or major property damage if ignored. Used with symbols below.



Hazardous fluids can cause fire or explosions, burns or death could result.



Extremely hot - Severe burns can occur on contact.



Biohazard can cause serious personal injury.



Hazardous fluids can Hazardous pressure, eruptions or explosions could cause personal injury or property damage.



Rotating machinery Amputation or severe laceration can result.



Hazardous voltage can shock, burn or cause death.

Only qualified personnel should install, operate and repair pump. Any wiring of pumps should be performed by a qualified electrician.

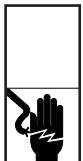

**WARNING!** To reduce risk of electrical shock, pumps and control panels must be properly grounded in accordance with the National Electric Code (NEC) or the Canadian Electrical Code (CEC) and all applicable state, province, local codes and ordinances. Improper grounding voids warranty.



**WARNING!** To reduce risk of electrical shock, always disconnect the pump from the power source before handling or servicing. Lock out power and tag.



**WARNING!** Operation against a closed discharge valve will cause premature bearing and seal failure on any pump, and on end suction and self priming pump the heat build may cause the generation of steam with resulting dangerous pressures. It is recommended that a high case temperature switch or pressure relief valve be installed on the pump body.



**CAUTION!** Pumps build up heat and pressure during operation-allow time for pumps to cool before handling or servicing.



**WARNING!** This pump is designed to handle materials which could cause illness or disease through direct exposure. Wear adequate protective clothing when working on the pump or piping.



**WARNING!** Do not pump hazardous materials (flammable, caustic, etc.) unless the pump is specifically designed and designated to handle them.



**WARNING!** Do not wear loose clothing that may become entangled in moving parts.



**WARNING!** Keep clear of suction and discharge openings. **DO NOT** insert fingers in pump with power connected.



Make sure lifting handles are securely fastened each time before lifting. **DO NOT** operate pump without safety devices in place. Always replace safety devices that have been removed during service or repair. Secure the pump in its operating position so it can not tip over, fall or slide.



**WARNING!** To reduce risk of electrical shock, all wiring and junction connections should be made per the NEC or CEC and applicable state or province and local codes. Requirements may vary depending on usage and location.



**WARNING!** Products returned must be cleaned, sanitized, or decontaminated as necessary prior to shipment, to insure that employees will not be exposed to health hazards in handling said material. All Applicable Laws And Regulations Shall Apply.



Crane Pumps & Systems, Inc. is not responsible for losses, injury, or death resulting from a failure to observe these safety precautions, misuse or abuse of pumps or equipment.

## GENERAL INFORMATION

### To the Purchaser:

Congratulations! You are the owner of one of the finest pumps on the market today. Burks® Pumps are products engineered and manufactured of high quality components. Over eighty years of pump building experience along with a continuing quality assurance program combine to produce a pump which will stand up to the toughest pumping projects. This manual will provide helpful information concerning installation, maintenance, and proper service guidelines.

### Receiving:

Upon receiving the pump, it should be inspected for damage or shortages. If damage has occurred, file a claim immediately with the company that delivered the pump. If the manual is removed from the crating, do not lose or misplace.

### Storage:

**Short Term** - Burks Pumps are manufactured for efficient performance following long inoperative periods in storage. For best results, pumps can be retained in storage, as factory assembled, in a dry atmosphere with constant temperatures for up to six (6) months.

**Long Term** - Any length of time exceeding six (6) months, but not more than twenty four (24) months. The units should be stored in a temperature controlled area, a roofed over walled enclosure that provides protection from the elements (rain, snow, wind blown dust, etc.), and whose temperature can be maintained between +40 deg. F and +120 deg. F.

If extended high humidity is expected to be a problem, all exposed parts should be inspected before storage and all surfaces that have the paint scratched, damaged, or worn should be recoated with a water base, air dry enamel paint. All surfaces should then be sprayed with a rust-inhibiting oil.

### Service Centers:

For the location of the nearest Burks Service Center, check your Burks representative or Crane Pumps & Systems, Inc., in Piqua, Ohio, telephone (937) 778-8947.

## INSTALLATION

Pump should be installed in a clean dry area on a solid surface. It does not necessarily need to be bolted down. New pipe of proper size to minimize friction losses should be used on the suction and discharge of the pump. All pipe joints must be air tight.

Provision must be made in discharge piping to permit priming. Piping to both suction and discharge of the pump must be properly supported in order to insure there are no pipe strains or stresses brought to bear on the pump.

A check valve or foot valve is not necessary in the suction piping except to maintain the system full of liquid. Where there is a long, horizontal run in the suction piping, or a vertical suction lift of 25 feet (15 feet with WPT5, 10 feet with WT3A, 6 feet with WPT3A) it is advisable to install a foot valve on the suction pipe.

NOTE: Maximum inlet pressure WTX, WPTX and WSTX Pumps - 15 PSIWT, WPT and WST Pumps - 100 PSI



**WARNING: A faulty motor or wiring can be a serious electrical shock hazard if it or surrounding water are accessible to human contact. To avoid this danger, connect the motor frame to the power supply grounding terminal with copper conductor no smaller than the circuit conductors. In all installations connect above ground metal plumbing to the power supply ground per National Code Article 250-80 to prevent electrical shock hazard.**

Electrical connections to the motor should be made by competent electrician. Wiring diagrams shown on the motor nameplate should be followed for connecting power supply. Electrical characteristics of supply power must be the same as that shown on the motor nameplate. A fuse switch should be installed in the circuit leading to the pump motor. In wiring 3 phase motors, make sure the shaft rotation is clockwise when looking at the motor end of the pump.

### OVERLOAD PROTECTION:

All 56 frame, single phase motors, open drip proof, totally enclosed and explosion proof have built-in overload protection. All three phase motors must be installed with a magnetic starter which provides a 3-leg protection for the motor. Failure to use the correct starter and heater coils will void warranty.

## OPERATION



**IMPORTANT Pump Must Be Primed On Initial Start-Up**

Prime the pump by filling the pump case with clean water. Close disconnect switch to start pump.

## MAINTENANCE

### LUBRICATION:

No lubrication is required for the liquid end of the pump.

Dual voltage motors, 1/3 thru 3 Hp are equipped with ball bearings at both ends which are grease packed and sealed at the factory. No further lubrication is required. 1/3 Hp, 115 Volt only, motors have ball/sleeve bearing construction. The ball bearing at the pump end requires no lubrication. The opposite end of the motor has a sleeve type bearing which may be lubricated periodically by removing the cap and saturating wick material with SAE 10 oil.

### SHAFT SEAL:

The mechanical shaft seal should be replaced if liquid is noticed around the motor shaft. Remove case and impeller. Using two screw drivers to pry on each side, remove seal stationary seat. Clean seat area of frame, install new stationary seat with ceramic surface facing out and slide new rotating element over shaft with hard carbon surface against ceramic seat. Be sure to keep all surfaces clean. Lubricating seal parts with water will help the installation of the seal. Reinstall impeller and pump case.

**DRAINING THE PUMP:**

To drain pump, remove 1/2" pipe plug from bottom of pump case. After pump has drained, start pump to discharge liquid from impeller. Always protect the pump, piping, etc., from freezing - or drain the system when there is a chance of freeze-up.

**MOTOR:**

Keep motor clean and dry. It is drip-proof when installed horizontally and the windings are protected from excess humidity, but extreme conditions should be avoided when possible. If motor fails to run, be sure power is on, all switches or electrical controls are closed, fuses are in order and all electrical controls are tight. (Motor must be repaired by Authorized Repair Station under terms of warranty.)

**BARNES**<sup>®</sup>

**BARNES**<sup>®</sup>  
PRESSURE **PS** SYSTEMS



**burks**<sup>®</sup>

**WEINMAN**<sup>®</sup>

**DEMING**<sup>®</sup>

**PROSSER**<sup>®</sup>

## *Limited 24 Month Warranty*

Crane Pumps & Systems warrants that products of our manufacture will be free of defects in material and workmanship under normal use and service for twenty-four (24) months after manufacture date, when installed and maintained in accordance with our instructions. This warranty gives you specific legal rights, and there may also be other rights which vary from state to state. In the event the product is covered by the Federal Consumer Product Warranties Law (1) the duration of any implied warranties associated with the product by virtue of said law is limited to the same duration as stated herein, (2) this warranty is a LIMITED WARRANTY, and (3) no claims of any nature whatsoever shall be made against us, until the ultimate consumer, his successor, or assigns, notifies us in writing of the defect, and delivers the product and/or defective part(s) freight prepaid to our factory or nearest authorized service station. Some states do not allow limitations on how long an implied warranty lasts, so the above limitation may not apply. **THE SOLE AND EXCLUSIVE REMEDY FOR BREACH OF ANY AND ALL WARRANTIES WITH RESPECT TO ANY PRODUCT SHALL BE TO REPLACE OR REPAIR AT OUR ELECTION, F.O.B. POINT OF MANUFACTURE OR AUTHORIZED REPAIR STATION, SUCH PRODUCTS AND/OR PARTS AS PROVEN DEFECTIVE. THERE SHALL BE NO FURTHER LIABILITY, WHETHER BASED ON WARRANTY, NEGLIGENCE OR OTHERWISE.** Unless expressly stated otherwise, guarantees in the nature of performance specifications furnished in addition to the foregoing material and workmanship warranties on a product manufactured by us, if any, are subject to laboratory tests corrected for field performance. Any additional guarantees, in the nature of performance specifications must be in writing and such writing must be signed by our authorized representative. Due to inaccuracies in field testing if a conflict arises between the results of field testing conducted by or for user, and laboratory tests corrected for field performance, the latter shall control. **RECOMMENDATIONS FOR SPECIAL APPLICATIONS OR THOSE RESULTING FROM SYSTEMS ANALYSES AND EVALUATIONS WE CONDUCT WILL BE BASED ON OUR BEST AVAILABLE EXPERIENCE AND PUBLISHED INDUSTRY INFORMATION. SUCH RECOMMENDATIONS DO NOT CONSTITUTE A WARRANTY OF SATISFACTORY PERFORMANCE AND NO SUCH WARRANTY IS GIVEN.**

This warranty shall not apply when damage is caused by (a) improper installation, (b) improper voltage (c) lightning (d) excessive sand or other abrasive material (e) scale or corrosion build-up due to excessive chemical content. Any modification of the original equipment will also void the warranty. We will not be responsible for loss, damage or labor cost due to interruption of service caused by defective parts. Neither will we accept charges incurred by others without our prior written approval.

This warranty is void if our inspection reveals the product was used in a manner inconsistent with normal industry practice and/or our specific recommendations. The purchaser is responsible for communication of all necessary information regarding the application and use of the product. **UNDER NO CIRCUMSTANCES WILL WE BE RESPONSIBLE FOR ANY OTHER DIRECT OR CONSEQUENTIAL DAMAGES, INCLUDING BUT NOT LIMITED TO TRAVEL EXPENSES, RENTED EQUIPMENT, OUTSIDE CONTRACTOR FEES, UNAUTHORIZED REPAIR SHOP EXPENSES, LOST PROFITS, LOST INCOME, LABOR CHARGES, DELAYS IN PRODUCTION, IDLE PRODUCTION, WHICH DAMAGES ARE CAUSED BY ANY DEFECTS IN MATERIAL AND/OR WORKMANSHIP AND/OR DAMAGE OR DELAYS IN SHIPMENT. THIS WARRANTY IS EXPRESSLY IN LIEU OF ANY OTHER EXPRESS OR IMPLIED WARRANTY, INCLUDING ANY WARRANTY OF MERCHANTABILITY OR FITNESS FOR A PARTICULAR PURPOSE.**

No rights extended under this warranty shall be assigned to any other person, whether by operation of law or otherwise, without our prior written approval.

**CRANE**<sup>®</sup>

A Crane Co. Company

**PUMPS & SYSTEMS**

420 Third Street  
Piqua, Ohio 45356  
Phone: (937) 778-8947  
Fax: (937) 773-7157  
www.cranepumps.com

83 West Drive, Brampton  
Ontario, Canada L6T 2J6  
Phone: (905) 457-6223  
Fax: (905) 457-2650

**IMPORTANT!  
WARRANTY REGISTRATION**

Your product is covered by the enclosed Warranty.  
To complete the Warranty Registration Form go to:

<http://www.cranepumps.com/ProductRegistration/>

If you have a claim under the provision of the warranty, contact your local  
Crane Pumps & Systems, Inc. Distributor.

**RETURNED GOODS**

**RETURN OF MERCHANDISE REQUIRES A "RETURNED GOODS AUTHORIZATION".  
CONTACT YOUR LOCAL CRANE PUMPS & SYSTEMS, INC. DISTRIBUTOR.**



**Products Returned Must Be Cleaned, Sanitized,  
Or Decontaminated As Necessary Prior To Shipment,  
To Insure That Employees Will Not Be Exposed To Health  
Hazards In Handling Said Material. All Applicable Laws  
And Regulations Shall Apply.**