

Model FT05 Drum Pump Kit

AIR OPERATED DOUBLE DIAPHRAGM PUMPS

The FT05 drum pump kit* is ideal for transferring a wide variety of materials from drums.

- Converts 1/2" / 13mm FTI Air double diaphragm pumps to an easy-to-use drum pump.
- Easy to install
- Manufactured from corrosion resistant materials
- Unique self-adjusting intake tube automatically adjusts to sit on bottom of drum ensuring maximum transfer of fluid
- Universal NPT/BSP/Buttress bung adapter (plastic pumps) or NPT/BSP bung adapter (metal pumps) welded to mounting plate
- Stainless steel hardware



*pump sold separately

FT05 Performance

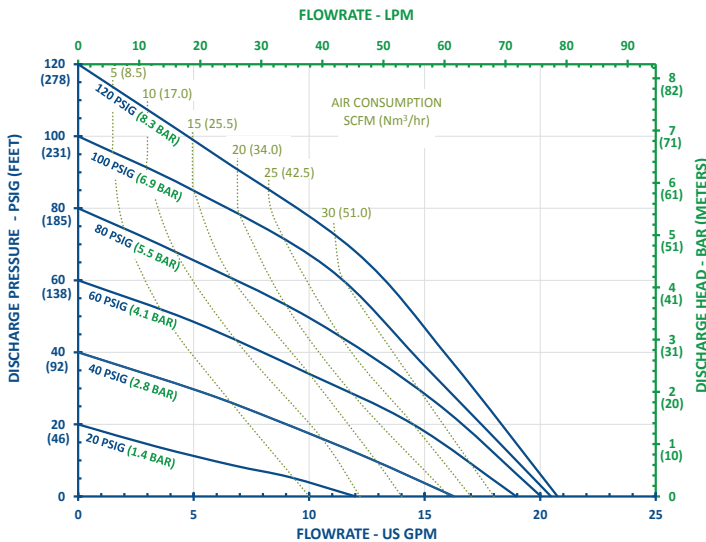

Note: Full stroke diaphragm allows performance to be equal for all elastomers.



Specifications

Suction & Discharge Size:	1/2" x 1/2"
Standard Discharge Location†:	End
Connection Types:	NPT, BSP
Air Inlet & Air Exhaust Size:	1/4" FNPT x 1/2" FNPT

†Optional NPT or BSP threaded center port location in vertical position

Pat. <http://ftiair.com/resources/ip/>

Capabilities

Maximum Flow Rate:	20 gpm (77 lpm)
Maximum Air Supply Pressure:	120 psi (8.3 bar)
Displacement Per Stroke:	0.02 gal (0.08 lit)
Minimum Air Inlet Pressure:	10 psig (0.7 bar)
Maximum Particle Size :	0.19 in (4.7 mm)
Sound Pressure:	72.1 dB(A)
Operating Temperature:	Determined by elastomers

CHANGE IS IN THE AIR

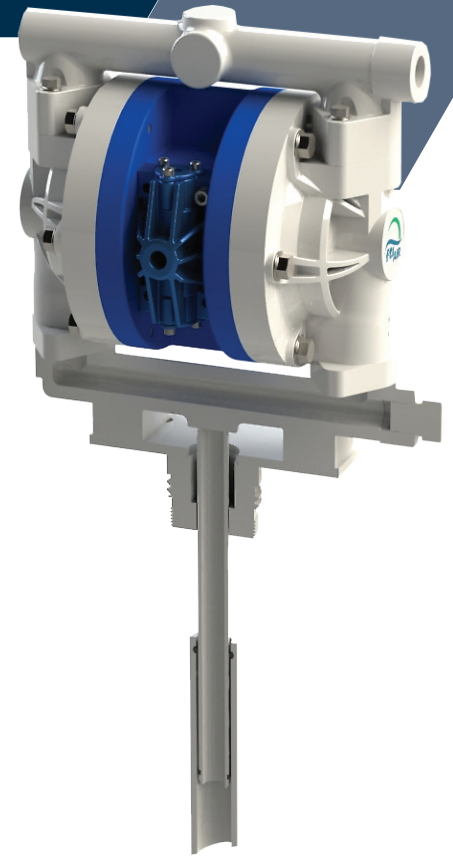

Kits

Basic Kit Part Numbers	Description	Wetted Materials
109748-3	1/2" Basic Polypropylene Drum Pump Kit	PP, PTFE, FEP
109748-4	1/2" Basic PVDF Drum Pump Kit	PVDF, PTFE, FEP
109748-5	1/2" Basic Stainless Steel Drum Pump Kit	316SS, PTFE, FEP

Retrofit Kit Part Numbers	Description	Wetted Materials
109749-3	1/2" Retrofit Polypropylene Drum Pump Kit	PP, PTFE, FEP
109749-4	1/2" Retrofit PVDF Drum Pump Kit	PVDF, PTFE, FEP
109749-5	1/2" Retrofit Stainless Steel Drum Pump Kit	316SS, PTFE, FEP
109749-6	1/2" Retrofit Aluminum Drum Pump Kit	Aluminum, 316SS, PTFE, FEP

Note: Retrofit kits include all basic kit items plus properly ported and plugged suction manifold.

Applications

- Acids & Bases
- Plating Solutions
- Wastewater & many more!

Typical Industries

- Mining
- Paints and Coatings
- Ceramics
- Pulp and Paper & many others

Non-metallic Drum Pump Kit

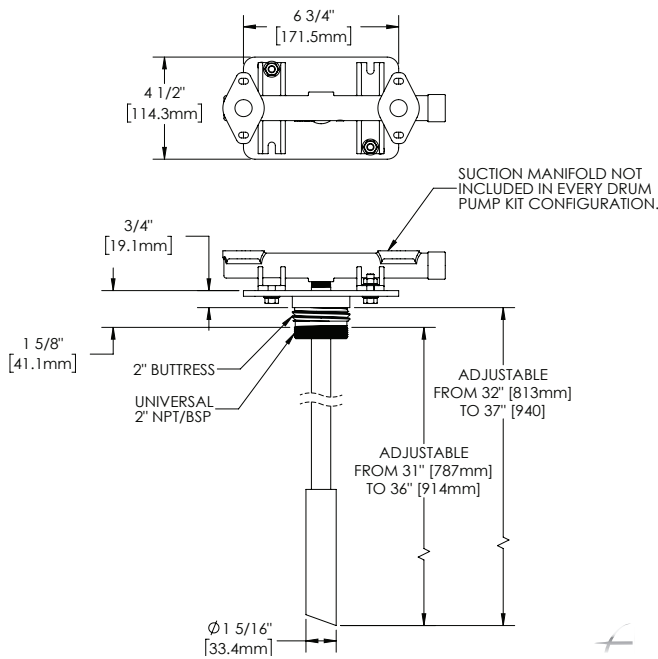

Metallic Drum Pump Kit

