



FEATURES

Impeller: Cast iron, semi-open, non-clog with pump-out vanes for mechanical seal protection. Balanced for smooth operation. Silicon bronze impeller available as an option.

Casing: Cast iron volute type for maximum efficiency. 2" NPT discharge.

Mechanical Seal: Silicon Carbide vs. Silicon Carbide sealing faces. Stainless steel metal parts, BUNA-N elastomers.

Shaft: Corrosion-resistant, stainless steel. Threaded design. Locknut on three phase models to guard against component damage on accidental reverse rotation.

Fasteners: 300 series stainless steel.

Capable of running dry without damage to components.

Designed for continuous operation when fully submerged.

WE Series

Model 3885Z 50 Hz

SUBMERSIBLE EFFLUENT PUMPS

50 Hz Wastewater

APPLICATIONS

Specifically designed for the following uses:

- Homes
- Farms
- Trailer courts
- Motels
- Schools
- Hospitals
- Industry
- Effluent systems

SPECIFICATIONS

Pump:

- Solids handling capabilities: $\frac{3}{4}$ " maximum
- Discharge size: 2" NPT (STD.)
- 2" BSPP (optional)
- Capacities: up to 120 GPM
- Total heads: up to 84 feet TDH
- Temperature:
 - 104°F (40°C) continuous
 - 140°F (60°C) intermittent.
- See order numbers on reverse side for specific HP, voltage, phase and RPM's available.

MOTORS

- Fully submerged in high-grade turbine oil for lubrication and efficient heat transfer.

Class B insulation

Single phase (50 Hz):

- Built-in overload with automatic reset.
- All single phase models feature capacitor start motors for maximum starting torque.
- $\frac{1}{3}$ and $\frac{1}{2}$ HP - 16/3 SJTOW with bare leads.
- 1-1 $\frac{1}{2}$ HP - 14/3 STOW with bare leads.

Three phase (50 Hz):

- Overload protection must be provided in starter unit.
- $\frac{1}{3}$ -1 $\frac{1}{2}$ HP - 14/4 STOW with bare leads.
- Designed for Continuous Operation: Pump ratings are within the motor manufacturer's recommended working limits, can be operated continuously without damage.
- Bearings: Upper and lower heavy duty ball bearing construction.
- Power Cable: Severe duty rated, oil and water resistant. Epoxy seal on motor end provides secondary moisture barrier in case of outer jacket damage and to prevent oil wicking. 20 foot standard with optional lengths available.
- O-ring: Assures positive sealing against contaminants and oil leakage.

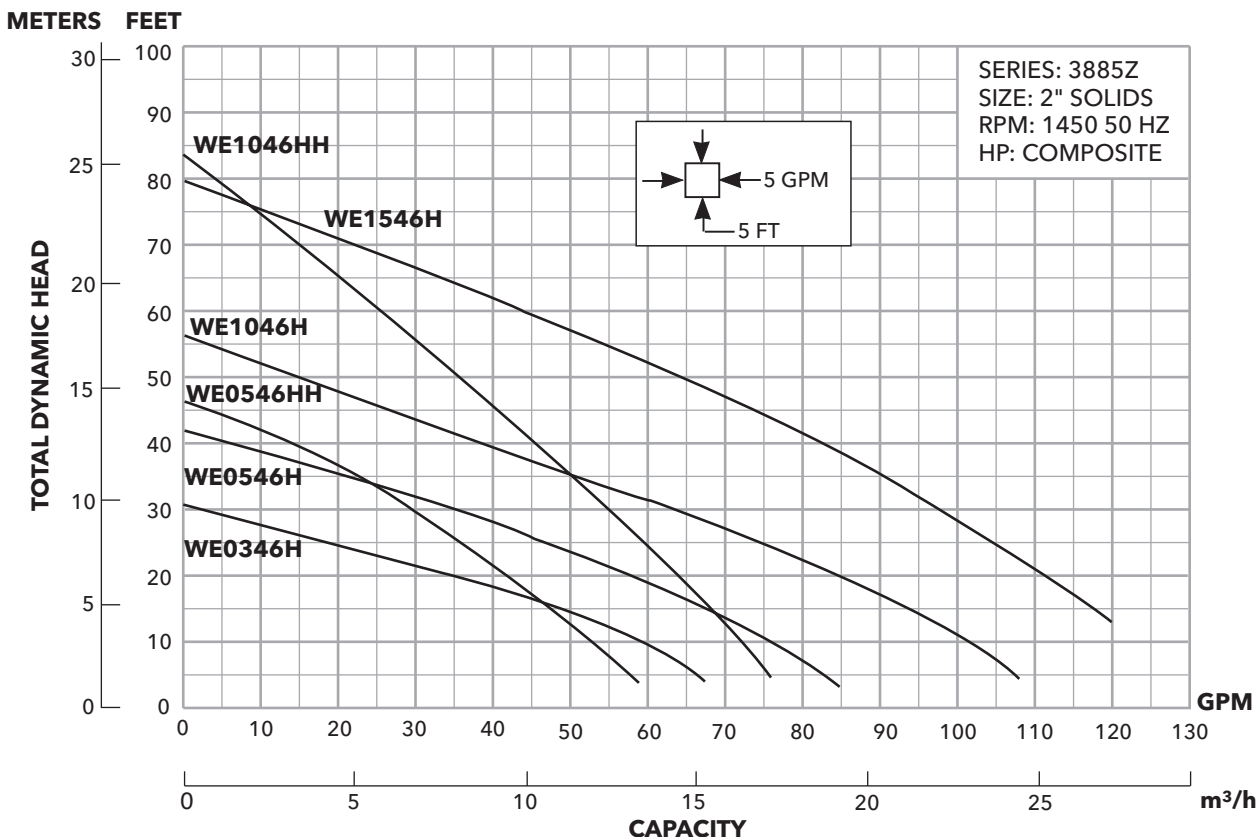

MODELS

Order Number	HP	Volts	Phase	RPM	Impeller Diameter	Maximum Amps	Weight (lbs.)
WE0321H	1/3	115	1	2900	3 7/16"	12.8	60
WE0329H		220	1			6.4	
WE0346H		380	3			1.7	
WE0521H	1/2	115	1		4 1/16"	15.0	70
WE0529H		220	1			7.5	
WE0546H		380	3			2.1	
WE1029H	1	220	1		4 7/16"	10.6	80
WE1046H		380	3			2.8	
WE1029HH	1	220	1		5 1/2"	11.1	
WE1046HH		380	3	2.6			
WE1529H	1 1/2	220	1	5 5/8"	11.6	83	
WE1546H		380	3		3.8		

Complete System Components available in the accessory section of this catalog.

DIMENSIONS

(All dimensions are in inches. Do not use for construction purposes.)

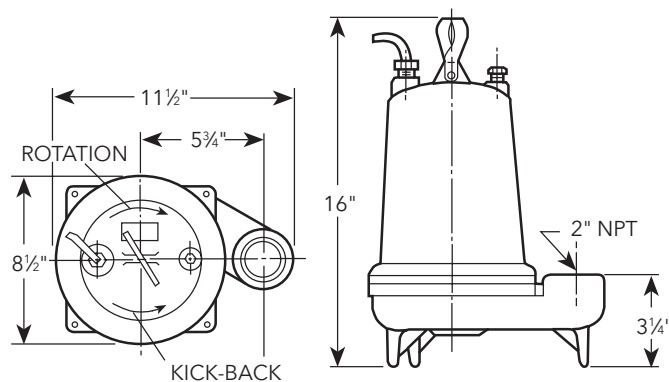

COMPONENTS FOR REFERENCE ONLY

Item No.	Description
1	Impeller
2	Casing
3	Silicon carbide vs. silicon carbide Mechanical seal
4	Shaft
5	Motor
6	Ball bearings
7	Power cable
8	O-ring

NOTE: Repair parts may be ordered from repair parts list.

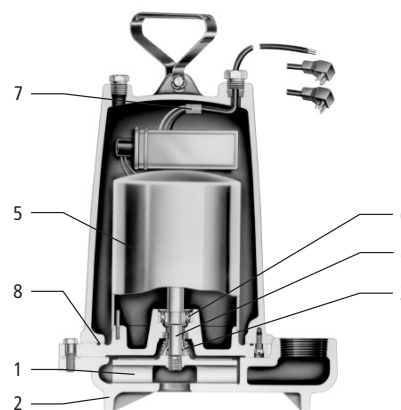

Xylem |'zīləm|

- 1) The tissue in plants that brings water upward from the roots;
- 2) a leading global water technology company.

We're 12,500 people unified in a common purpose: creating innovative solutions to meet our world's water needs. Developing new technologies that will improve the way water is used, conserved, and re-used in the future is central to our work. We move, treat, analyze, and return water to the environment, and we help people use water efficiently, in their homes, buildings, factories and farms. In more than 150 countries, we have strong, long-standing relationships with customers who know us for our powerful combination of leading product brands and applications expertise, backed by a legacy of innovation.

For more information on how Xylem can help you, go to www.xylem.com



Xylem, Inc.
2881 East Bayard Street Ext., Suite A
Seneca Falls, NY 13148
Phone: (866) 325-4210
Fax: (888) 322-5877
www.xylem.com/brands/gouldswatertechnology

Goulds is a registered trademark of Goulds Pumps, Inc. and is used under license.
© 2012 Xylem Inc. B3885Z March 2011