



FEATURES

Impeller: Cast iron, enclosed, non-clog, dynamically balanced with pump out vanes for mechanical seal protection. Optional silicon bronze impeller available.

Casing: Cast iron flanged volute type for maximum efficiency. Designed for easy installation on A10-20 slide rail or base elbow rail systems.

Mechanical Seal: SILICON CARBIDE VS. SILICON CARBIDE sealing faces for superior abrasive resistance, stainless steel metal parts, BUNA-N elastomers.

Shaft: Corrosion-resistant, 400 series stainless steel. Threaded design. Locknut on all models to guard against component damage on accidental reverse rotation.

Fasteners: 300 series stainless steel.

Capable of running dry without damage to components.

Designed for continuous operation when fully submerged.

WS_BHF Series

Model 3887ZBHF 50 Hz

SUBMERSIBLE SEWAGE PUMP



50 Hz Wastewater

APPLICATIONS

Specifically designed for the following uses:

- Homes
- Sewage systems
- Dewatering/Effluent
- Water transfer
- Light industrial
- Commercial applications

Anywhere waste or drainage must be disposed of quickly, quietly and efficiently.

SPECIFICATIONS

Pump:

- Solids handling capabilities: 2" maximum
- Capacities: up to 220 GPM
- Total heads: up to 58 feet TDH
- Discharge size: 2" NPT threaded companion flange standard. 3" option available but must be ordered separately. (Order no. A1-3)
- 2" or 3" BSPP Connection (optional)
- Temperature:
 - 104°F (40°C) continuous
 - 140°F (60°C) intermittent.
- See order numbers on reverse side for specific HP, voltage, phase and RPMs available.

MOTORS

- Fully submerged in high grade turbine oil for lubrication and efficient heat transfer. All ratings are within the working limits of the motor.
- Class B insulation
 - All single phase models feature capacitor start motors for maximum starting torque.
- Single phase (50 Hz):
 - Built-in overload with automatic reset.
 - 1/3 and 1/2 HP - 16/3 SJTOW with bare leads.
 - 3/4 to 1 1/2 HP - 14/3 STOW with bare leads.
- Three phase (50 Hz):
 - Overload protection must be provided in starter unit.
 - 1/3 and 1/2 HP - 14/4 STOW with bare leads.
- Designed for Continuous Operation: Pump ratings are within the motor manufacturer's recommended working limits, can be operated continuously without damage.
- Bearings: Upper and lower heavy duty ball bearing construction.
- Power Cable: Severe duty rated, oil and water resistant. Epoxy seal on motor end provides secondary moisture barrier in case of outer jacket damage and to prevent oil wicking. 20 foot standard with optional lengths available.
- Motor Cover O-ring: Assures positive sealing against contaminant and oil leakage.

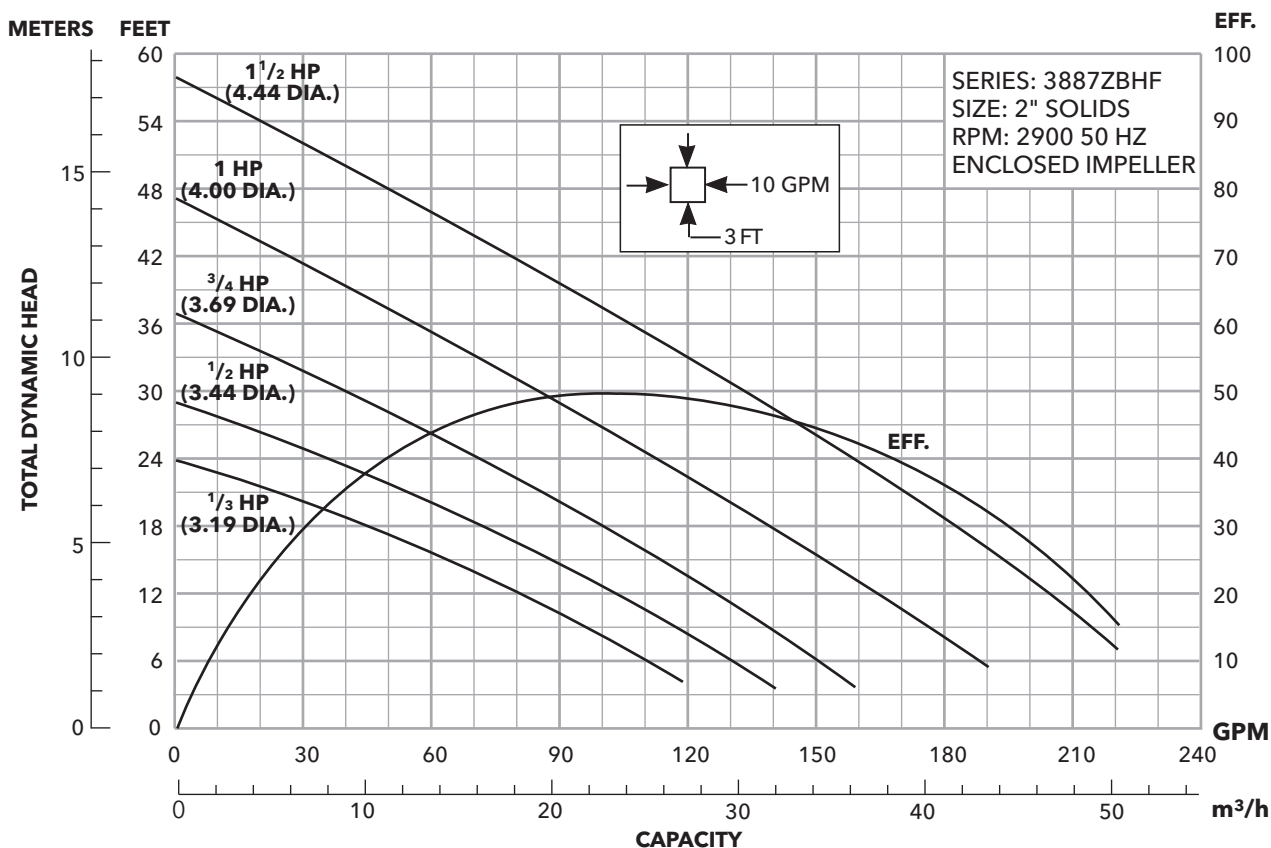

MODELS

Order Number	HP	Volts	Phase	RPM	Impeller Diameter	Maximum Amps	Weight (lbs.)
WS0329BHF	1/3	220	1	2900	3 3/16"	6.7	63
WS0346BHF		380	3			1.7	
WS0529BHF	1/2	220	1		3 7/16"	7.8	65
WS0546BHF		380	3			2.0	
WS0729BHF	3/4	220	1		3 11/16"	9.4	70
WS0746BHF		380	3			2.7	
WS1029BHF	1	220	1		4"	13.3	75
WS1046BHF		380	3			3.4	
WS1529BHF	1 1/2	220	1		4 7/16"	17.0	80
WS1546BHF		380	3			4.8	

Complete System Components available in the accessory section of this catalog.

DIMENSIONS

(All dimensions are in inches. Do not use for construction purposes.)

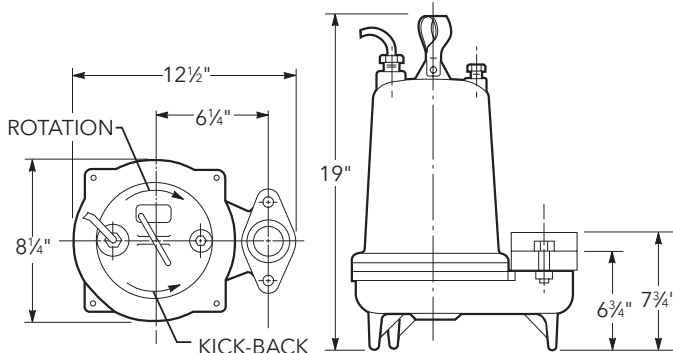

COMPONENTS FOR REFERENCE ONLY

Item No.	Description
1	Impeller
2	Casing
3	Silicon carbide vs. silicon carbide Mechanical seal
4	Shaft
5	Motor
6	Ball bearings
7	Power cable
8	O-ring

NOTE: Repair parts may be ordered from repair parts list.

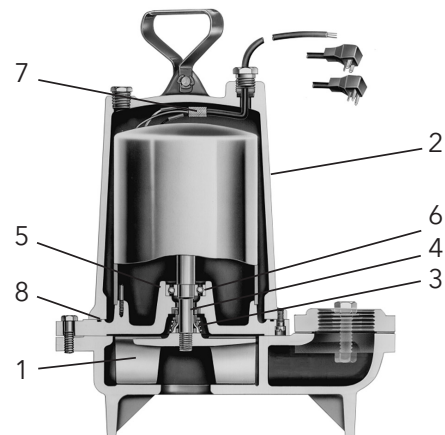

Xylem |'zīləm|

- 1) The tissue in plants that brings water upward from the roots;
- 2) a leading global water technology company.

We're a global team unified in a common purpose: creating innovative solutions to meet our world's water needs. Developing new technologies that will improve the way water is used, conserved, and re-used in the future is central to our work. We move, treat, analyze, and return water to the environment, and we help people use water efficiently, in their homes, buildings, factories and farms. In more than 150 countries, we have strong, long-standing relationships with customers who know us for our powerful combination of leading product brands and applications expertise, backed by a legacy of innovation.

For more information on how Xylem can help you, go to www.xylem.com

Order Online: www.PumpCatalog.com



Xylem Inc.
2881 East Bayard Street Ext., Suite A
Seneca Falls, NY 13148
Phone: (866) 325-4210
Fax: (888) 322-5877
www.gouldswatertechnology.com

Goulds is a registered trademark of Goulds Pumps, Inc. and is used under license.
© 2016 Xylem Inc. B3887ZBHF R1 September 2016