

SE1 and SEV pumps

Range 48, 1.5 - 15 Hp (1.1 - 11 kW) 60 Hz ANSI



1. Introduction	3	SE1.30.A30.100.4	55
Introduction	3	SE1.30.A40.20.4	57
Applications	3	SE1.30.A40.30.4	59
Smartdesign®	4	SE1.30.A40.40.4	61
2. Performance range	5	SE1.30.A40.55.4	63
Performance overview	5	SE1.30.A40.75.4	65
Performance range	6	SE1.30.A40.100.4	67
3. Identification	7	SE1.40.A40.55.4	69
Nameplate	7	SE1.40.A40.75.4	71
Type key	7	SE1.40.A40.100.4	73
4. Selection of product	8	SE1.40.A60.55.4	75
Ordering the product	8	SE1.40.A60.75.4	77
5. Product range	9	SE1.40.A60.100.4	79
6. Variants	12	SEV.25.A25.30.2.6	81
List of variants	12	SEV.25.A25.40.2.6	83
7. Construction	14	SEV.25.A25.55.2.6	85
SE1	14	SEV.25.A30.30.2.6	87
SEV	16	SEV.25.A30.40.2.6	89
Material specification	18	SEV.25.A30.55.2.6	91
8. Product description	20	SEV.30.A30.15.4.6	93
Features	20	SEV.30.A30.18.4.6	95
Operating mode	22	SEV.30.A30.20.4.6	97
Motor range	23	SEV.30.A30.30.4.6	99
Approvals	24	SEV.30.A30.55.4.6	101
Controllers	25	SEV.30.A30.80.2.6	103
Wiring diagrams	27	SEV.30.A30.100.2.6	105
9. Performance curves and technical data	30	SEV.30.A30.125.2.6	107
How to read the performance curves	30	SEV.30.A30.150.2.6	109
Curve conditions	32	SEV.30.A40.15.4.6	111
Performance tests	32	SEV.30.A40.18.4.6	113
Certificates	32	SEV.30.A40.20.4.6	115
Witness test	32	SEV.30.A40.30.4.6	117
SE1.20.A25.30.2	33	SEV.30.A40.55.4.6	119
SE1.20.A25.40.2	35	SEV.30.A40.80.2.6	121
SE1.20.A25.55.2	37	SEV.30.A40.100.2.6	123
SE1.20.A30.30.2	39	SEV.30.A40.125.2.6	125
SE1.20.A30.40.2	41	SEV.30.A40.150.2.6	127
SE1.20.A30.55.2	43	SEV.40.A40.40.4.6	129
SE1.30.A30.20.4	45	SEV.40.A40.55.4.6	131
SE1.30.A30.30.4	47	SEV.40.A40.75.4.6	133
SE1.30.A30.40.4	49	SEV.40.A40.100.4.6	135
SE1.30.A30.55.4	51	10. Accessories	137
SE1.30.A30.75.4	53	Installation systems	137
		Other accessories	141
		11. Dimensions and weights	142
		Dimensions	142
		Weights	154
		Flange forces	154
		12. Grundfos Product Center	156
		Grundfos GO	157

1. Introduction

Introduction

This data booklet deals with Grundfos SE1 and SEV submersible sewage and wastewater pumps with 1.5 - 15 hp (1.1 - 11 kW)

Two types of pumps are available:

- SE1 pumps with S-tube® impeller
- SEV pumps with SuperVortex (free-flow) impeller.



TM048007

SE1 (S-tube®) and SEV (SuperVortex) pumps

The S-tube® impeller is the only impeller available in the wastewater market that does not compromise either efficiency or free passage through the pump.

The SuperVortex or S-tube® impeller pumps are specifically designed for pumping sewage and wastewater in a wide range of municipal, private and industrial applications.

The pumps are made of wear-resistant materials, such as cast iron and stainless steel. These materials ensure long and reliable operation.

The pumps are fitted with IEC IE1 efficiency motors from 1.5 to 15 hp (1.1-11 kW). The motors are either 2- or 4-pole motors, depending on the motor size.

The free passage (spherical) in the pumps is 2 to 4 inches (50 to 100 mm), depending on the pump type. All pump housings have a cast iron, PN 10 outlet flange, 2.5" to 6".

The pumps are available for the following installation types:

- dry installation, vertical or horizontal
- submerged installation on auto-coupling system
- submerged installation, free-standing on ring stand.

Applications

Typical application is transfer of liquid including:

- wastewater with a high fiber content
- drainage and surface water
- domestic wastewater
- municipal wastewater

- industrial wastewater
- process and cooling water.

The pumps can be used in locations such as:

- municipal network pumping stations
- inlet pumping stations in wastewater treatment plants
- primary clarification pits in wastewater treatment plants
- secondary clarification pits in wastewater treatment plants
- stormwater pumping stations
- public buildings
- residential buildings
- factories and industry.

Smartdesign®

smartdesign® describes the functional design of our products that combines elegant appearance with smart features, created with customer needs in mind.

smartdesign® does not only look good; the design also makes installation, operation and maintenance of the product easier and more user-friendly.

The following **smartdesign®** features are included in the SE1 and SEV pumps:

- cooling jacket for internal cooling of the motor which makes the pumps suitable for dry and submerged installation without the need for external cooling
- moisture-proof cable plug connection made of corrosion-resistant stainless steel with conductors embedded in polyethane sealant
- stainless steel clamp connection between motor housing and pump housing for easy service
- double mechanical cartridge shaft seal for easy service and perfect seal face alignment
- power cable incorporating wires for thermal sensors in the motor windings
- no additional cable required for sensors in pumps with sensors
- monitoring of operating conditions for pumps with sensors
- moisture detector for continuous monitoring of motor enclosure and automatic cut-out in case of leakage
- heavy-duty bearings greased for life
- built for frequency converter operation
- smooth pump surface preventing dirt and impurities from sticking to the pump
- self-cleaning S-tube® impeller with a long vane reducing the risk of jamming or clogging, or SuperVortex impeller with high pumping efficiency and less downtime
- explosion-proof motors for potentially explosive environments
- motor insulation class F (155 °C)
- enclosure class IP68 with one thermal sensor in each phase.

2. Performance range

Performance overview

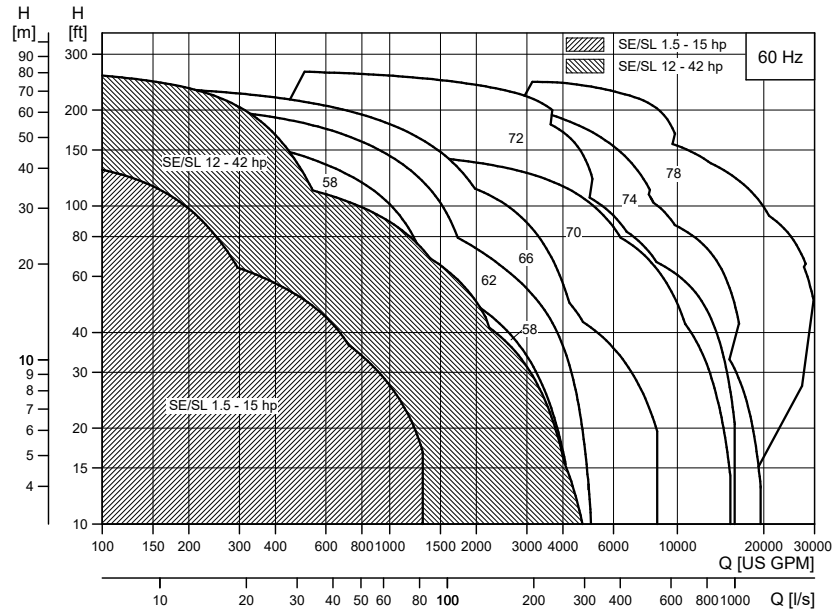

TM054845

Performance overview

Performance range

The figure below gives an overview of the various sizes and impeller types.

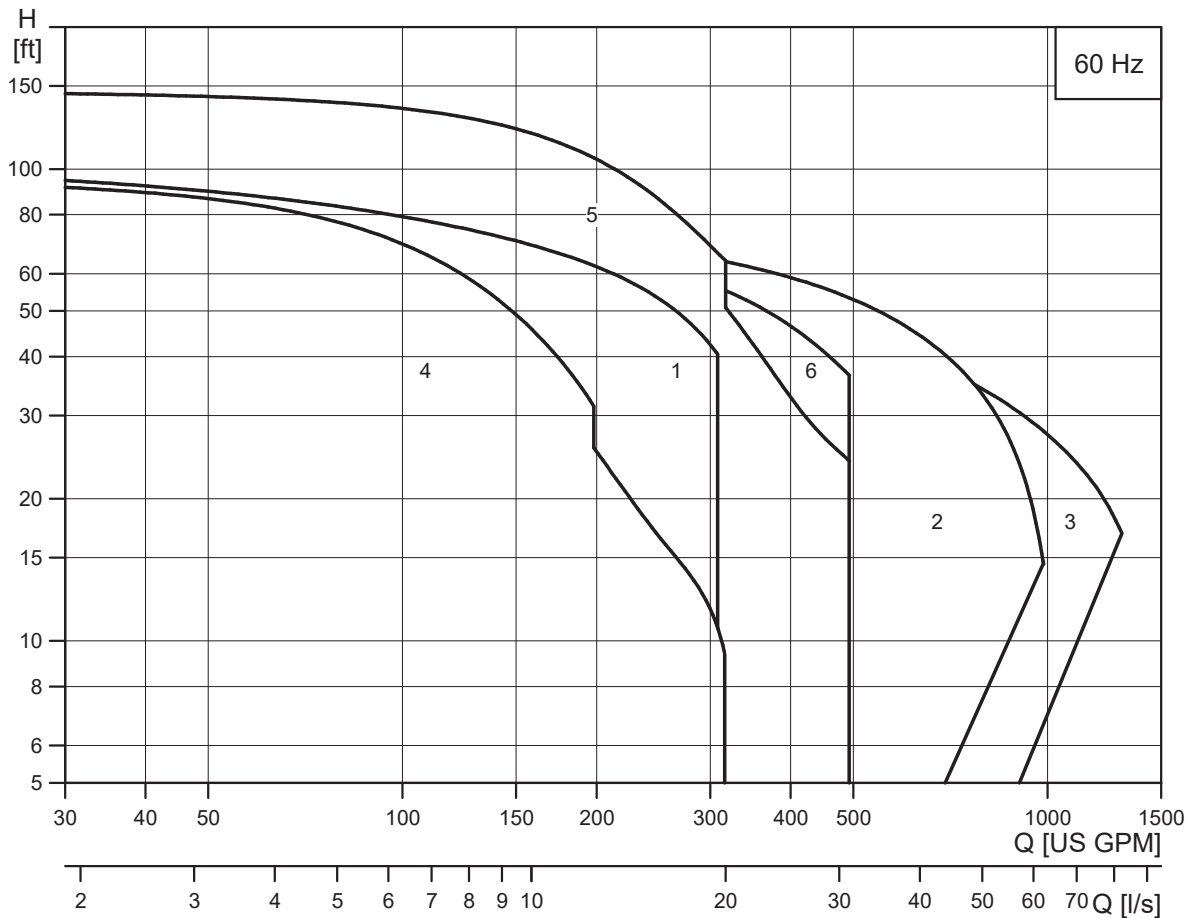

TM047578

Performance range of SE1/SEV pumps pumps

Note: For information about the performance range of each individual pump, see Performance curves and technical data. If your required duty point exceeds the gray performance range below, see the data booklets of the SL (1/V), SE (1/V) and S range in the Grundfos Product Center.

Pump type	Curve no.	Pump type	Curve no.
SE1.20.A25.30	1	SEV.25.A25.30	4
SE1.20.A25.40		SEV.25.A25.40	
SE1.20.A25.55		SEV.25.A25.55	
SE1.20.A30.30		SEV.25.A30.30	
SE1.20.A30.40		SEV.25.A30.40	
SE1.20.A30.55		SEV.25.A30.55	
SE1.30	2	SEV.30	5
SE1.40	3	SEV.40	6

3. Identification

Nameplate

The nameplate states the operating data and approvals applying to the pump. The nameplate is fitted to the side of the stator housing close to the cable entry.

Fix the extra nameplate supplied with the pump to the cable end in the controller.

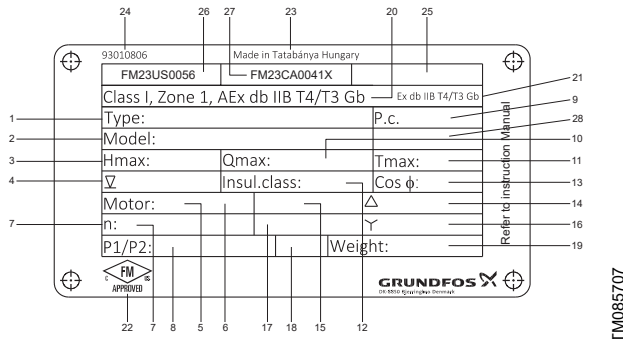

Nameplate

Pos.	Description
1	Type designation
2	Product number
3	Max. head [ft]
4	Maximum installation depth [ft]
5	Number of phases
6	Frequency [Hz]
7	Rated speed [min ⁻¹]
8	Motor input (P1) / output (P2) power [hp]
9	Production code (year and week)
10	Max. flow rate [GPM]
11	Max. liquid temperature [°F]
12	Insulation class
13	Power factor
14	Rated current [A], delta connection
15	Rated voltage [V], delta connection
16	Rated current [A], star connection
17	Rated voltage [V], star connection
18	Enclosure class
19	Net weight [lb]
20	US marking of explosion protection
21	CA marking of explosion protection
22	Mark of Approved body
23	Country of production
24	Installation and operating instructions
25	Thermal protection
26	US Explosion protection certificate number
27	CA Explosion protection certificate number
28	Ambient temperature

Type key

The pump can be identified by the type designation stated on the nameplate.

Example: **SE1.30.A40.100.A.EX.4.61R.B**

Code	Explanation	Designation
SE	Sewage and wastewater pump	Pump type
1	S-tube® impeller	Impeller type
V	SuperVortex impeller	Impeller type
30	Maximum solids size [3" (DN80)]	Pump passage
40	Nominal diameter [4" (DN100)]	Pump outlet
100	Output power P2/10	Power [10 hp (7.5 kW)]
[]	Standard (without sensor)	Sensor version
A **	Sensor version	Sensor version
[]	Non-explosion-proof pump (standard)	Pump version
Ex	Explosion-proof pump	Pump version
2	2-pole	Number of poles
4	4-pole	Number of poles
60	60 Hz	Frequency [Hz] ¹⁾
1R *	3 × 230 V / 460 V, Y direct-on-line starting	Voltage and starting method
0R *	3 × 230 V, direct-on-line starting	Voltage and starting method
0H	3 × 460 V, direct-on-line starting	Voltage and starting method
[]	First generation	Generation ²⁾
B	Second generation	Generation ²⁾
[]	Cast iron impeller, pump housing and top cover	Pump materials
Q	Stainless steel impeller, cast iron pump housing and top cover	Pump materials
R	Entire pump of stainless steel	Pump materials
D	Stainless steel	Pump materials
Z	Custom-built products	Customization

1) Maximum frequency in case of frequency-converter operation.

2) The generation code distinguishes between pumps of different design but with the same power rating.

* For 60R and 61R below the nominal level (3x230V) overload not recommended. Service Factor is 1.0

** All Explosion proof SE models are equipped with sensors

4. Selection of product

Ordering the product

When ordering a pump, take these aspects into consideration:

- pump type
- custom-built variation (optional)
- explosion-proof version
- accessories
- pump controller.

Pump type

Use the table below to identify the pump type that best fulfills your needs. The table is for guidance only.

Description	SE1	SEV
Liquid and operating characteristics		
Dry solids content up to 3 %	•	•
Dry solids content up to 5 %		•
Relatively low content of fibers and solids	•	•
Relatively high content of fibers and solids		•
Relatively low number of operating hours	•	•
Relatively high number of operating hours		•
Applications		
Stormwater	•	•
Groundwater	•	•
Drainage and surface water	•	•
Drainage and surface water with small impurities	•	•
Abrasive surface water	•	•
Wastewater with long fibers e.g. from laundries	•	•
Domestic wastewater with discharge from toilets	•	•
Municipal sewage	•	•
Sewage from commercial buildings	•	•
Industrial process water with fibers/solids		•
Industrial process water with solids	•	•
Industrial process water without solids and fibers	•	

The list below is a detailed description of the received product when this pump is ordered:

Pump	Product No
SE1.20.A25.30.A.EX.2.60R.B	93011550

- pump as specified in the type key
- 49 ft cable
- paint: NCS 9000N black (RAL 9005), gloss code 30, thickness 100 µm
- thermal switch in motor windings
- tested according to ANSI/HI 11.6:2022, grade 3B.

See section [Performance curves and technical data](#).

Note: Product-specific data for the pump can be seen in the Grundfos Product Center, using the product number 96177682.

Custom-built variants

The pumps can be customised to meet individual requirements. Many pump features and options are available for customisation, such as explosion-proof versions, various cable lengths and special materials.

Variants can be seen in the [List of variants](#) on page [List of variants](#).

For requirements or designs not included in the list, please contact Grundfos.

Explosion-proof version

The entire range is available in explosion-proof versions.

Accessories

Depending on installation type and pump variant, accessories may need to be ordered. See [Accessories](#).

Note: Ordered accessories are not factory-fitted.

Control options

The following Grundfos pump controllers are available:

- Grundfos Dedicated Controls (DC)
- Grundfos LC controllers.

The Grundfos Dedicated Controls is a control system designed for installation in either commercial buildings or network pumping stations with one to six pumps.

As standard, the system is supplied with application-optimized software and can be configured to meet specific pumping needs.

5. Product range

SE1, Cast-iron impeller, pump housing and top cover

Pump type	Number of poles	Voltage [V]		
		3 x 230V / 460 V	3 x 230V	3 x 460V
		Y/DOL	DOL	DOL
		[1R]	[0R]	[0H]
SE1.20.A25.30	2		93011550	93011551
SE1.20.A25.40	2		93011552	93011554
SE1.20.A25.55	2	93011555		
SE1.20.A30.30	2		93011556	93011557
SE1.20.A30.40	2		93011558	93011559
SE1.20.A30.55	2	93011560		
SE1.30.A30.20	4		93011561	93011562
SE1.30.A30.30	4		93011563	93011564
SE1.30.A30.40	4	93011565		
SE1.30.A30.55	4	93011566		
SE1.30.A30.75	4	93011567		
SE1.30.A30.100	4	93011568		
SE1.30.A40.20	4		93011569	93011570
SE1.30.A40.30	4		93011571	93011572
SE1.30.A40.40	4	93011573		
SE1.30.A40.55	4	93011574		
SE1.30.A40.75	4	93011575		
SE1.30.A40.100	4	93011576		
SE1.40.A40.55	4	93011577		
SE1.40.A40.75	4	93011578		
SE1.40.A40.100	4	93011579		
SE1.40.A60.55	4	93011580		
SE1.40.A60.75	4	93011581		
SE1.40.A60.100	4	93011582		

SE1, stainless steel impeller, cast-iron pump housing and top cover (Q variant)

Pump type	Number of poles	Voltage [V]		
		3 x 230V / 460 V	3 x 230V	3 x 460V
		Y/DOL	DOL	DOL
		[1R]	[0R]	[0H]
SE1.20.A25.30	2		93082882	93082883
SE1.20.A25.40	2		93082884	93082885
SE1.20.A25.55	2	93082886		
SE1.20.A30.30	2		93082887	93082888
SE1.20.A30.40	2		93082889	93082890
SE1.20.A30.55	2	93082891		
SE1.30.A30.20	4		93082892	93082893
SE1.30.A30.30	4		93082894	93082895
SE1.30.A30.40	4	93082896		
SE1.30.A30.55	4	93082897		
SE1.30.A30.75	4	93082898		
SE1.30.A30.100	4	93082899		
SE1.30.A40.20	4		93082901	93082902

Pump type	Number of poles	Voltage [V]		
		3 x 230V / 460 V	3 x 230V	3 x 460V
		Y/DOL	DOL	DOL
		[1R]	[0R]	[0H]
SE1.30.A40.30	4		93082903	93082904
SE1.30.A40.40	4	93082905		
SE1.30.A40.55	4	93082906		
SE1.30.A40.75	4	93082907		
SE1.30.A40.100	4	93082908		
SE1.40.A40.55	4	93082909		
SE1.40.A40.75	4	93082910		
SE1.40.A40.100	4	93082911		
SE1.40.A60.55	4	93082912		
SE1.40.A60.75	4	93082913		
SE1.40.A60.100	4	93082914		

SEV, Cast-iron impeller, pump housing and top cover

Pump type	Number of poles	Voltage [V]		
		3 x 230V / 460 V	3 x 230V	3 x 460V
		Y/DOL	DOL	DOL
		[1R]	[0R]	[0H]
SEV.25.A25.30	2		93011583	93011584
SEV.25.A25.40	2		93011585	93011586
SEV.25.A25.55	2	93011587		
SEV.25.A30.30	2		93011588	93011589
SEV.25.A30.40	2		93011590	93011591
SEV.25.A30.55	2	93011592		
SEV.30.A30.15	4		93011593	93011594
SEV.30.A30.18	4		93011595	93011596
SEV.30.A30.20	4		93011597	93011598
SEV.30.A30.30	4		93011599	93011600
SEV.30.A30.55	4	93011601		
SEV.30.A30.80	2	93011602		
SEV.30.A30.100	2	93011603		
SEV.30.A30.125	2	93011604		
SEV.30.A30.150	2	93011605		
SEV.30.A40.15	4		93011606	93011607
SEV.30.A40.18	4		93011608	93011609
SEV.30.A40.20	4		93011610	93011611
SEV.30.A40.30	4		93011612	93011613
SEV.30.A40.55	4	93011614		
SEV.30.A40.80	2	93011615		
SEV.30.A40.100	2	93011616		
SEV.30.A40.125	2	93011617		
SEV.30.A40.150	2	93011618		
SEV.40.A40.40	4	93011619		
SEV.40.A40.55	4	93011620		
SEV.40.A40.75	4	93011621		
SEV.40.A40.100	4	93011622		

SEV, stainless steel impeller, cast-iron pump housing and top cover (Q variant)

Pump type	Number of poles	Voltage [V]		
		3 x 230V / 460 V		
		Y/DOL	3 x 230V	3 x 460V
		[1R]	DOL [0R]	DOL [0H]
SEV.25.A25.30	2		93082915	93082916
SEV.25.A25.40	2		93082917	93082918
SEV.25.A25.55	2	93082919		
SEV.25.A30.30	2		93082920	93082921
SEV.25.A30.40	2		93082922	93082923
SEV.25.A30.55	2	93082924		
SEV.30.A30.15	4		93082925	93082926
SEV.30.A30.18	4		93082927	93082928
SEV.30.A30.20	4		93082929	93082930
SEV.30.A30.30	4		93082931	93082932
SEV.30.A30.55	4	93082933		
SEV.30.A30.80	2	93082934		
SEV.30.A30.100	2	93082935		
SEV.30.A30.125	2	93082936		
SEV.30.A30.150	2	93082937		
SEV.30.A40.15	4		93082938	93082939
SEV.30.A40.18	4		93082940	93082941
SEV.30.A40.20	4		93082943	93082944
SEV.30.A40.30	4		93082945	93082946
SEV.30.A40.55	4	93082947		
SEV.30.A40.80	2	93082948		
SEV.30.A40.100	2	93082949		
SEV.30.A40.125	2	93082950		
SEV.30.A40.150	2	93082951		
SEV.40.A40.40	4	93082952		
SEV.40.A40.55	4	93082953		
SEV.40.A40.75	4	93082954		
SEV.40.A40.100	4	93082955		

6. Variants

List of variants

Motor		
Various cable lengths	Note: When you use a cable length different from the standard length, calculate a new cable cross section.	49 ft
		65 ft
		82 ft
		98 ft
		131 ft
		164 ft
		32 ft
EMC power cables	Screened power cables designed for frequency converter operation	49 ft
		65 ft
		82 ft
		98 ft
		131 ft
		164 ft

Tests

Note: Specify all requests regarding the testing when you order the pump.

Test at specified duty on standard impeller curve

Trimmed impeller for specified duty test³⁾

Additional test of entire QH curve (including report)	5-10 duty points from the pump performance curve	
Different test standard	Efficiency guaranteed by Grundfos	AISI HI 11.6:2022, grade 1B tolerance
		AISI HI 11.6:2022, grade 2B tolerance
Customer-requested duty point	Test according to the customer-specified duty point on standard pump curve. Contact Grundfos.	AISI HI 11.6:2022, grades 1 and 2 tolerances
Vibration test (including report)	According to the Grundfos factory quality standard	
String test	Contact Grundfos.	
Witness test	Contact Grundfos.	

³⁾ SEV impellers can be trimmed on request.

Certificates

ATEX-approved pump report	Special Grundfos report. Contact Grundfos.	
Certificate of compliance with order	According to EN10204 2.1	According to ANSI HI 11.6:2022, grades 1, 2 and 3B.
Pump certificate	According to EN10204 2.2	According to ANSI HI 11.6:2022, grades 1, 2 and 3B.
Inspection certificate	According to EN10204 3.1	According to ANSI HI 11.6:2022, grades 1, 2 and 3B.
Material specification report	According to EN10204 3.1B	
Material report with certificate	According to EN10204 3.2	Material supplier information
Inspection certificate, Lloyds Register	According to EN10204 3.2	
Inspection certificate, Germanischer Lloyd	According to EN10204 3.2	
Inspection certificate, American Bureau of Shipping	According to EN10204 3.2	
Inspection certificate, Bureau Veritas	According to EN10204 3.2	
Registro Italiano Navale Agenture	According to EN10204 3.2	
Other third-party test certificates	Contact Grundfos.	

Miscellaneous		
Solution	Customer benefits	
FKM sealing (optional)	Resistant to acids	Contact Grundfos.
	Resistant to mineral oils and vegetable oils	
	Resistant to most solvents (toluene, petrol, trichloroethylene)	
Cable protection hose	Resistant to acids	Contact Grundfos.
	Resistant to most oils	
	Resistant to most solvents	
Heavy-duty wear ring kit	Wear and seal ring kit for the handling of abrasive media	Contact Grundfos.
	Increased wear resistance of impeller in abrasive applications	
	Increased reliability and life of pump	
Aluminum anodes	Increased life of pumps in aggressive environments such as maritime applications	Contact Grundfos.
	Increased corrosion resistance	
Stainless steel SuperVortex impeller according to EN 1.4517	Increased wear resistance	Contact Grundfos.
Ceramic coating of impeller and pump housing	Reduced wear rate of cast-iron parts	Contact Grundfos.
	Increased corrosion resistance	
	Beneficial in case of low number of operating hours	
Extra epoxy coating, 300 µm		Contact Grundfos.
Top coating (black RAL9005, red RAL3000 and other colors)		Contact Grundfos.
Special packaging		Contact Grundfos.
Special nameplate		Contact Grundfos.
Other variants		Contact Grundfos.

7. Construction

SE1

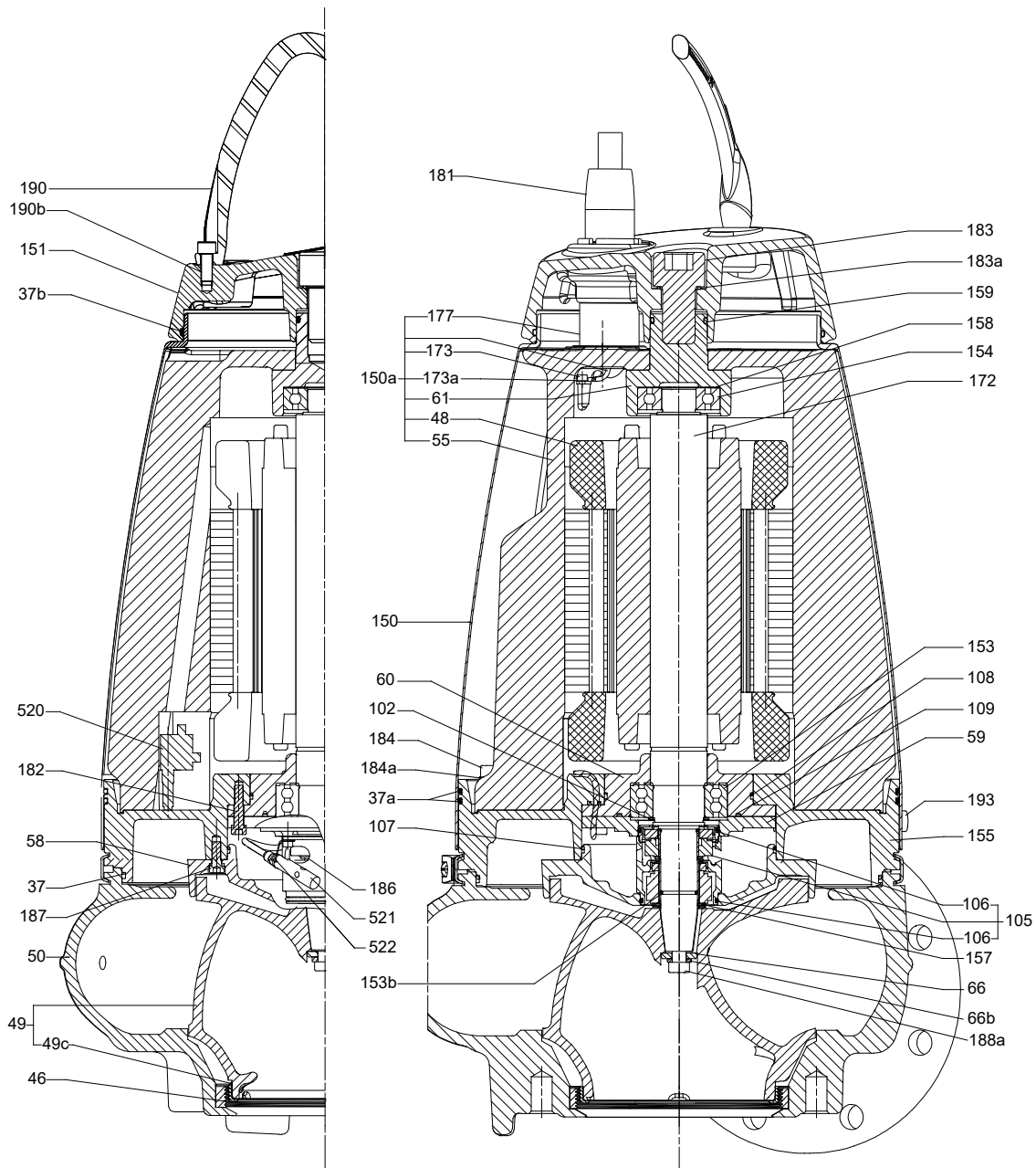

TM031520

Sectional drawing, SE1 pump with S-tube[®] impeller, sensor version

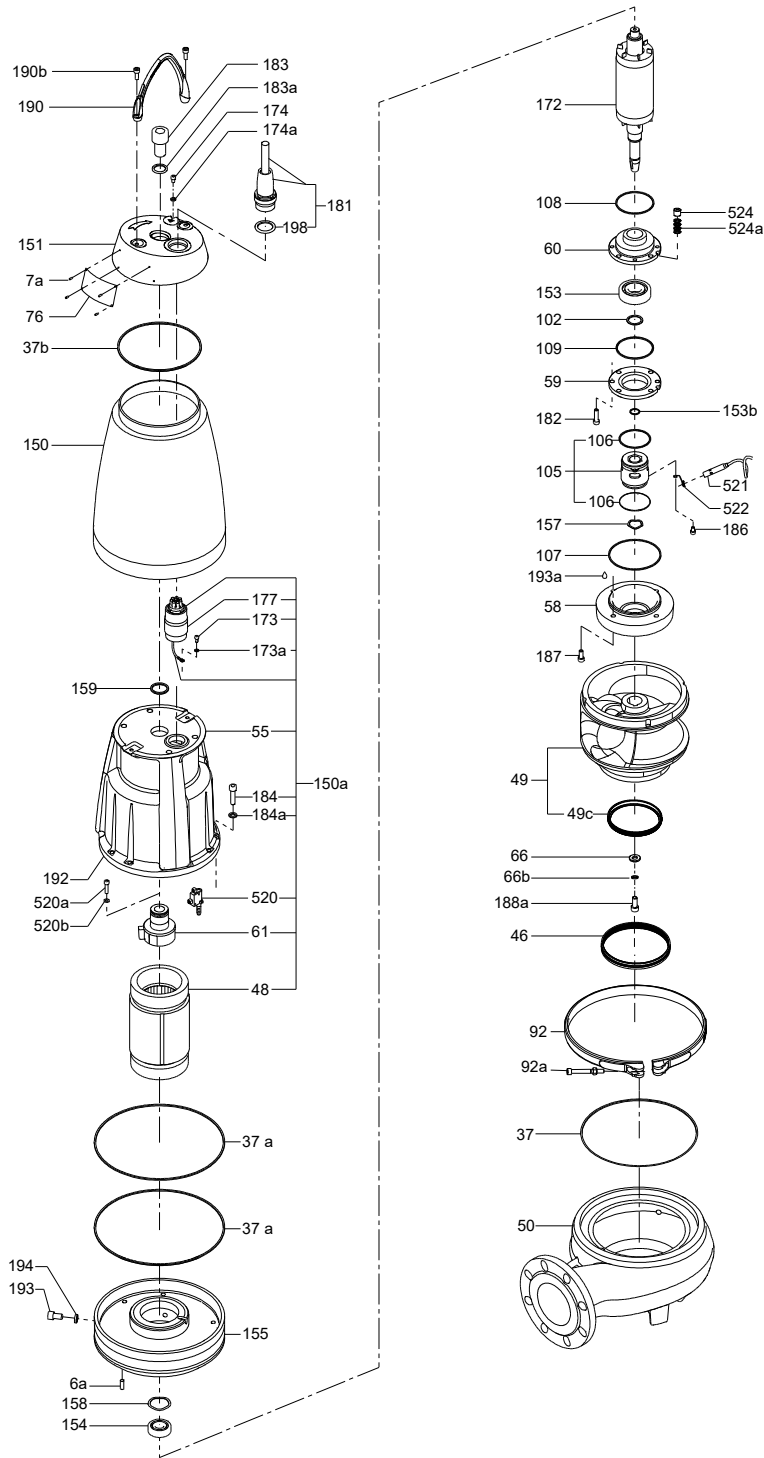

Exploded view, SE1 pump with S-tube® impeller, sensor version

TM065986

SEV

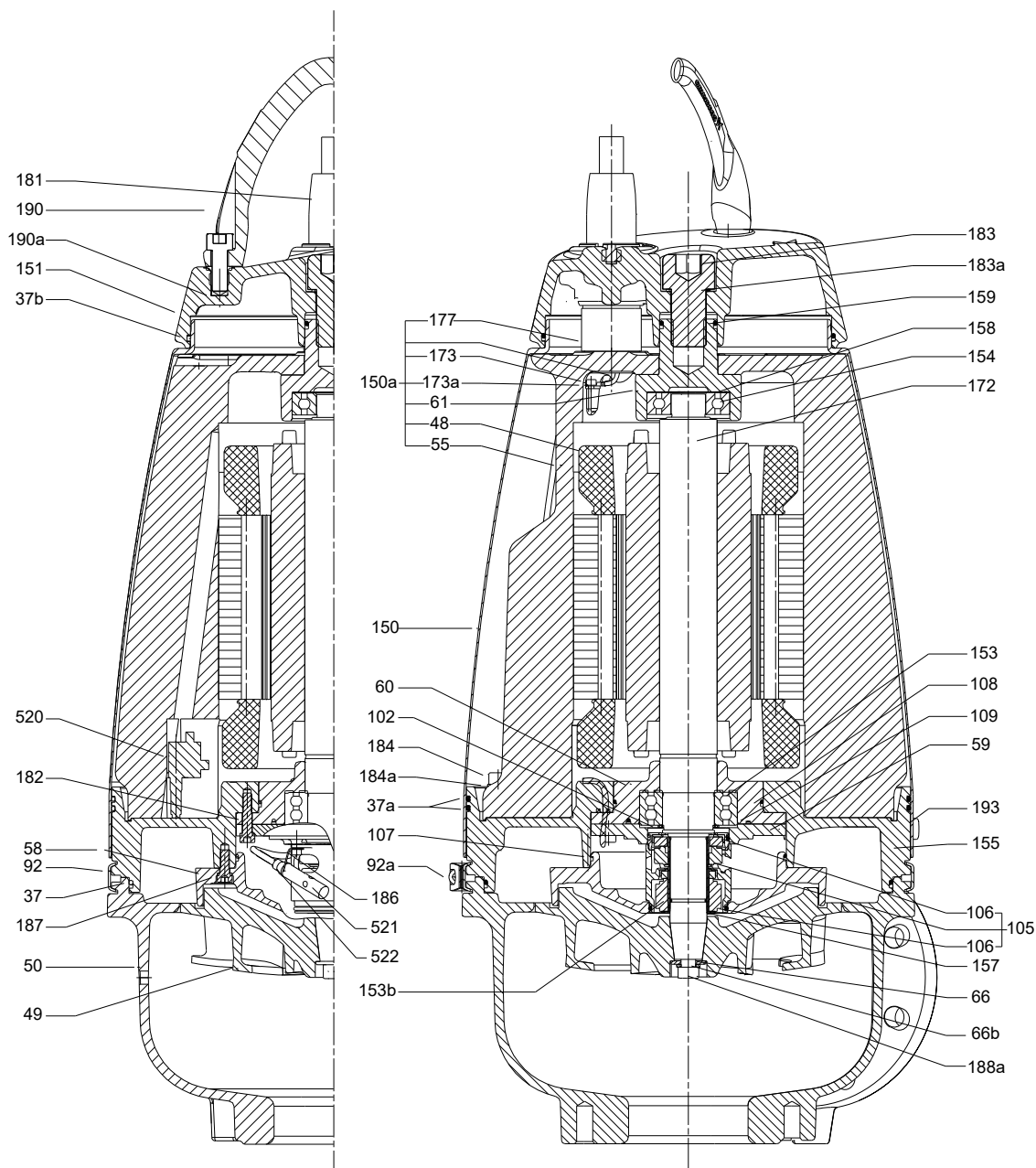

Sectional drawing, SEV pump with SuperVortex impeller, sensor version

TM031519

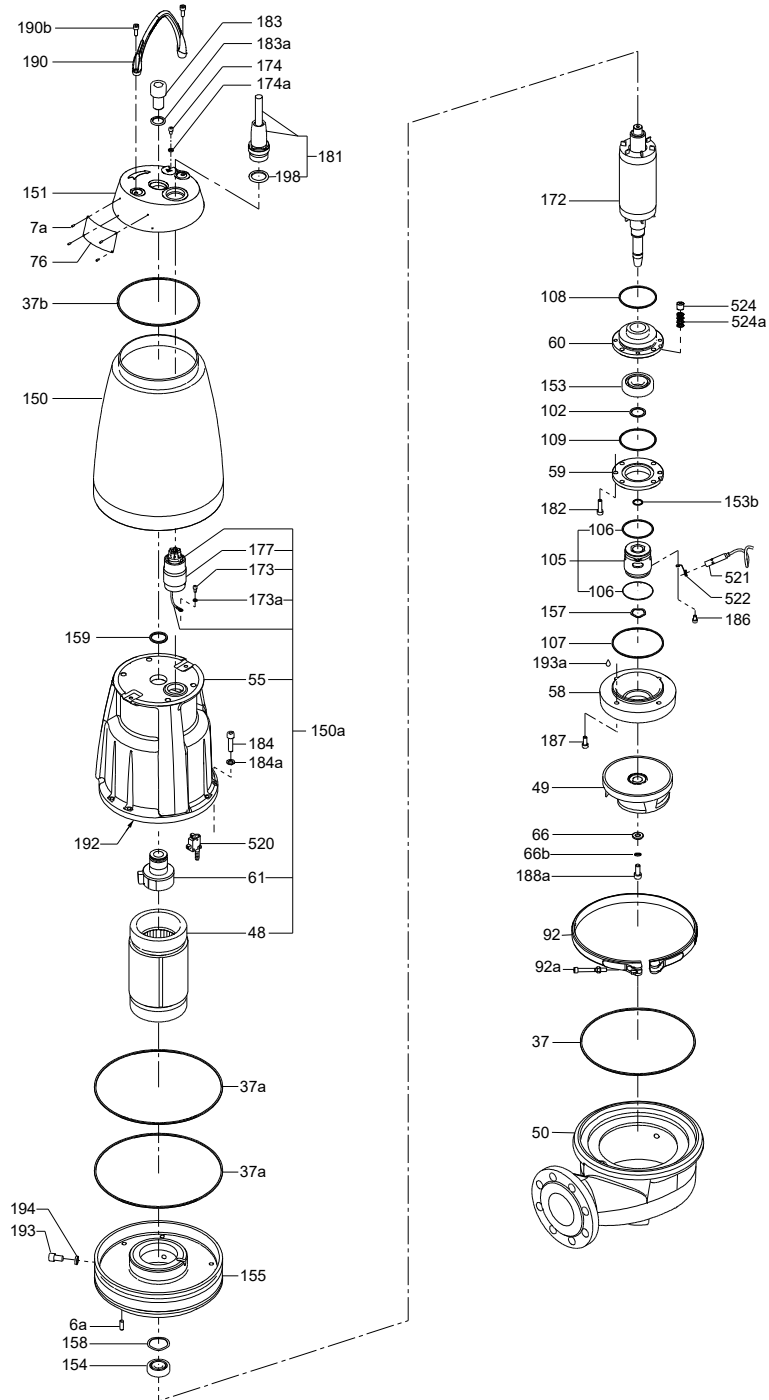

Exploded view, SEV pump with SuperVortex impeller, sensor version

TM065993

Material specification

Standard variant (cast iron)

Material declaration:

Pos.	Designation	Material	DIN W.-Nr./ EN standard
6a	Tubular pin	Stainless steel	EN 1.4301
7	Lock washer	Stainless steel	EN 1.4401
7a	Blank rivet	Stainless steel	EN 1.4301
37	O-ring	NBR rubber	
37a	O-ring	NBR rubber	
37b	O-ring	NBR rubber	
46	Seal ring, inlet	Stainless steel	EN 1.4301
48	Stator package		
49	SuperVortex impeller	Cast iron	EN-GJL-250/
	S-tube® impeller	Cast iron	EN-GJL-250
49c	Wear ring	Stainless steel	EN 1.4301
50	Pump housing	Cast iron	EN-GJL-250
55	Stator housing	Aluminium	EN AB-AISI 10 Mg
58	Cover for oil chamber	Cast iron	EN-GJL-250
59	Bearing cover	Cast iron	EN-GJL-250
60	Bearing retainer, lower	Cast iron	EN-GJL-250
61	Bearing retainer, upper	Cast iron	EN-GJS-450-10
66	Washer	Stainless steel	EN 1.4305
76	Nameplate	Stainless steel	EN 1.4301
92	Clamp	Stainless steel	EN 1.4401
92a	Screw	Stainless steel	EN 1.4401
102	Retaining ring		DIN 471
105	Shaft seal complete	Primary seal	SiC/SiC
		Housing	Stainless steel
		Secondary seal	Carbon/ceramics
106	O-ring	NBR rubber	
107	O-ring	NBR rubber	
108	O-ring	NBR rubber	
109	O-ring	NBR rubber	
150	Sleeve	Stainless steel	EN 1.4301
150a	Stator housing complete		
151	Motor top	Cast iron	EN-GJL-250
153	Ball bearing, lower	6306.2CS.C4	
153b	O-ring	NBR rubber	
154	Ball bearing, upper	6304.2Z.C3	
155	Intermediate flange	Cast iron	EN-GJL-250
157	Corrugated spring	Carbon steel	Inconel X750
158	Corrugated spring	Stainless steel	EN 1.1248
159	O-ring	NBR rubber	
172	Shaft with rotor	Non-alloy quality steel / Stainless steel	EN 1.0533/EN 1.4462
173	Earth screw	Stainless steel	EN 1.4301
173a	Lock washer	Stainless steel	EN 1.4301
174	Earth screw, external	Stainless steel	EN 1.4301
174a	Washer	Stainless steel	EN 1.4301
177	Plug protector	Stainless steel	EN 1.4408
181	Cable/outer plug part	H07RN-F / -	
182	Screw	Stainless steel	EN 1.4301
183	Screw	Stainless steel	DIN 912
183a	Washer	Copper Hard	
184	Screw	Stainless steel	DIN 912

Pos.	Designation	Material	DIN W.-Nr./ EN standard
184a	Washer	Stainless steel	
186	Screw	Stainless steel	DIN 912
188	Screw	Stainless steel	DIN 912
188a	Screw	Stainless steel	EN 1.4301
190	Lifting bracket	Stainless steel	EN 1.4301
190b	Screw		
192	Cooling paste		
193	Screw	Stainless steel	EN 1.4301
193a	Oil	Shell Ondina X420	
194	Gasket	Nylon	
198	O-ring	NBR rubber	
520	Moisture switch		
521	Water-in-oil sensor		
522	Bracket for WIO sensor		
524	Rubber bush	NBR rubber	
524a	Disc Springs		

Grey cast iron is manufactured according to EN 1561:1997.

Cast stainless steel is manufactured according to EN 10283:2010.

Conversion to other standards such as AISI/ASTM is normative, and products are not manufactured according to these.

Material variants

Position	Description	Material Variant		
		Q	R	D
	Bolts and washers	A2-70	A4-70	EN 1.4539
	O-Rings	NBR	FKM	FKM
	Polyolefin Cable Protection	No	Yes	Yes
48	Seal Ring	EN1.4301	EN1.4401	EN 1.4539
49	Impeller	EN 1.4408	EN 1.4408	EN 1.4517
49C	Wear Ring	EN 1.4301	EN 1.4401	EN 1.4539
50	Volute	EN-GJL-250	EN 1.4408	EN 1.4517
58	Cover for oil Chamber	EN-GJL-250	EN 1.4408	EN 1.4517
92	Clamp	EN 1.4401 / EN 1.4408	EN 1.4401 / EN 1.4408	EN 1.4539 / EN 1.4517
105	Shaft seal	EN 1.4408 / NBR	EN 1.4408 / FKM	EN 1.4539 / FKM
151	Motor Top	EN-GJL-250	EN 1.4408	EN 1.4517
150	Motor Sleeve	EN 1.4301	EN 1.4301	EN 1.4539
155	Intermediate flange	EN-GJL-250	EN 1.4408	EN 1.4517
157	Corrugated Spring	Inconel X750	Hastelloy C-276	Hastelloy C-276
172	Shaft with rotor	1.0533 / EN 1.4462	1.0533 / EN 1.4462	1.0533 / EN 1.4462
190	Lifting handle	EN 1.4301	EN 1.4408	EN 1.4517

8. Product description

Features

Ball bearings

The ball bearings are greased for life:

- Main bearings: Double-row angular contact ball bearing.
- Support bearings: Single-row deep-groove ball bearing.

Shaft seal



TM050015

Double mechanical cartridge shaft seal

The shaft seal consists of two mechanical seals and separates the motor from the pumped liquid.

The shaft seal is a cartridge seal that enables easy service. The combination of the primary and secondary seals in a cartridge results in a shorter assembly length compared to conventional shaft seals. The design minimises the risk of incorrect fitting.

The primary seal is SiC/SiC, while the secondary is carbon/ceramics.

Motor

The motor is watertight and completely encapsulated.

- Insulation class: F (311°F, 155 °C)
- Temperature rise class: F (221°F, 105 °C)
- Enclosure class: IP68.

For motor protection and sensors, see [Sensors](#).

Surface treatment

As surface treatment, the SE1 and SEV pumps are powder painted: NCS 9000N (black), gloss code 30, thickness 100 µm.

Power supply cables

Standard cables

Cable type	Outer cable diameter [in. (mm)]	Bending radius	
		Fixed [in. (mm)]	Free [in. (mm)]
7 G AWG 16	0.523 (13.3)	1.25 (31.8)	1.875 (47.6)
4 G AWG 14 + 3 G 16 AWG	0.636 (16.2)	1.25 (31.8)	1.875 (47.6)
7 G AWG 14 + 3 G 16 AWG	0.811 (20.6)	1.5 (38.1)	2.25 (57.2)

EMC Cable

Cable type [mm ²]	Outer cable diameter [in. (mm)]	Bending radius	
		Fixed	Free
4 G AWG 14 + 3 G 16 AWG screened cable	0.695 (17.7)	1.5 (38.1)	2.25 (57.2)

The standard cable length is 49 ft (15 m). Other cable lengths are available on request.

The number and dimension of cables depend on the motor size.

Cable entry



TM080062

Moisture-proof cable plug

The stainless steel plug is fastened with a union nut. The nut and O-rings provide sealing against liquid penetration. The plug is filled with a polyamide material which is cast into the plug around the conductors of the cable to prevent moisture from penetrating into the motor via the cable core.

Sensors

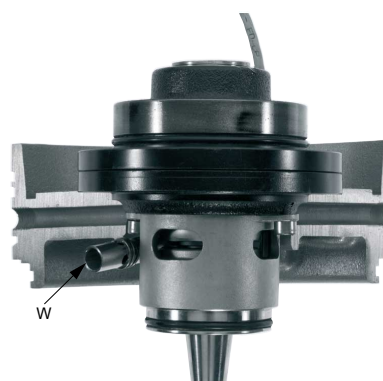

TM079199

Analog water-in-oil sensor

Pos.	Description
W	WIO sensor

As standard, the pump has thermal switches in the stator windings.

Customised analog sensor options

- Pt1000 sensor in motor windings for stator temperature measurements
- The WIO sensor fitted in the oil chamber of the pump monitors if water enters the pump from the liquid side. The sensor measures the water content (0 to 20 %) in the oil and converts the value into an analog current signal which is sent to the IO 113 sensor module. It also sends a signal if the water content is outside the normal range (warning), or if there is air in the oil chamber (alarm). The sensor is fitted in a stainless-steel tube for mechanical protection. See fig. [Analog water-in-oil sensor](#).
- The moisture switch fitted in the motor chamber monitors whether water enters the pump. If moisture is detected in the motor chamber, the moisture switch trips and sends a signal to the IO 113 sensor module.

Level controllers

Grundfos offers dedicated pump controllers for monitoring liquid levels in the wastewater collecting tanks to ensure correct operation and protection of the pumps.

The following pump controllers are available:

- Grundfos Dedicated Controls (DC)
- Grundfos LC controllers.

Grundfos DC Controllers



TM084174

Grundfos Dedicated Controls control cabinet

Grundfos Dedicated Controls (DC) is a control system designed for installation in municipal wastewater transportation, commercial buildings or network pumping stations with up to six wastewater pumps and an optional mixer or a flush valve.

Advanced control and data communication are also possible with the Grundfos DC system. The control cabinets are delivered with a built-in main switch and thermal-magnetic circuit breaker.

Features and benefits:

- Advanced Flow Calculation
- automatic energy optimization
- easy installation and configuration
- configuration wizard
- electrical overview
- advanced data communication
- advanced alarm and warning priority
- supports several languages
- daily emptying

- mixer control or flush valve
- user-defined functions
- anti-blocking
- start level variation
- advanced pump alternation with pump groups
- SMS scheduling
- communication to SCADA, BMS, GRM or cell phone.

Dedicated Controls is ordered either with or without a built-in communication interface module (CIM).

The communication module enables the possibility for fieldbus protocol (PROFIBUS DP, Modbus RTU and PROFINET IO/Modbus TCP) and the communication line.

For further information about Grundfos Dedicated Controls, see Grundfos Product Center:

- Grundfos Dedicated Controls, brochure <http://net.grundfos.com/qr/i/96925597>
- Grundfos iSolutions, brochure (L-IND-SL-05) <http://net.grundfos.com/qr/i/99249771>
- Grundfos Controls Guide, product guide <http://net.grundfos.com/qr/i/97954965>
- Grundfos Dedicated Controls, data booklet <http://net.grundfos.com/qr/i/98672840>.

Additional features, CUE or VFD

Grundfos variable frequency drive CUE or a general variable frequency drive (VFD) offers better pump protection and a more steady flow through the pipe system.

In addition, Grundfos CUE or variable frequency drive VFD offers the following features and benefits:

- anti-blocking
- automatic energy optimization
- specific-energy test
- output frequency
- monitoring of:
 - voltage*
 - current*
 - phase sequence*
 - power*
 - energy*
 - torque*
- reverse start**
- run flushing
- stop flushing
- PID control.

*These functions are only available with a Grundfos CUE.

** Reversing at full speed is not recommended. When reduced reverse operation settings are set, make sure constant torque is enabled in VFD (Grundfos CUE, Siemens Simatic, ABB, Schneider Electric etc.) to have maximum torque available when reversing.

Grundfos LC controllers

The LC 231 pump controller is designed for level control, monitoring and protection of Grundfos pumping stations featuring one or two pumps, starting direct-on-line. The LC 231 controller is built into a polymer cabinet.

The LC 241 is a modular pump controller that has a metal or polymer cabinet and can be customised.

The LC 231 and 241 controllers are designed for level control, monitoring and protection of Grundfos pumping stations featuring one or two pumps, starting direct-on-line with 0-23 A, star-delta with 0-59 A or soft starter with 0-72 A.



TM074000

LC 231 and LC 241 controller units

Operating mode

SE1 and SEV pumps are suitable for:

- dry installation without separate motor cooling
- submerged installation.

S1, continuous operation

In this operating mode, the pump can operate continuously when the pump housing is completely submerged.

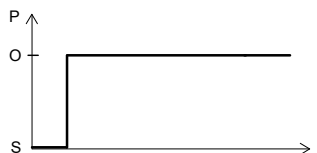

TM044528

S1 operation

Pos.	Description
O	Operation
S	Stop

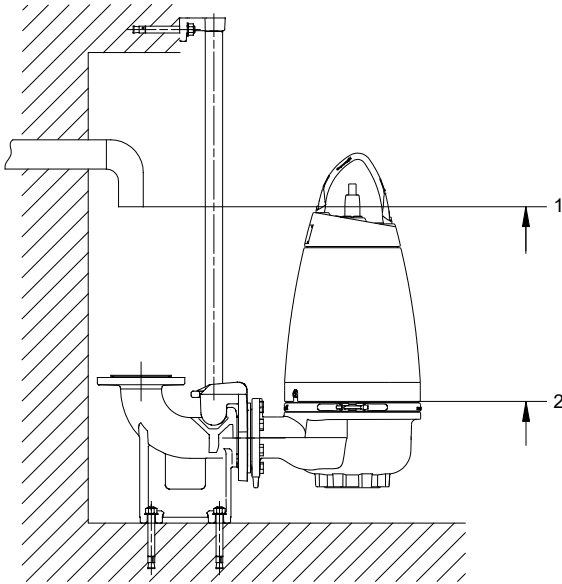

TMO65988

Start and stop levels

Pos.	Description
1	Max.
2	Min.

Pumped liquids

Pump type	Material variant	Installation	Material	pH value
SE1/S EV	Standard	Dry and submerged	Cast-iron pump housing and motor top according to EN-GJL-250.	6.5-14 ¹⁾
SEV	Q	Dry and submerged	Stainless steel impeller according to EN 1.4408. Cast-iron pump housing and motor top according to EN-GJL-250.	6-14 ¹⁾
SEV	R	Dry and submerged	Complete pump in stainless steel according to EN 1.4408/1.4301.	1-14
SEV	D	Dry and submerged	Stainless steel pump according to EN 1.4517/1.4539.	0-14

¹⁾ For fluctuating pH values, the range is 4 to 14 pH.

Liquid temperature

0-40 °C.

When pumping liquids with a density and a kinematic viscosity higher than that of water, use motors with correspondingly higher outputs.

For short periods of maximum 1 hour, a temperature of up to 60 °C is permissible. This only applies to non-Ex versions.

Sound pressure level

The sound pressure level of the pump is lower than the limiting values stated in the EC Machinery Directive 2006/42/EC.

Motor range

Output power [kW (Hp)]	Number of poles
1.1 (1.5 Hp)	4
1.3 (1.8 Hp)	4
1.5 (2 Hp)	4
2.2 (3 Hp)	2/4
3 (4 Hp)	2/4
4 (5.5 Hp)	2/4
5.5 (7.5 Hp)	4
6 (8 Hp)	2
7.5 (10 Hp)	2/4
9.2 (12.5 Hp)	2
11 (15 Hp)	2

Approvals

SE1 and SEV pump motors have been approved by FM Approvals. The explosion-proof pump motors have FM23US0056 and FM23CA0041X certificates.

Note

The letter X in the certificate number indicates that the equipment is subject to specific conditions for safe use. The conditions are described in the certificate and the installation and operating instructions.

Approval standards

These pumps have been approved by FM Approvals according to ANSI/UL 60079-0, ANSI/UL 60079-1, ANSI/IEC 60529, CSA C22.2 No. 60079-0, CSA C22.2 No. 60079-1, C22.2 No. 60529.

Explanation to FM approval

The SE1 and SEV pumps have the following explosion-protection classifications:

US: Class I, Zone 1, AEx db IIB T4/T3⁴⁾ Gb

Canada: Ex db IIB T4/T3⁴⁾ Gb.

Standards	Code	Description
ANSI/UL 60079-0 ANSI/UL 60079-1 ANSI/IEC 60529	Class I	Flammable vapors and gases may be present
	Zone 1	Flammable material present intermittently or continuously
	AEx	Marking of explosion protection
	db	Flameproof enclosure
	IIB	Classification of gasses, gas group B includes gas group A
	T4/T3 ⁴⁾	Maximum surface temperature is 275 °F (135 °C) and 392 °F (200 °C)
	Gb	Suitable for use in explosive gas atmospheres in Zone 1 and Zone 2
Standards	Code	Description
CSA C22.2 No. 60079-0 CSA C22.2 No. 60079-1 C22.2 No. 60529	Ex	Marking of explosion protection
	db	Flameproof enclosure
	IIB	Classification of gasses, gas group B includes gas group A
	T4/T3 ⁴⁾	Maximum surface temperature is 275 °F (135 °C) and 392 °F (200 °C)
	Gb	Suitable for use in explosive gas atmospheres in Zone 1 and Zone 2

⁴⁾ Motor T-code is T3 when used with a frequency converter.

Controllers

The pumps must be connected to a control box with a motor protection relay with IEC trip class 10 or 15.

Note: Pumps for hazardous locations must be connected to a control box with a motor protection relay with IEC trip class 10.

Frequency converter, CUE/VFD

All pump types are designed for speed-controlled operation to keep the energy consumption at a minimum.

To avoid the risk of sedimentation in the pipes, operate the speed-controlled pump within a speed range of 30 % to 100 % and at a flow rate above 1 m/s.

For more information, see the installation and operating instructions of the relevant frequency converter on www.grundfos.com (Grundfos Product Center).

Additional features

- anti-blocking
- automatic energy optimization
- specific-energy test
- output frequency
- monitoring of:
 - voltage⁵⁾
 - current⁵⁾
 - phase sequence⁵⁾
 - power⁵⁾
 - energy⁵⁾
 - torque.⁵⁾
- reverse start
- run flushing
- stop flushing
- PID control.

⁵⁾ These functions are only available with a Grundfos CUE.

DC and LC control units

Grundfos offers dedicated pump controllers for monitoring liquid levels in the wastewater collecting tanks to ensure correct operation and the protection of the pumps.

The following Grundfos pump controllers are available:

- Grundfos Dedicated Controls (DC)
- Grundfos LC controllers.

Grundfos DC Controllers



TM084174

Grundfos Dedicated Controls control cabinet

Grundfos Dedicated Controls (DC) is a control system designed for installation in municipal wastewater transport, commercial buildings or network pumping stations with up to six wastewater pumps and an optional mixer or a flush valve.

Advanced control and data communication are possible with the Grundfos Dedicated Controls system. The control cabinets are delivered with a built-in main switch and thermal-magnetic circuit breaker.

Features and benefits:

- advanced Flow Calculation
- automatic energy optimization
- easy installation and configuration
- configuration wizard
- electrical overview
- advanced data communication
- advanced alarm and warning priority
- several languages
- daily emptying
- mixer control or flush valve
- user-defined functions
- anti-blocking
- start level variation
- advanced pump alternation with pump groups
- SMS scheduling
- communication to SCADA, BMS, GRM or cell phone.

Dedicated Controls is ordered either with or without a built-in communication interface module (CIM).

The communication module enables the possibility for fieldbus protocol (e.g. PROFIBUS DP, Modbus RTU and PROFINET IO/Modbus TCP) and the communication line.

For further information about Grundfos Dedicated Controls, see www.grundfos.com (Grundfos online selection tool):

- Grundfos Dedicated Controls, brochure <http://net.grundfos.com/qr/i/96925597>
- Grundfos iSolutions, brochure <http://net.grundfos.com/qr/i/99249771>
- Grundfos Controls Guide, product guide <http://net.grundfos.com/qr/i/96932422>
- Grundfos Dedicated Controls, data booklet <http://net.grundfos.com/qr/i/96932407>.

Additional features, CUE or VFD

The Grundfos variable frequency drive (CUE) or a general variable frequency drive (VFD) offers better pump protection and a steadier flow through the pipe system.

Features and benefits:

- anti-blocking
- automatic energy optimization
- specific-energy test
- output frequency
- monitoring of:
 - voltage⁶⁾
 - current
 - phase sequence⁶⁾
 - power⁶⁾
 - energy⁶⁾
 - torque⁶⁾
- reverse start⁷⁾
- run flushing
- stop flushing
- PID control.

⁶⁾ These functions are only available with a Grundfos CUE.

⁷⁾ Reversing at full speed is not recommended. When reduced reverse operation settings are applied, make sure that constant torque is enabled in VFD (Grundfos CUE, Siemens Simatic, ABB, Schneider Electric) to have maximum torque available when reversing.

Grundfos LC controllers

The LC 231 pump controller is designed for level control, monitoring and protection of Grundfos pumping stations featuring one or two pumps, starting direct-on-line. The LC 231 controller is built into a polymer cabinet.

The LC 241 is a modular pump controller that has a metal or polymer cabinet and can be customised.

The LC 231 and 241 controllers are designed for level control, monitoring and protection of Grundfos pumping stations featuring one or two pumps, starting direct-on-line with 0-23 A, star-delta with 0-59 A or soft starter with 0-72 A.



LC 231 and LC 241 controller units

TM074000

IO 113 sensor module



IO 113 sensor module

GR-1014619

The IO 113 module is a protection module for Grundfos wastewater pumps.

The module has inputs for digital and analog pump sensors and can stop the pump if a sensor detects a pump fault. It can be connected to the Grundfos Dedicated Controls system which provides advanced monitoring functions:

- stator temperature
- stator insulation resistance
- water-in-oil chamber
- moisture in motor.

Wiring diagrams

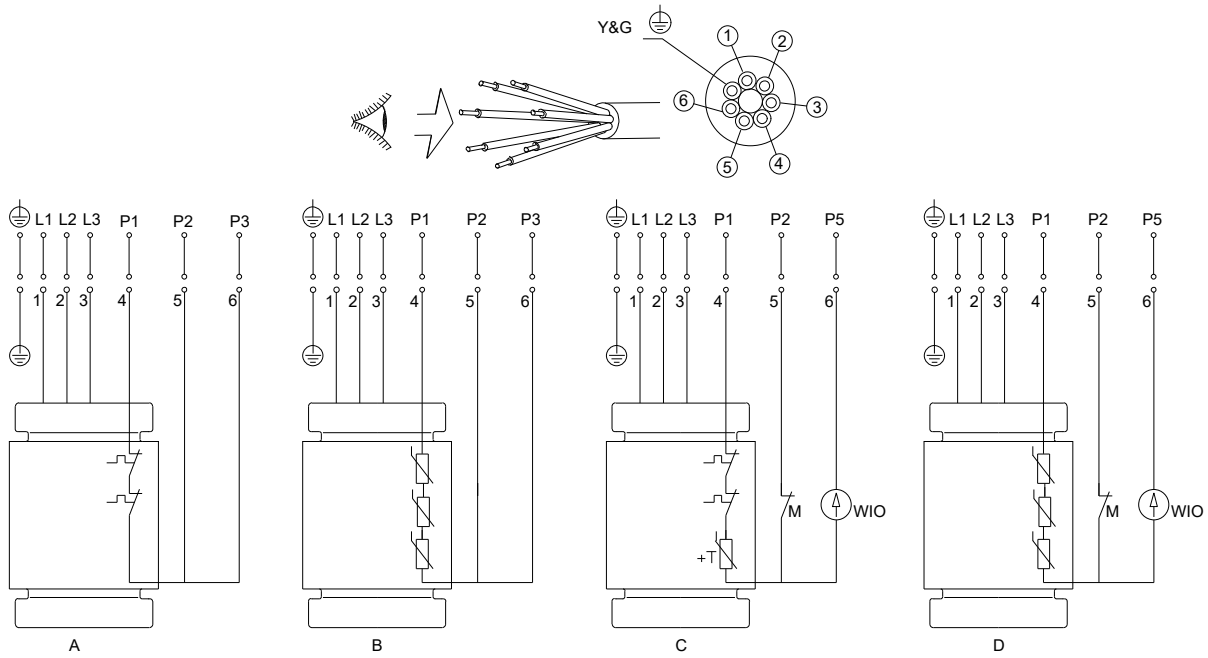

TM046884

Wiring diagram, 7-core cable, DOL



EMC cables for dual voltage must be selected for the specific voltage code. Example:

- 61R 3 x 230 V EMC cable Delta connection in plug
- 61R 3 x 460 V EMC cable Star connection in plug

Pos.	Description
Y&G	Yellow and green
A	Standard version with thermal switches
B	Standard version with PTC thermistors*
C	Sensor version with thermal switches, Pt1000, moisture switch and WIO sensor
D	Sensor version with PTC thermistors, moisture switch and WIO sensor*

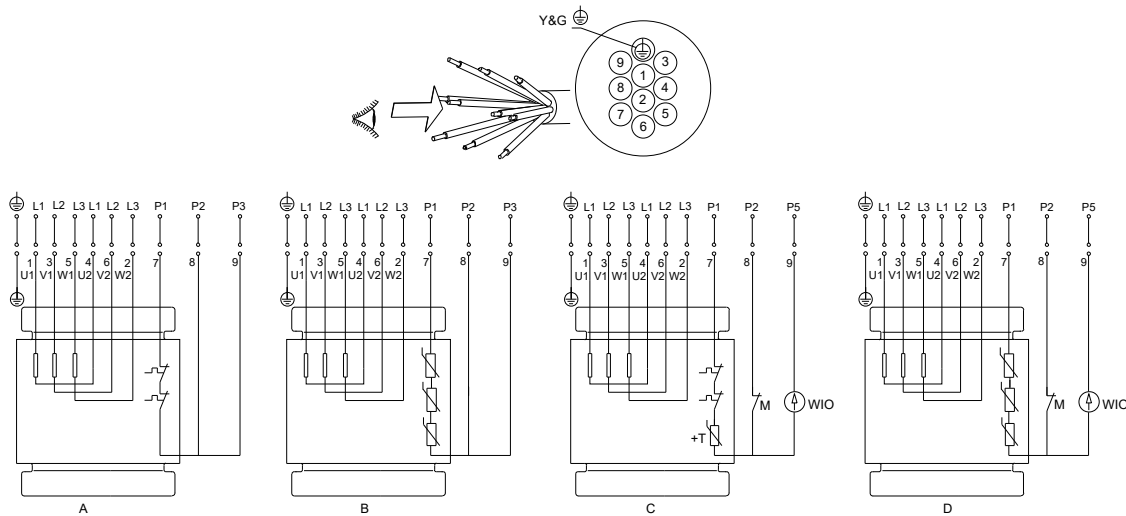

TM046885

Wiring diagram, 10-core cable, star/delta (Y/D)

Pos.	Description
Y&G	Yellow and green
A	Standard version with thermal switches
B	Standard version with PTC thermistors*
C	Sensor version with thermal switches, Pt1000, moisture switch and WIO sensor
D	Sensor version with PTC thermistors, moisture switch and WIO sensor*

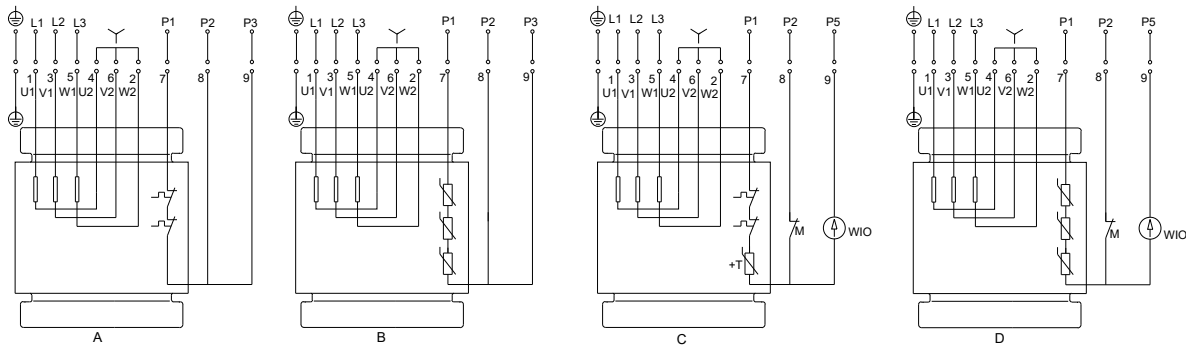
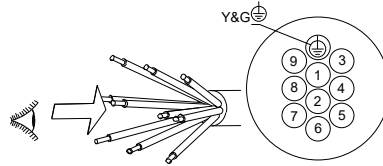

TM046886

Wiring diagram, 10-core cable, star-connected (Y)

Pos.	Description
Y&G	Yellow and green
A	Standard version with thermal switches
B	Standard version with PTC thermistors*
C	Sensor version with thermal switch, Pt1000, moisture switch and WIO sensor
D	Sensor version with PTC thermistors, moisture switch and WIO sensor*

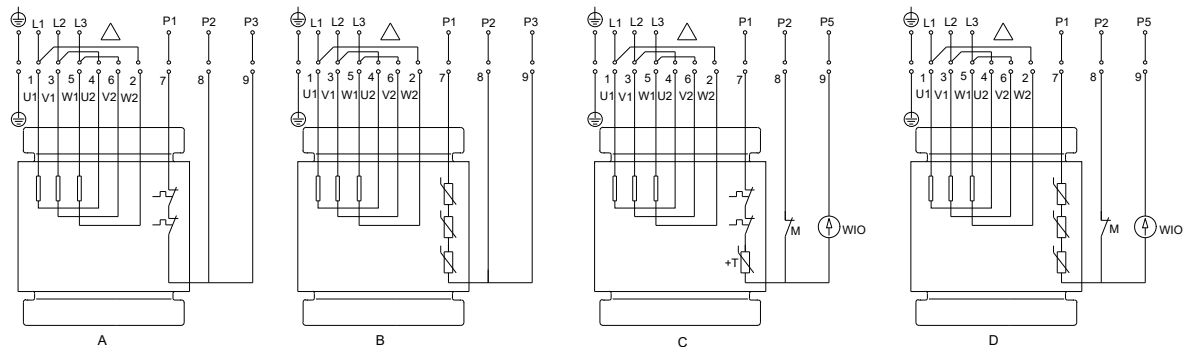
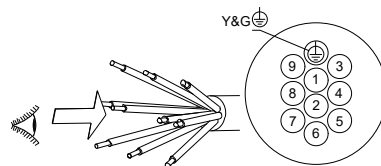

TM046887

Wiring diagram, 10-core cable, delta-connected (D)

Pos.	Description
Y&G	Yellow and green
A	Standard version with thermal switches
B	Standard version with PTC thermistors*
C	Sensor version with thermal switch, Pt1000, moisture switch and WIO sensor
D	Sensor version with PTC thermistors, moisture switch and WIO sensor*

9. Performance curves and technical data

How to read the performance curves

Example curve:

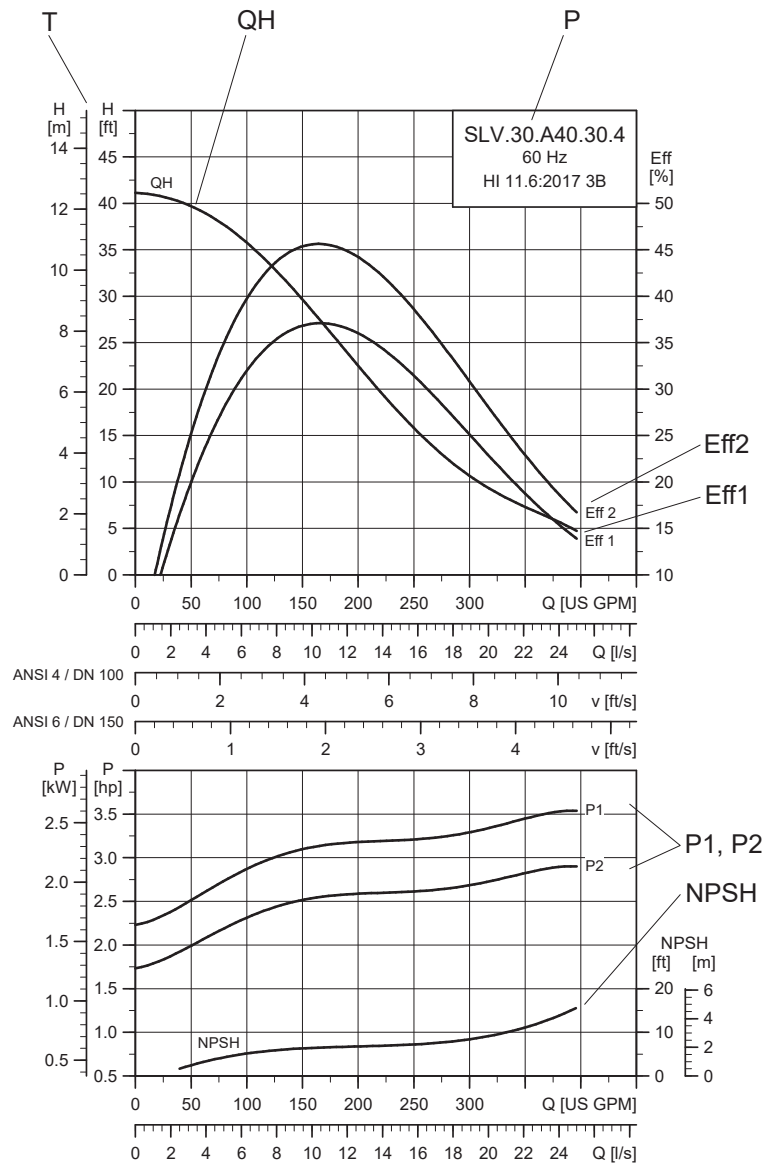

TM1040009

Pos.	Description
T	Total pump head $H = H_{total}$
QH	QH curve
P	Pump type
Eta 2	Eta 2 is the hydraulic efficiency (pump).
Eta 1	Eta 1 is the total efficiency (pump + motor).
P1, P2	Power curves indicating motor input power [P ₁] and motor output power [P ₂] of the pump
NPSH	NPSH curves. When sizing the pumps, add a safety margin of at least 0.5 m.

Note: The pumps are tested according to AISI HI:2022, grade 3B tolerance. Testing equipment and measuring instruments are designed and calibrated according to the standards mentioned. The pumps are approved according to tolerances for entire curves, specified in grade 3B.

Curve conditions

The guidelines below apply to the curves shown in the performance charts in Performance curves and technical datacolour .

- Tolerances according to HI 11.6 - 2022 acceptance level 3B.
- The curves show pump performance with different impeller diameters at the rated speed.
- The bold part of the curves show the recommended operating range.
- The curves apply to the pumping of airless water at a temperature of 68 °F (20 °C) and a kinematic viscosity of 1 cSt (1.076 (ft²/s) x 10⁻⁵).
- **Eff:** The lines show values of the hydraulic efficiency, i.e. Eff1 is the total efficiency (pump + motor) and Eff2 is the hydraulic efficiency (pump).
- **NPSH:** The curves show average values measured under the same conditions as the performance curves. When dimensioning the pump, add a safety margin of at least 1.6 ft (0.5 m).
- In case of densities other than 133.5 ounces/gallon (1000 kg/m³), the outlet pressure is proportional to the density.
- When pumping liquids with a density higher than 133.5 ounces/gallon (1000 kg/m³), motors with correspondingly higher outputs must be used.

Calculation of total head

The total pump head consists of the height difference between the measuring points + the differential head + the dynamic head.

$$H_{\text{total}} = H_{\text{geo}} + H_{\text{stat}} + H_{\text{dyn}}$$

H_{geo} :	Height difference between measuring points.
H_{stat} :	Differential head between the inlet and the outlet side of the pump.
H_{dyn} :	Calculated values based on the velocity of the pumped liquid on the inlet and the outlet side of the pump.

Performance tests

All pumps are factory tested to a Grundfos testing standard that is similar to the hydraulic Institute 11.6:2022 grade 3B. These Grundfos standard curves are provided with each pump. For tests according to ANSI/HI 11.6:2022 grade 3B, see .

The testing equipment and measuring instruments are designed and calibrated in accordance with the mentioned standards.

For customized duty point or other grades with 5 point test certificate, please contact Grundfos in order to agree on terms before ordering.

Performance curves for pumps with stainless steel impellers

Performance curves for pumps with stainless steel impellers are slightly different to that of the equivalent cast iron impeller. All the performance curves displayed in this section, are for pumps with cast iron impellers. Please see Grundfos Product Center for accurate performance curves for all pumps with stainless steel impellers.

Certificates

Certificates have to be confirmed for every order and are available on request. See .

Witness test

It is possible for the customer to witness the testing procedure according to Hydraulic Institute 11.6 - 2022.

The witness test is not a certificate and will not result in a written statement from Grundfos. The witness test only guarantees that everything is carried out as prescribed in the testing procedure.

If the customer wants to witness the pump performance test, such request must be stated on the order.

SE1.20.A25.30.2

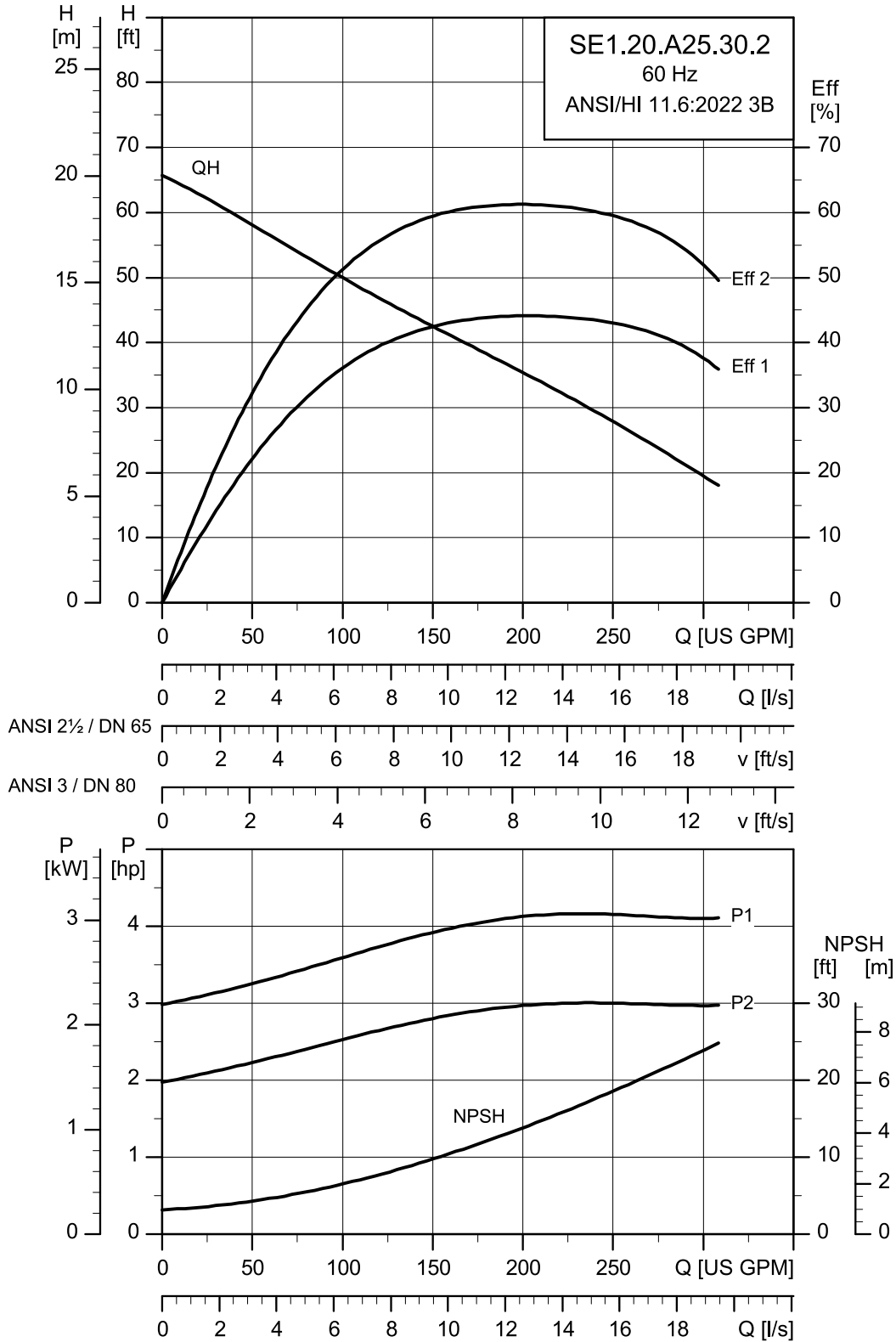

TM086454

Motor data

Pump type	Voltage [V]	P1 [Hp]	P2 [Hp]	No. of poles	RPM	Starting method	I _N [A]	I _{start} [A]	η _{motor} [%]			Cos φ		
									1/2	3/4	1/1	1/2	3/4	1/1
SE1.20.A25.30.A.EX.2.60R.B	230	4.072	3	2	3.472	Direct-on-line (DOL)	8.7	50	80.5	82.6	82.3	0.83	0.88	0.9
SE1.20.A25.30.A.EX.2.60H.B	460	4.072	3	2	3.510	Direct-on-line (DOL)	5	34.5	78.4	82.4	83.7	0.7	0.8	0.85

Pump data

Pump type	Impeller diameter [mm]	Moment of inertia (impeller) [kgm ²]	Outlet flange pressure (according to EN 1092-2)	Max. installation depth	Moment of inertia (motor) [kgm ²]	Breakdown torque M _{max} [Nm]
SE1.20.A25.30.A.EX.2.60R.B	108.5	0.00380	PN 10	12	0.00190	14.6
SE1.20.A25.30.A.EX.2.60H.B	108.5	0.00380	PN 10	12	0.00190	21.8

SE1.20.A25.40.2

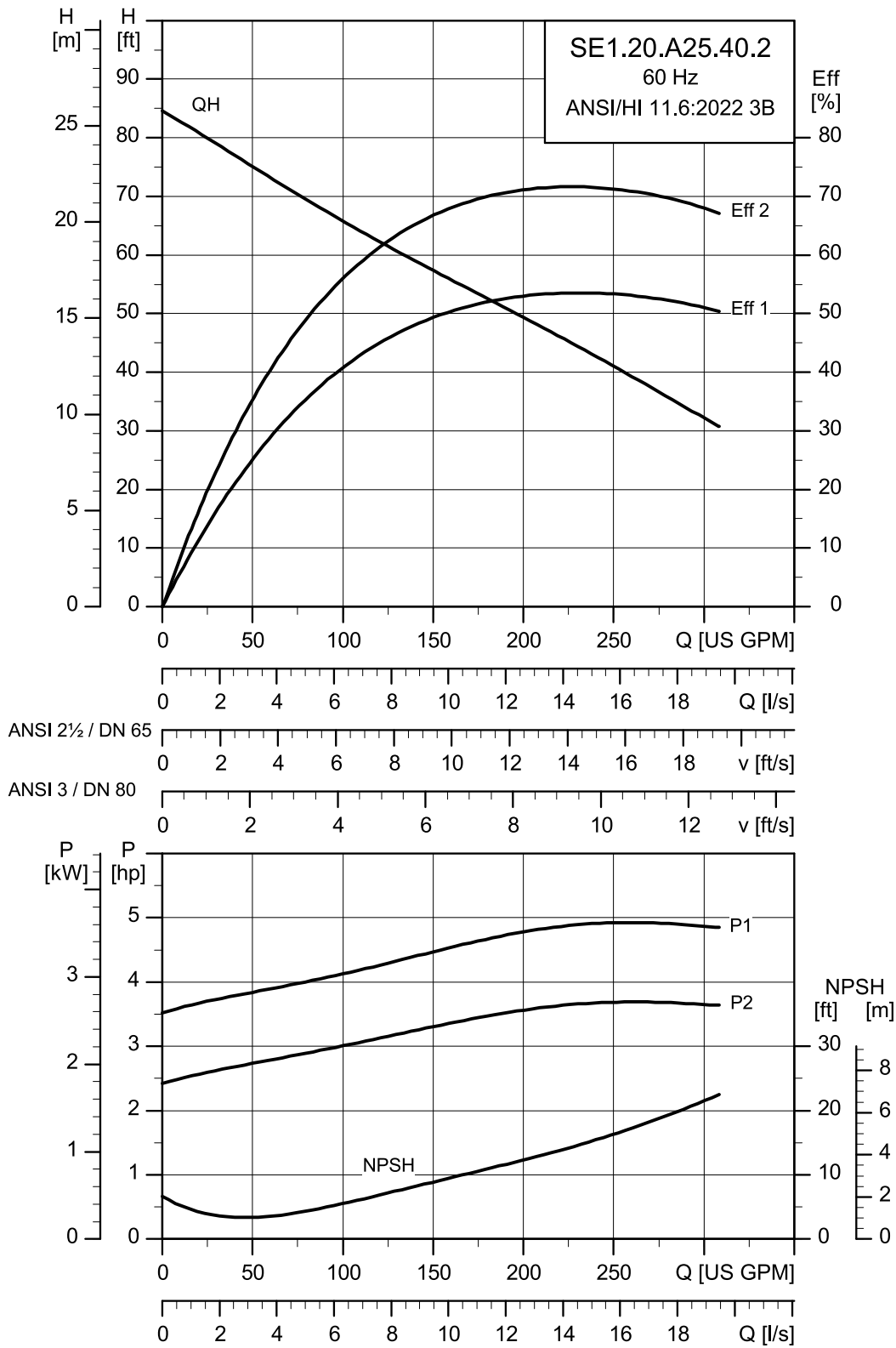

TM086455

Motor data

Pump type	Voltage [V]	P1 [Hp]	P2 [Hp]	No. of poles	RPM	Starting method	I _N [A]	I _{start} [A]	η _{motor} [%]			Cos φ		
									1/2	3/4	1/1	1/2	3/4	1/1
SE1.20.A25.40.A.EX.2.60R.B	230	5.362	4	2	3.463	Direct-on-line (DOL)	10.14	66	81.2	82.9	82.1	0.85	0.89	0.91
SE1.20.A25.40.A.EX.2.60H.B	460	5.362	4	2	3.506	Direct-on-line (DOL)	5.07	46	79.9	83.4	84.3	0.77	0.85	0.88

Pump data

Pump type	Impeller diameter [mm]	Moment of inertia (impeller) [kgm ²]	Outlet flange pressure (according to EN 1092-2)	Max. installation depth	Moment of inertia (motor) [kgm ²]	Breakdown torque M _{max} [Nm]
SE1.20.A25.40.A.EX.2.60R.B	119	0.00482	PN 10	12	0.00260	16.4
SE1.20.A25.40.A.EX.2.60H.B	119	0.00482	PN 10	12	0.00260	23.4

SE1.20.A25.55.2

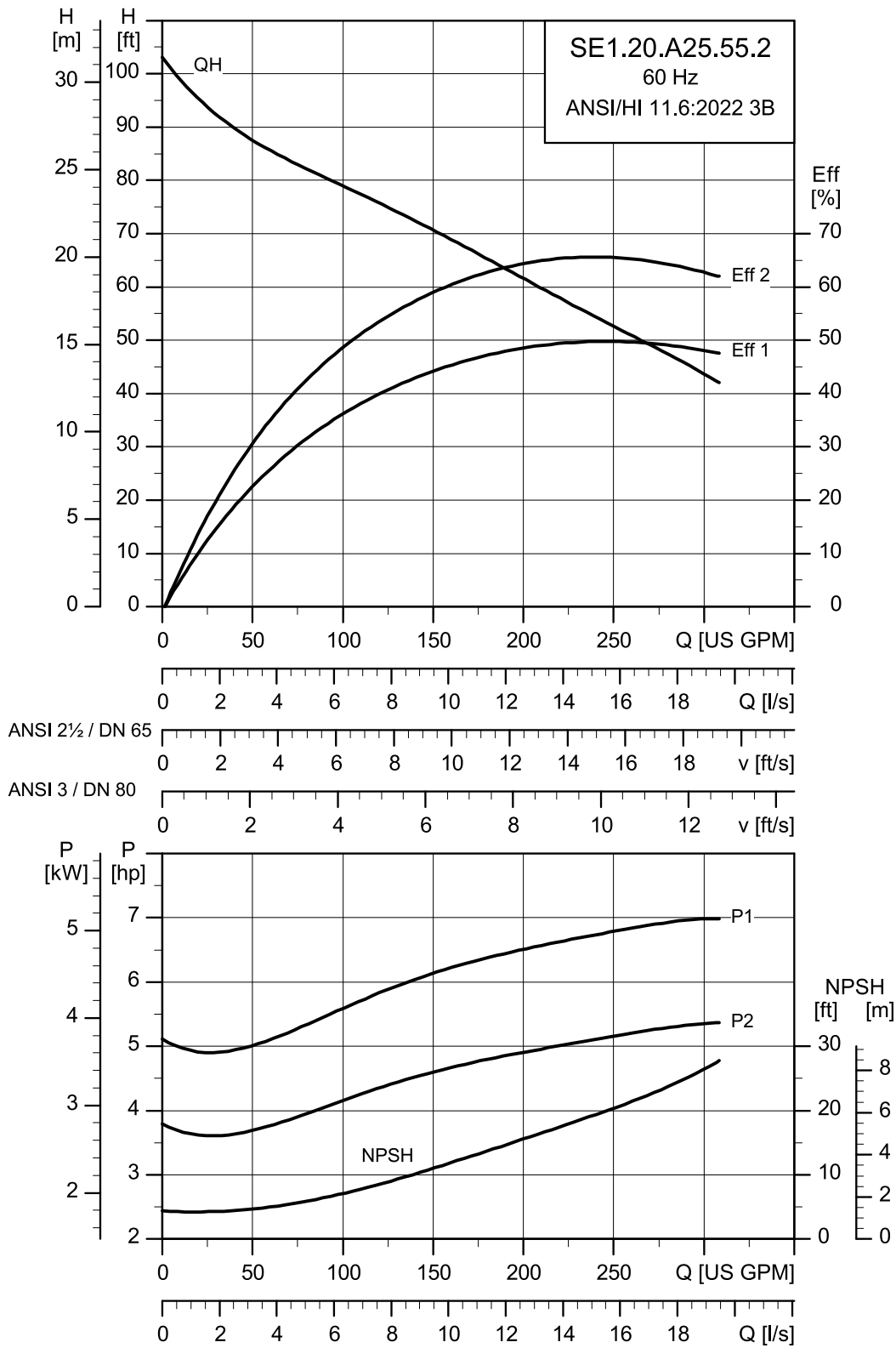

TM086456

Motor data

Pump type	Voltage [V]	P1 [Hp]	P2 [Hp]	No. of poles	RPM	Starting method	I _N [A]	I _{start} [A]	η _{motor} [%]			Cos φ		
									1/2	3/4	1/1	1/2	3/4	1/1
SE1.20.A25.55.A.EX.2.61R.B	230	6.985	5.5	2	3.485	Star-delta (YD)	13.05	93.5	84.5	86	85.6	0.82	0.88	0.9
	460								6.7	63.5	83.5	86.3	87.1	0.71

Pump data

Pump type	Impeller diameter [mm]	Moment of inertia (impeller) [kgm ²]	Outlet flange pressure (according to EN 1092-2)	Max. installation depth	Moment of inertia (motor) [kgm ²]	Breakdown torque M _{max} [Nm]
SE1.20.A25.55.A.EX.2.61R.B	127	0.00755	PN 10	12	0.00540	31 45.5

SE1.20.A30.30.2

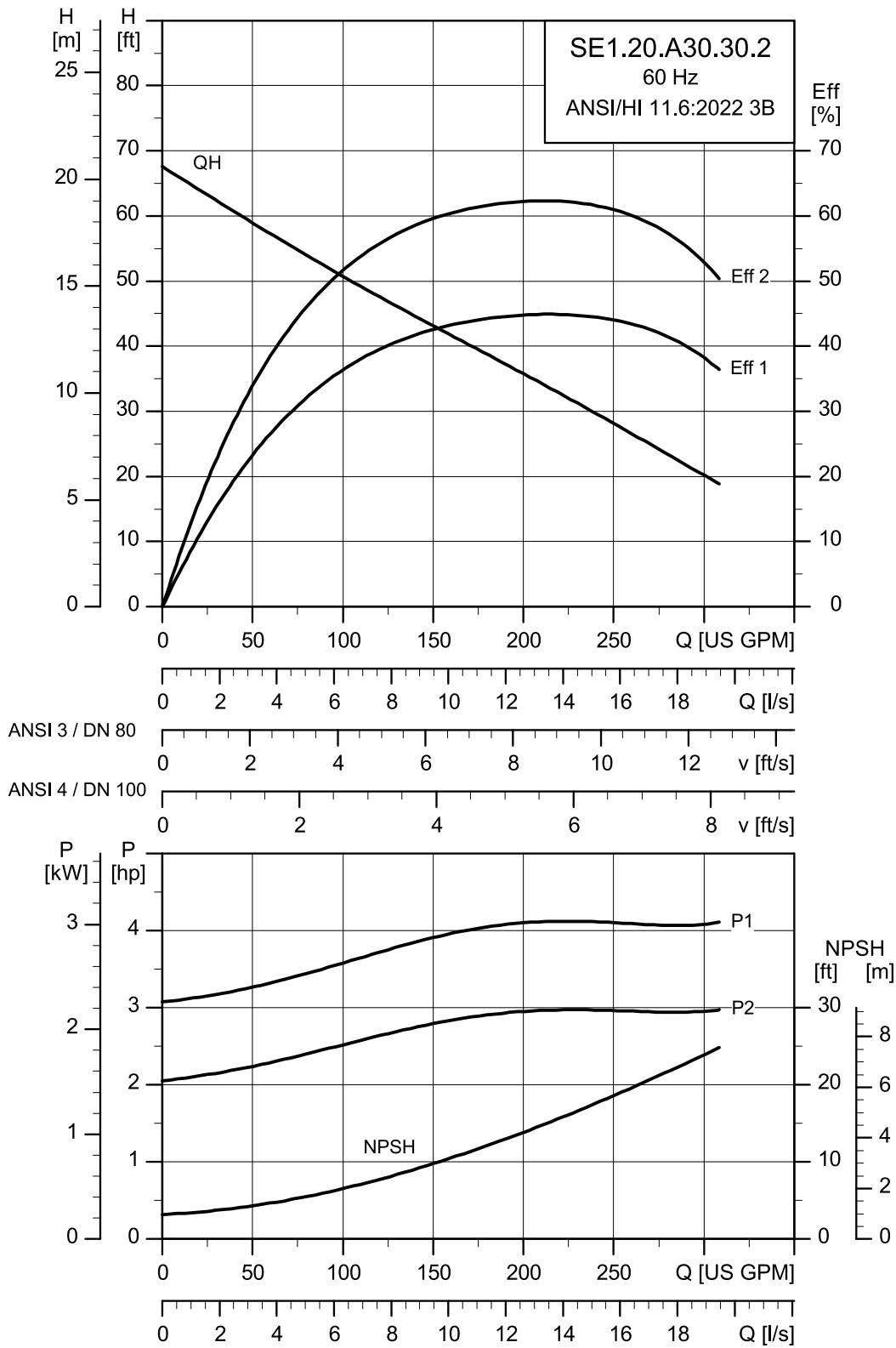

TM086457

Motor data

Pump type	Voltage [V]	P1 [Hp]	P2 [Hp]	No. of poles	RPM	Starting method	I _N [A]	I _{start} [A]	η _{motor} [%]			Cos φ		
									1/2	3/4	1/1	1/2	3/4	1/1
SE1.20.A30.30.A.EX.2.60R.B	230	4.076	3	2	3.472	Direct-on-line (DOL)	8.7	50	80.5	82.6	82.3	0.83	0.88	0.9
SE1.20.A30.30.A.EX.2.60H.B	460	4.076	3	2	3.510	Direct-on-line (DOL)	5	34.5	78.4	82.4	83.7	0.7	0.8	0.85

Pump data

Pump type	Impeller diameter [mm]	Moment of inertia (impeller) [kgm ²]	Outlet flange pressure (according to EN 1092-2)	Max. installation depth	Moment of inertia (motor) [kgm ²]	Breakdown torque M _{max} [Nm]
SE1.20.A30.30.A.EX.2.60R.B	108.5	0.00380	PN 10	12	0.00190	14.6
SE1.20.A30.30.A.EX.2.60H.B	108.5	0.00380	PN 10	12	0.00190	21.8

SE1.20.A30.40.2

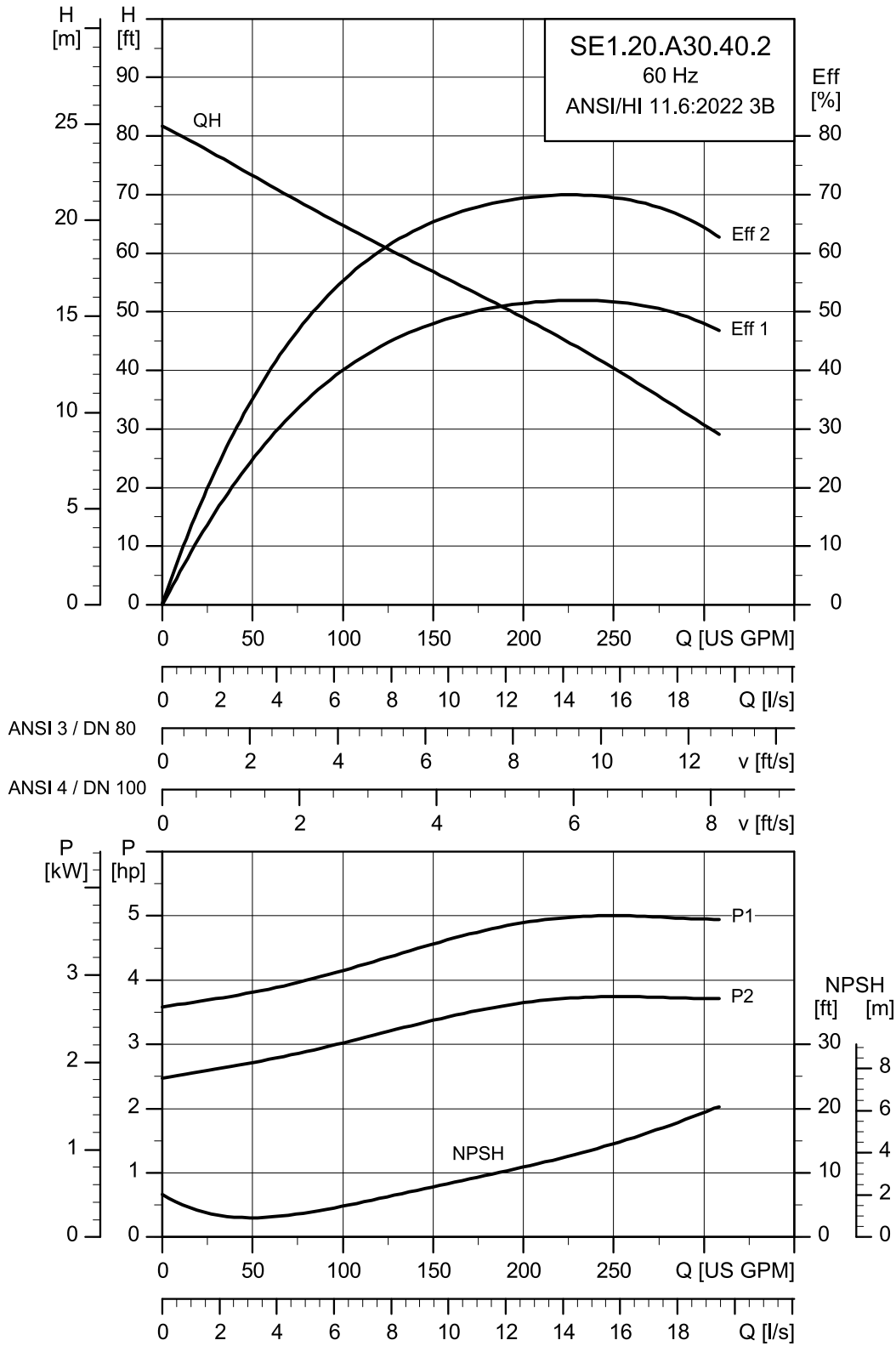

TM086458

Motor data

Pump type	Voltage [V]	P1 [Hp]	P2 [Hp]	No. of poles	RPM	Starting method	I _N [A]	I _{start} [A]	η _{motor} [%]			Cos φ		
									1/2	3/4	1/1	1/2	3/4	1/1
SE1.20.A30.40.A.EX.2.60R.B	230	5.363	4	2	3.463	Direct-on-line (DOL)	10.14	66	81.2	82.9	82.1	0.85	0.89	0.91
SE1.20.A30.40.A.EX.2.60H.B	460	5.363	4	2	3.506	Direct-on-line (DOL)	5.07	46	79.9	83.4	84.3	0.77	0.85	0.88

Pump data

Pump type	Impeller diameter [mm]	Moment of inertia (impeller) [kgm ²]	Outlet flange pressure (according to EN 1092-2)	Max. installation depth	Moment of inertia (motor) [kgm ²]	Breakdown torque M _{max} [Nm]
SE1.20.A30.40.A.EX.2.60R.B	119	0.00482	PN 10	12	0.00260	16.4
SE1.20.A30.40.A.EX.2.60H.B	119	0.00482	PN 10	12	0.00260	23.4

SE1.20.A30.55.2

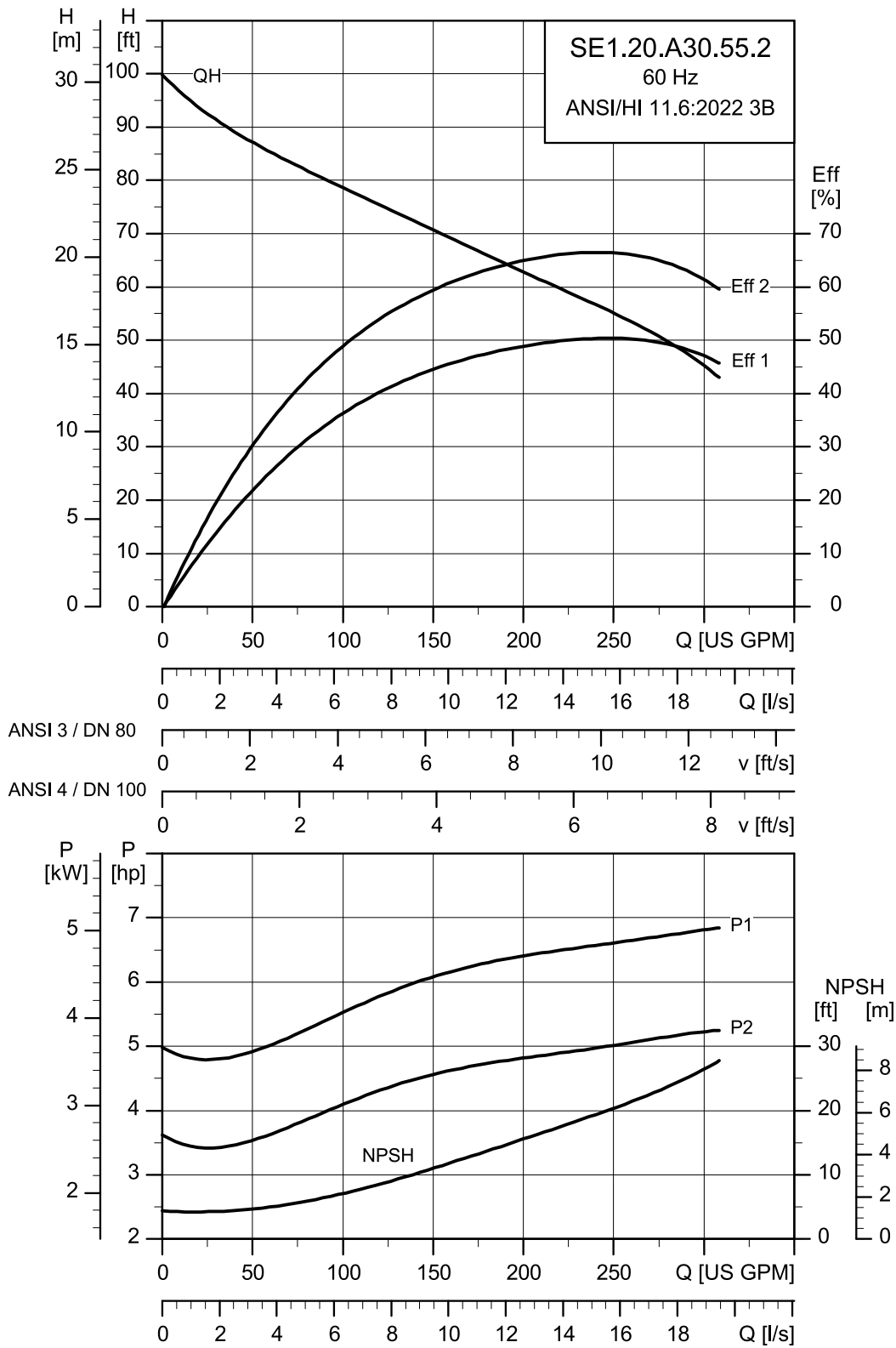

TM086459

Motor data

Pump type	Voltage [V]	P1 [Hp]	P2 [Hp]	No. of poles	RPM	Starting method	I _N [A]	I _{start} [A]	η _{motor} [%]			Cos φ		
									1/2	3/4	1/1	1/2	3/4	1/1
SE1.20.A30.55.A.EX.2.61R.B	230	6.987	5.5	2	3.485	Star-delta (YD)	13.05	93.5	84.5	86	85.6	0.82	0.88	0.9
	460								6.7	63.5	83.5	86.3	87.1	0.71

Pump data

Pump type	Impeller diameter [mm]	Moment of inertia (impeller) [kgm ²]	Outlet flange pressure (according to EN 1092-2)	Max. installation depth	Moment of inertia (motor) [kgm ²]	Breakdown torque M _{max} [Nm]
SE1.20.A30.55.A.EX.2.61R.B	127	0.00755	PN 10	12	0.00540	31 45.5

SE1.30.A30.20.4

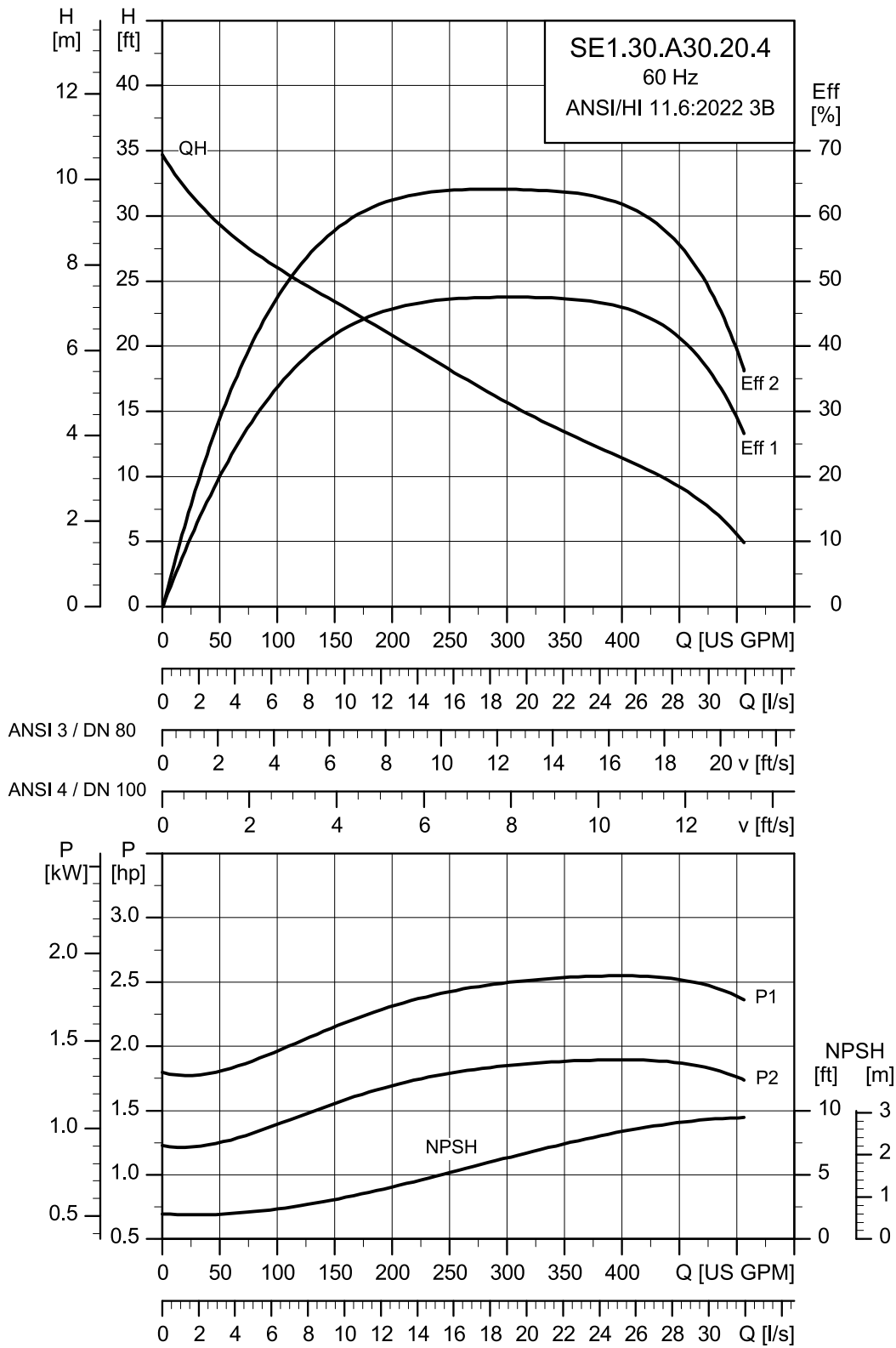

TM086461

Motor data

Pump type	Voltage [V]	P1 [Hp]	P2 [Hp]	No. of poles	RPM	Starting method	I _N [A]	I _{start} [A]	η _{motor} [%]			Cos φ		
									1/2	3/4	1/1	1/2	3/4	1/1
SE1.30.A30.20.A.EX.4.60R.B	230	2.704	2	4	1.703	Direct-on-line (DOL)	7.3	29.5	77.5	79	77.1	0.71	0.79	0.83
SE1.30.A30.20.A.EX.4.60H.B	460	2.704	2	4	1.739	Direct-on-line (DOL)	4.2	20.2	74.7	78.9	80	0.57	0.69	0.77

Pump data

Pump type	Impeller diameter [mm]	Moment of inertia (impeller) [kgm ²]	Outlet flange pressure (according to EN 1092-2)	Max. installation depth	Moment of inertia (motor) [kgm ²]	Breakdown torque M _{max} [Nm]
SE1.30.A30.20.A.EX.4.60R.B	152	0.01931	PN 10	12	0.00330	19.4
SE1.30.A30.20.A.EX.4.60H.B	152	0.01931	PN 10	12	0.00330	26.5

SE1.30.A30.30.4

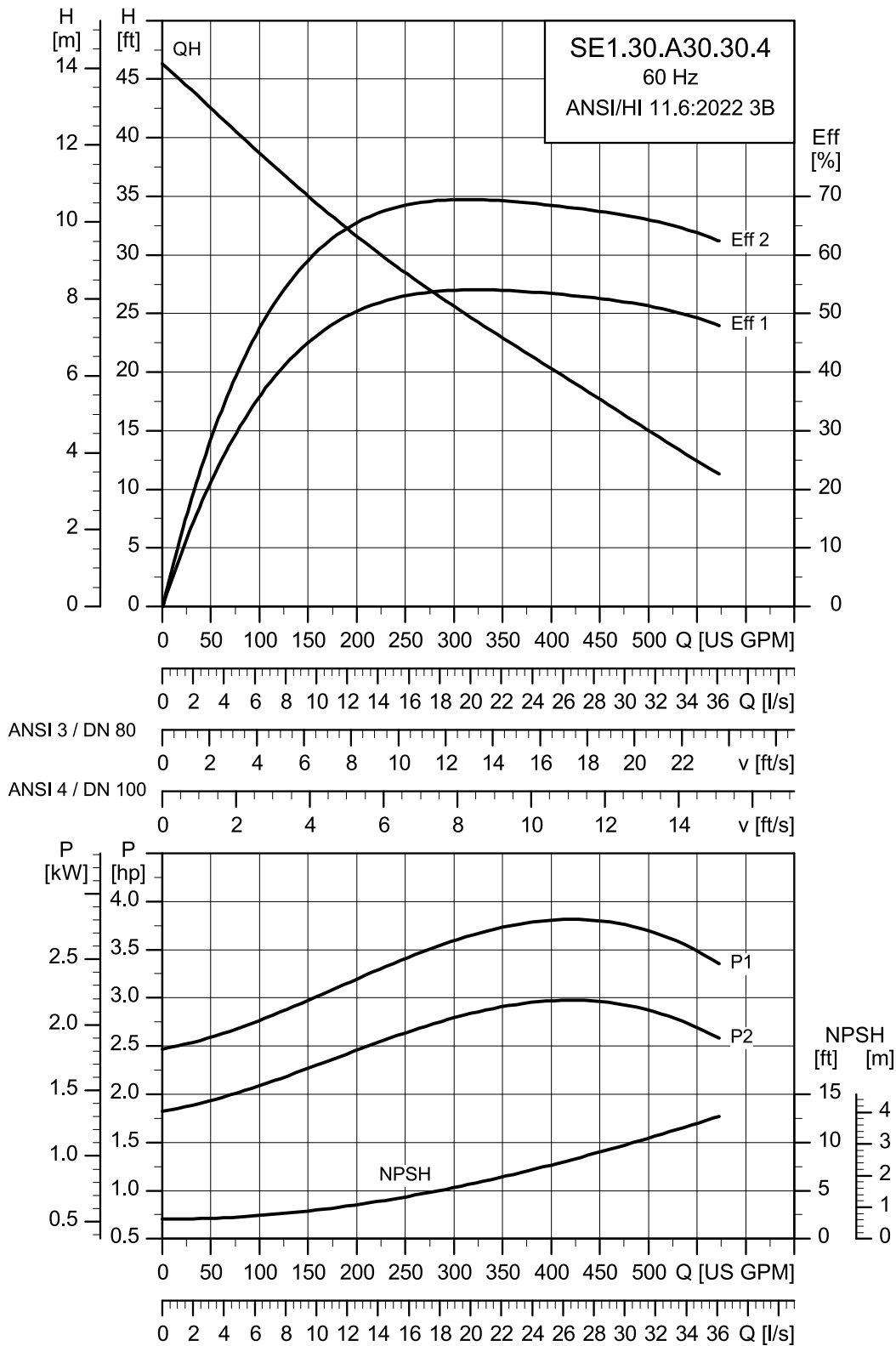

TM086462

Motor data

Pump type	Voltage [V]	P1 [Hp]	P2 [Hp]	No. of poles	RPM	Starting method	I _N [A]	I _{start} [A]	η _{motor} [%]			Cos φ		
									1/2	3/4	1/1	1/2	3/4	1/1
SE1.30.A30.30.A.EX.4.60R.B	230	3.78	3	4	1.717	Direct-on-line (DOL)	8.19	51.5	80.6	82.1	81	0.69	0.78	0.83
SE1.30.A30.30.A.EX.4.60H.B	460	3.78	3	4	1.743	Direct-on-line (DOL)	5.9	35.5	77.2	81.1	82.4	0.52	0.65	0.74

Pump data

Pump type	Impeller diameter [mm]	Moment of inertia (impeller) [kgm ²]	Outlet flange pressure (according to EN 1092-2)	Max. installation depth	Moment of inertia (motor) [kgm ²]	Breakdown torque M _{max} [Nm]
SE1.30.A30.30.A.EX.4.60R.B	172	0.03163	PN 10	12	0.00440	33.5
SE1.30.A30.30.A.EX.4.60H.B	172	0.03163	PN 10	12	0.00440	45.5

SE1.30.A30.40.4

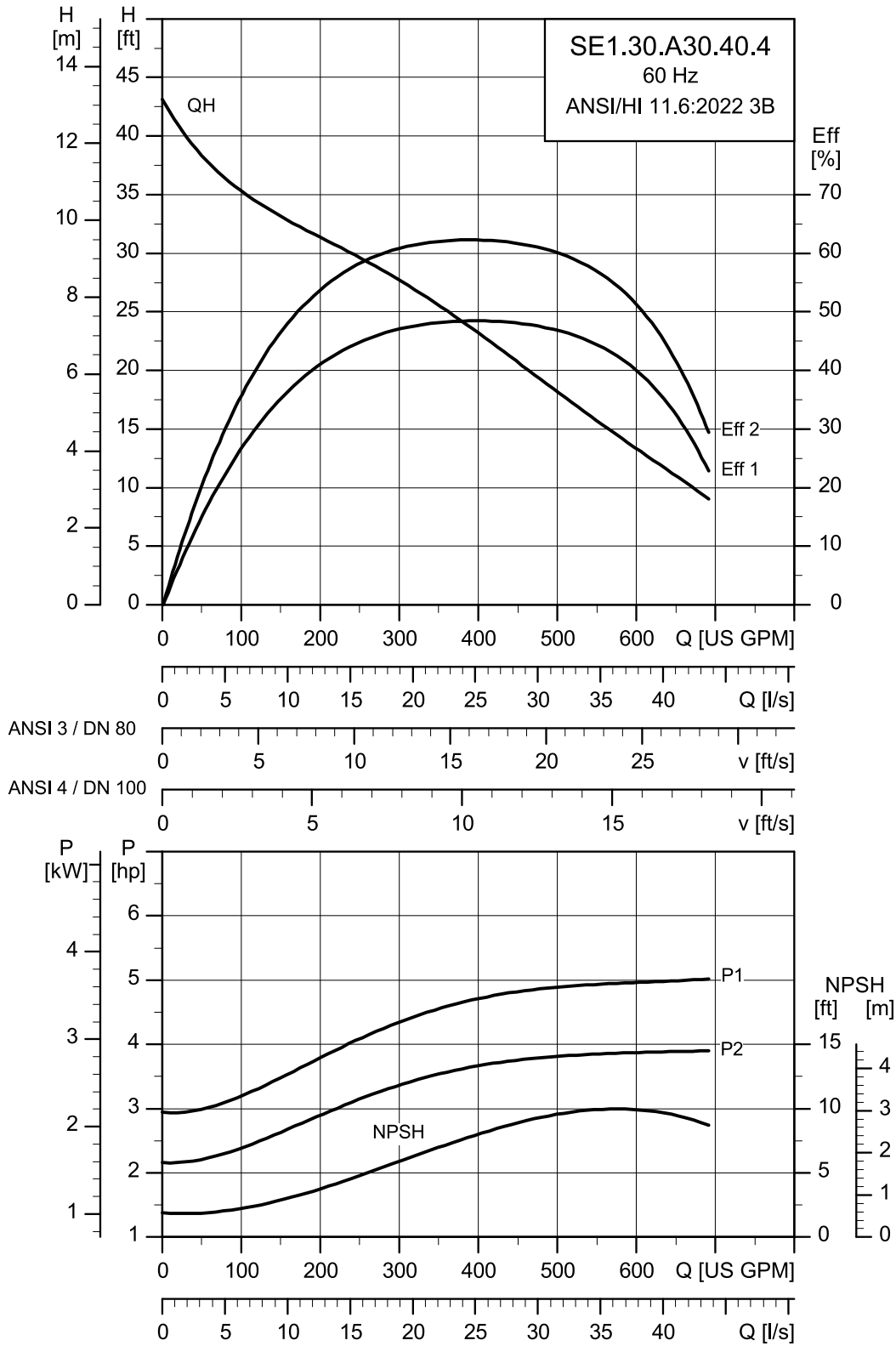

TM086463

Motor data

Pump type	Voltage [V]	P1 [Hp]	P2 [Hp]	No. of poles	RPM	Starting method	I _N [A]	I _{start} [A]	η _{motor} [%]			Cos φ		
									1/2	3/4	1/1	1/2	3/4	1/1
SE1.30.A30.40.A.EX.4.61R.B	230	5.154	4	4	1.739	Star-delta (YD)	10.59	68	84.7	85.6	84.8	0.69	0.79	0.83
	460								82.6	85.5	86.3	0.55	0.68	0.76

Pump data

Pump type	Impeller diameter [mm]	Moment of inertia (impeller) [kgm ²]	Outlet flange pressure (according to EN 1092-2)	Max. installation depth	Moment of inertia (motor) [kgm ²]	Breakdown torque M _{max} [Nm]
SE1.30.A30.40.A.EX.4.61R.B	171	0.03829	PN 10	12	0.01040	47.5
						64.5

SE1.30.A30.55.4

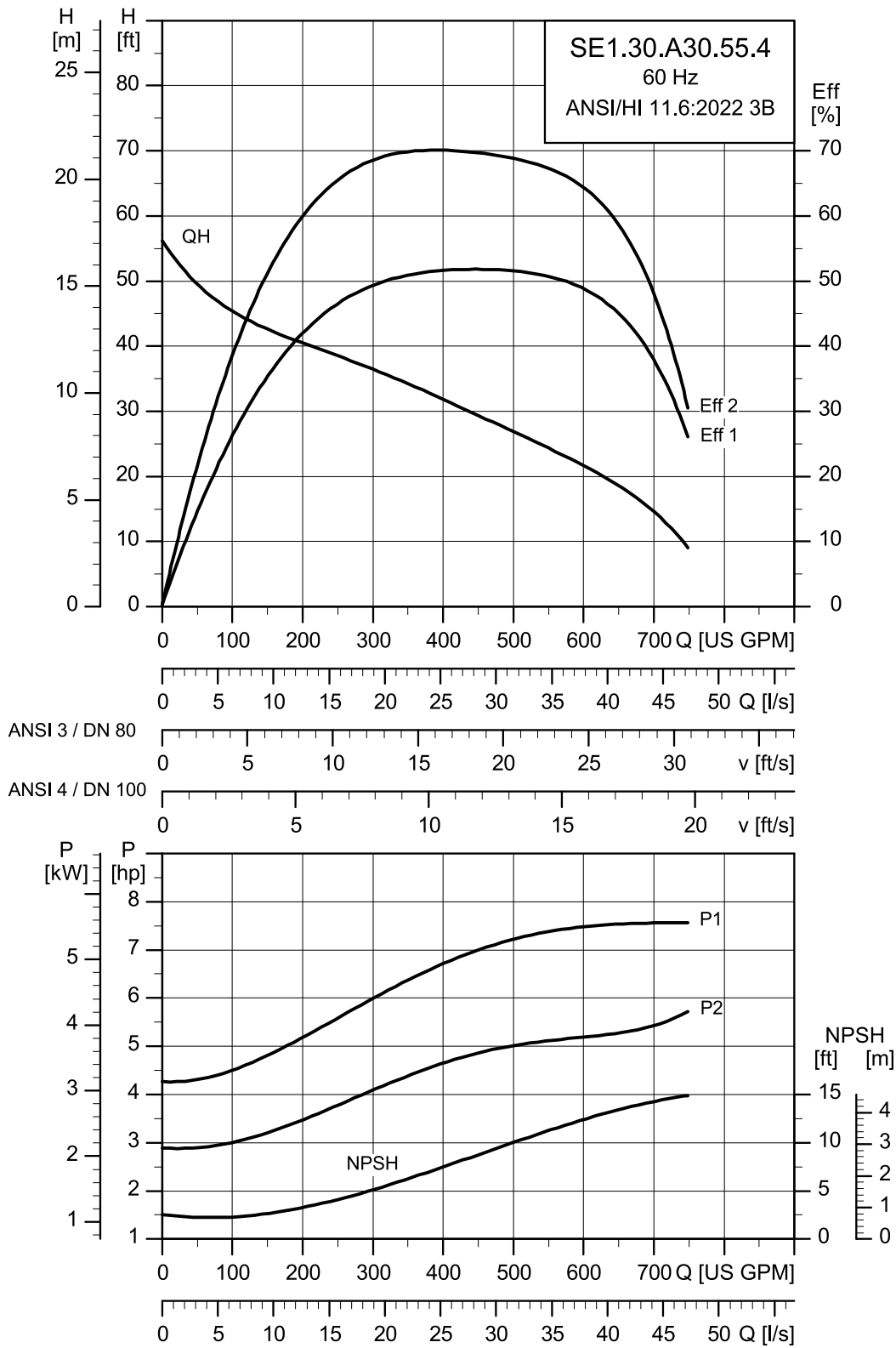

TM086464

Motor data

Pump type	Voltage [V]	P1 [Hp]	P2 [Hp]	No. of poles	RPM	Starting method	I _N [A]	I _{start} [A]	η _{motor} [%]			Cos φ		
									1/2	3/4	1/1	1/2	3/4	1/1
SE1.30.A30.55.A.EX.4.61R.B	230	6.365	5.5	4	1.741	Star-delta (YD)	14.04	84	86.8	86.9	85.5	0.72	0.8	0.83
	460								7.26	58.5	85.7	87.6	87.7	0.59

Pump data

Pump type	Impeller diameter [mm]	Moment of inertia (impeller) [kgm ²]	Outlet flange pressure (according to EN 1092-2)	Max. installation depth	Moment of inertia (motor) [kgm ²]	Breakdown torque M _{max} [Nm]
SE1.30.A30.55.A.EX.4.61R.B	221	0.04625	PN 10	12	0.01280	52
						71

SE1.30.A30.75.4

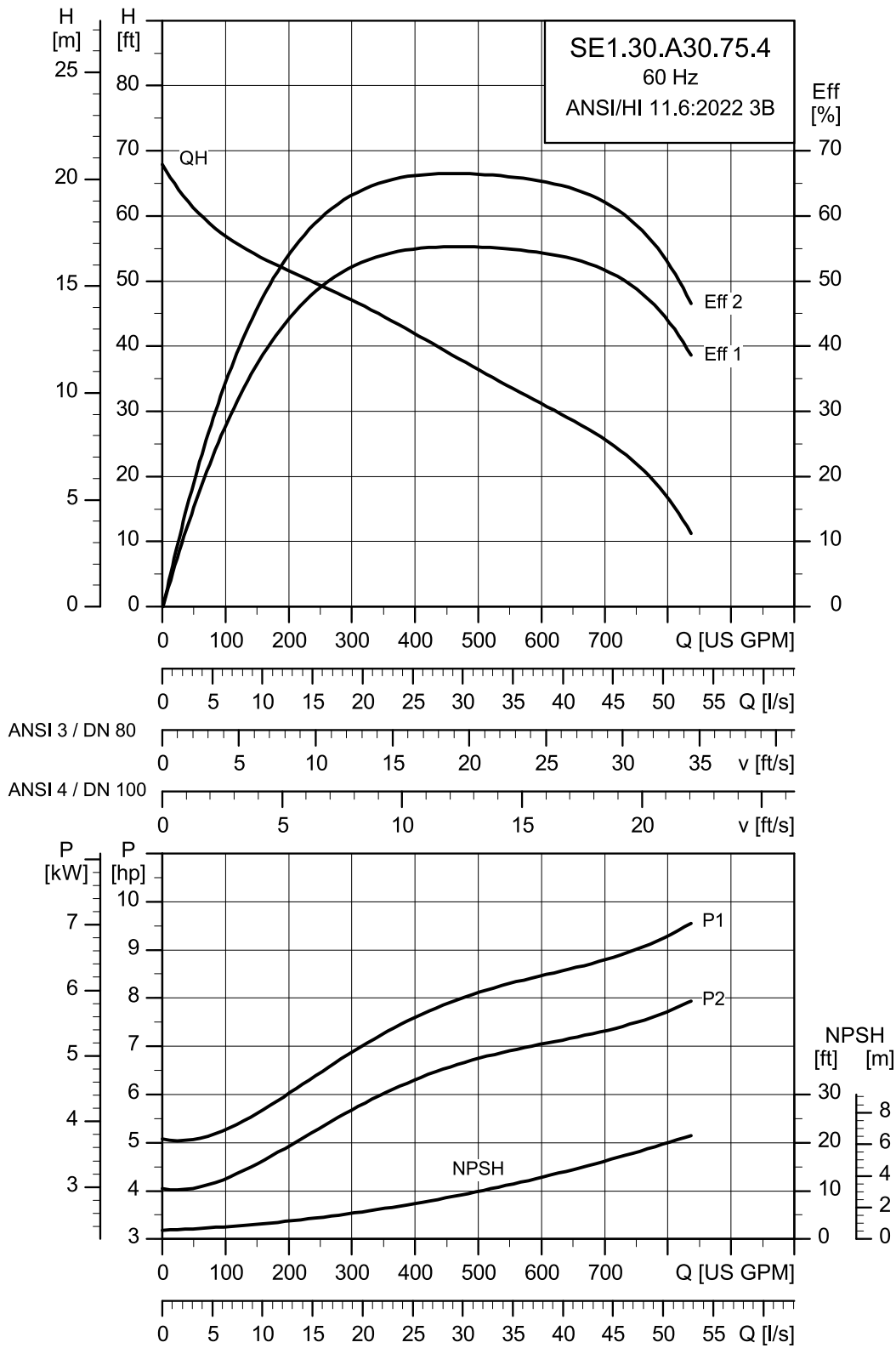

TM086465

Motor data

Pump type	Voltage [V]	P1 [Hp]	P2 [Hp]	No. of poles	RPM	Starting method	I _N [A]	I _{start} [A]	η _{motor} [%]			Cos φ		
									1/2	3/4	1/1	1/2	3/4	1/1
SE1.30.A30.75.A.EX.4.61R.B	230	8.857	7.5	4	1.727	Star-delta (YD)	19.1	120	86.4	86.6	85.1	0.69	0.8	0.85
	460								10.3	82.5	84.4	86.6	86.8	0.54

Pump data

Pump type	Impeller diameter [mm]	Moment of inertia (impeller) [kgm ²]	Outlet flange pressure (according to EN 1092-2)	Max. installation depth	Moment of inertia (motor) [kgm ²]	Breakdown torque M _{max} [Nm]
SE1.30.A30.75.A.EX.4.61R.B	200	0.05869	PN 10	12	0.01420	89 120

SE1.30.A30.100.4

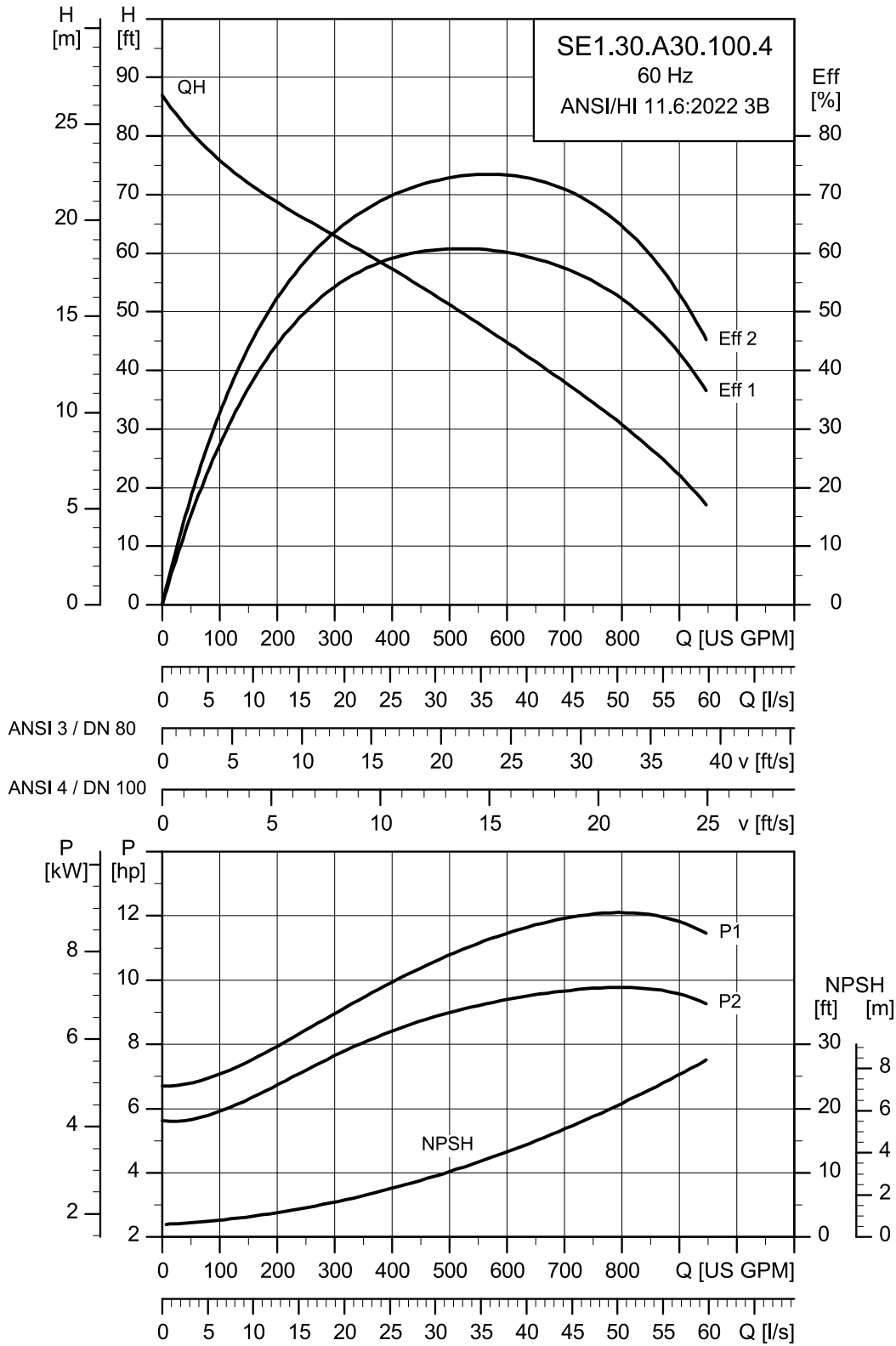

TM086460

Pump type	Voltage [V]	P1 [Hp]	P2 [Hp]	No. of poles	RPM	Starting method	I _N [A]	I _{start} [A]	η _{motor} [%]			Cos φ		
									1/2	3/4	1/1	1/2	3/4	1/1
SE1.30.A30.100.A.EX.4.61R.B	230	11.78	10	4	1.709	Star-delta (YD)	27.6	104	79.6	80.9	79.4	0.82	0.85	0.86
	460								13.4	78	79.3	82.5	83.2	0.71

Pump type	Impeller diameter [mm]	Moment of inertia (impeller) [kgm ²]	Outlet flange pressure (according to EN 1092-2)	Max. installation depth	Moment of inertia (motor) [kgm ²]	Breakdown torque M _{max} [Nm]
SE1.30.A30.100.A.EX.4.61R.B	224	0.08408	PN 10	12	0.02490	70
						99

SE1.30.A40.20.4

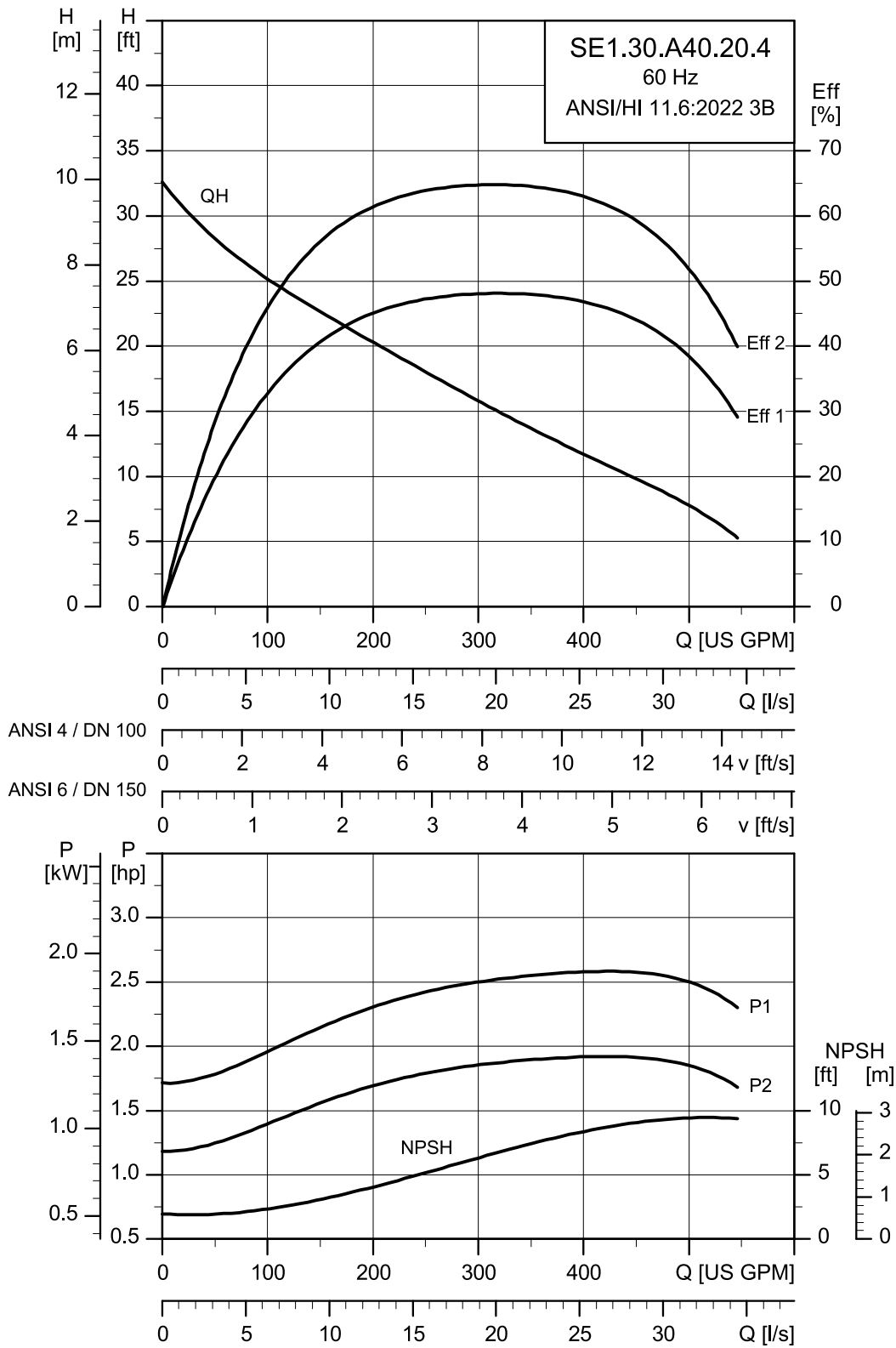

TM086467

Motor data

Pump type	Voltage [V]	P1 [Hp]	P2 [Hp]	No. of poles	RPM	Starting method	I _N [A]	I _{start} [A]	η _{motor} [%]			Cos φ		
									1/2	3/4	1/1	1/2	3/4	1/1
SE1.30.A40.20.A.EX.4.60R.B	230	2.704	2	4	1.703	Direct-on-line (DOL)	7.3	29.5	77.5	79	77.1	0.71	0.79	0.83
SE1.30.A40.20.A.EX.4.60H.B	460	2.704	2	4	1.739	Direct-on-line (DOL)	4.2	20.2	74.7	78.9	80	0.57	0.69	0.77

Pump data

Pump type	Impeller diameter [mm]	Moment of inertia (impeller) [kgm ²]	Outlet flange pressure (according to EN 1092-2)	Max. installation depth	Moment of inertia (motor) [kgm ²]	Breakdown torque M _{max} [Nm]
SE1.30.A40.20.A.EX.4.60R.B	152	0.01931	PN 10	12	0.00330	19.4
SE1.30.A40.20.A.EX.4.60H.B	152	0.01931	PN 10	12	0.00330	26.5

SE1.30.A40.30.4

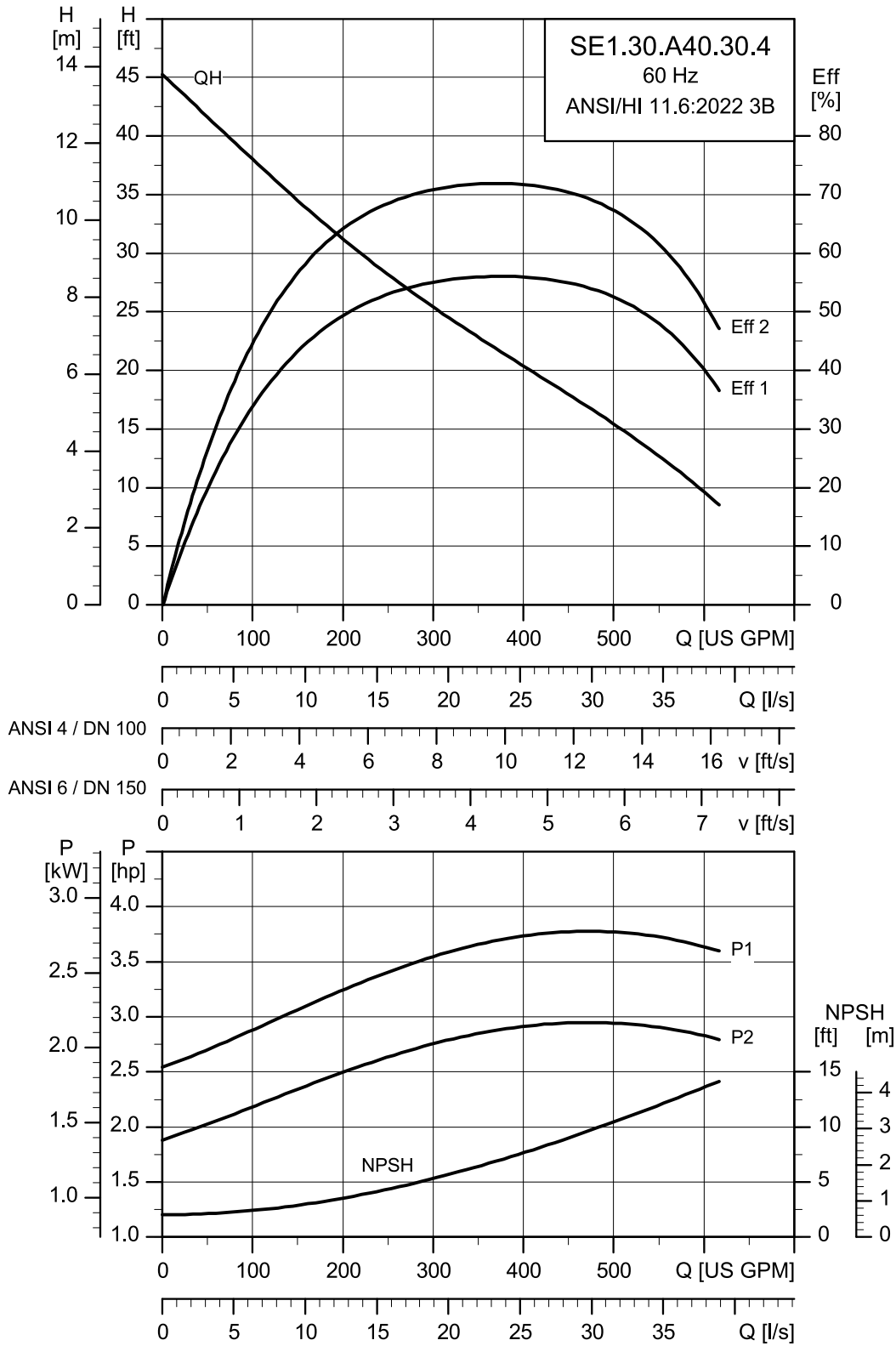

TM086468

Motor data

Pump type	Voltage [V]	P1 [Hp]	P2 [Hp]	No. of poles	RPM	Starting method	I _N [A]	I _{start} [A]	η _{motor} [%]			Cos φ		
									1/2	3/4	1/1	1/2	3/4	1/1
SE1.30.A40.30.A.EX.4.60R.B	230	3.776	3	4	1.717	Direct-on-line (DOL)	8.19	51.5	80.6	82.1	81	0.69	0.78	0.83
SE1.30.A40.30.A.EX.4.60H.B	460	3.776	3	4	1.743	Direct-on-line (DOL)	5.9	35.5	77.2	81.1	82.4	0.52	0.65	0.74

Pump data

Pump type	Impeller diameter [mm]	Moment of inertia (impeller) [kgm ²]	Outlet flange pressure (according to EN 1092-2)	Max. installation depth	Moment of inertia (motor) [kgm ²]	Breakdown torque M _{max} [Nm]
SE1.30.A40.30.A.EX.4.60R.B	172	0.03163	PN 10	12	0.00440	33.5
SE1.30.A40.30.A.EX.4.60H.B	172	0.03163	PN 10	12	0.00440	45.5

SE1.30.A40.40.4

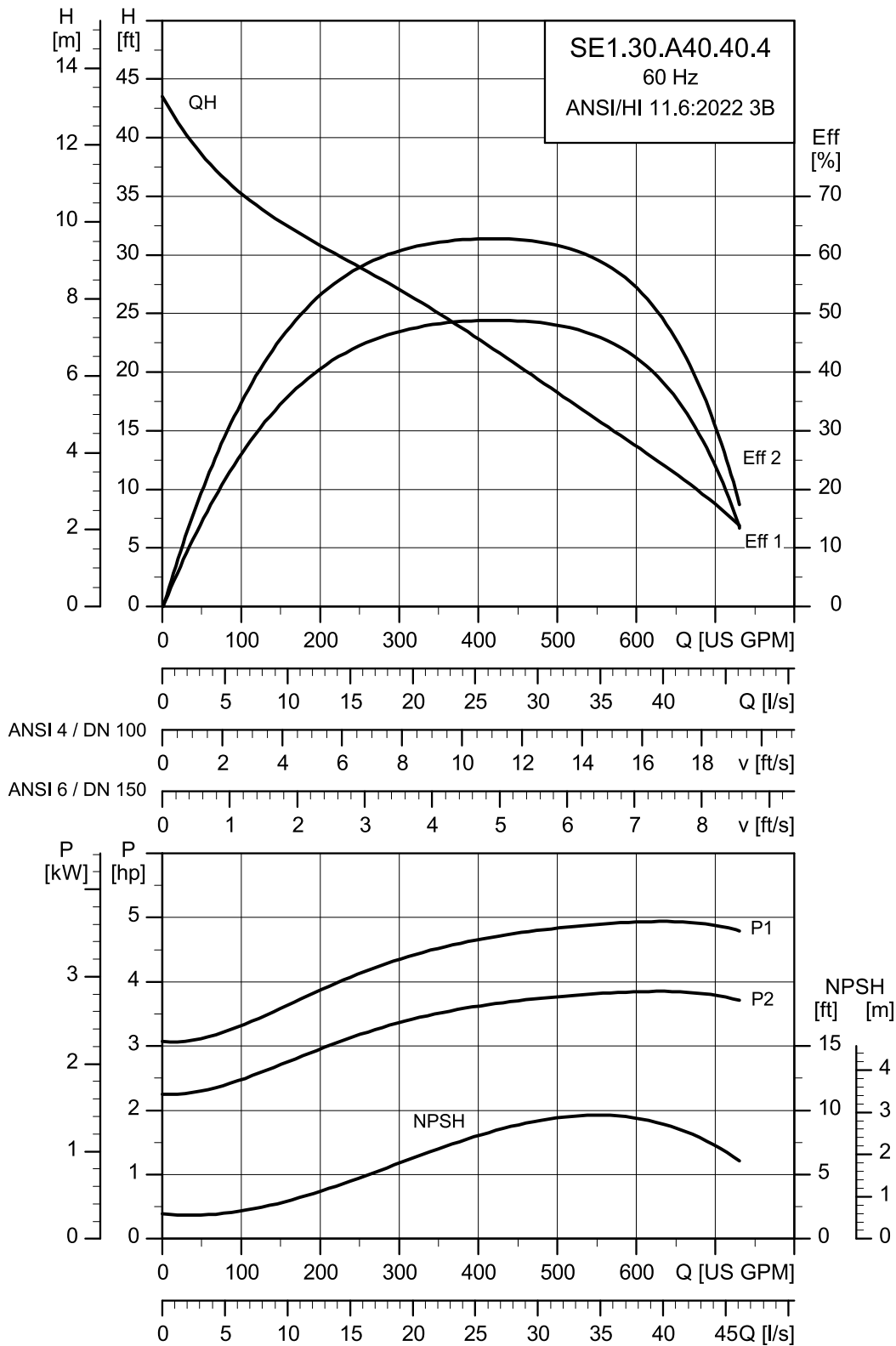

TM086469

Motor data

Pump type	Voltage [V]	P1 [Hp]	P2 [Hp]	No. of poles	RPM	Starting method	I _N [A]	I _{start} [A]	η _{motor} [%]			Cos φ		
									1/2	3/4	1/1	1/2	3/4	1/1
SE1.30.A40.40.A.EX.4.61R.B	230	5,155	4	4	1.739	Star-delta (YD)	10,59	68	84,7	85,6	84,8	0,69	0,79	0,83
	460								82,6	85,5	86,3	0,55	0,68	0,76

Pump data

Pump type	Impeller diameter [mm]	Moment of inertia (impeller) [kgm ²]	Outlet flange pressure (according to EN 1092-2)	Max. installation depth	Moment of inertia (motor) [kgm ²]	Breakdown torque M _{max} [Nm]
SE1.30.A40.40.A.EX.4.61R.B	171	0,03829	PN 10	12	0,01040	47.5 64.5

SE1.30.A40.55.4

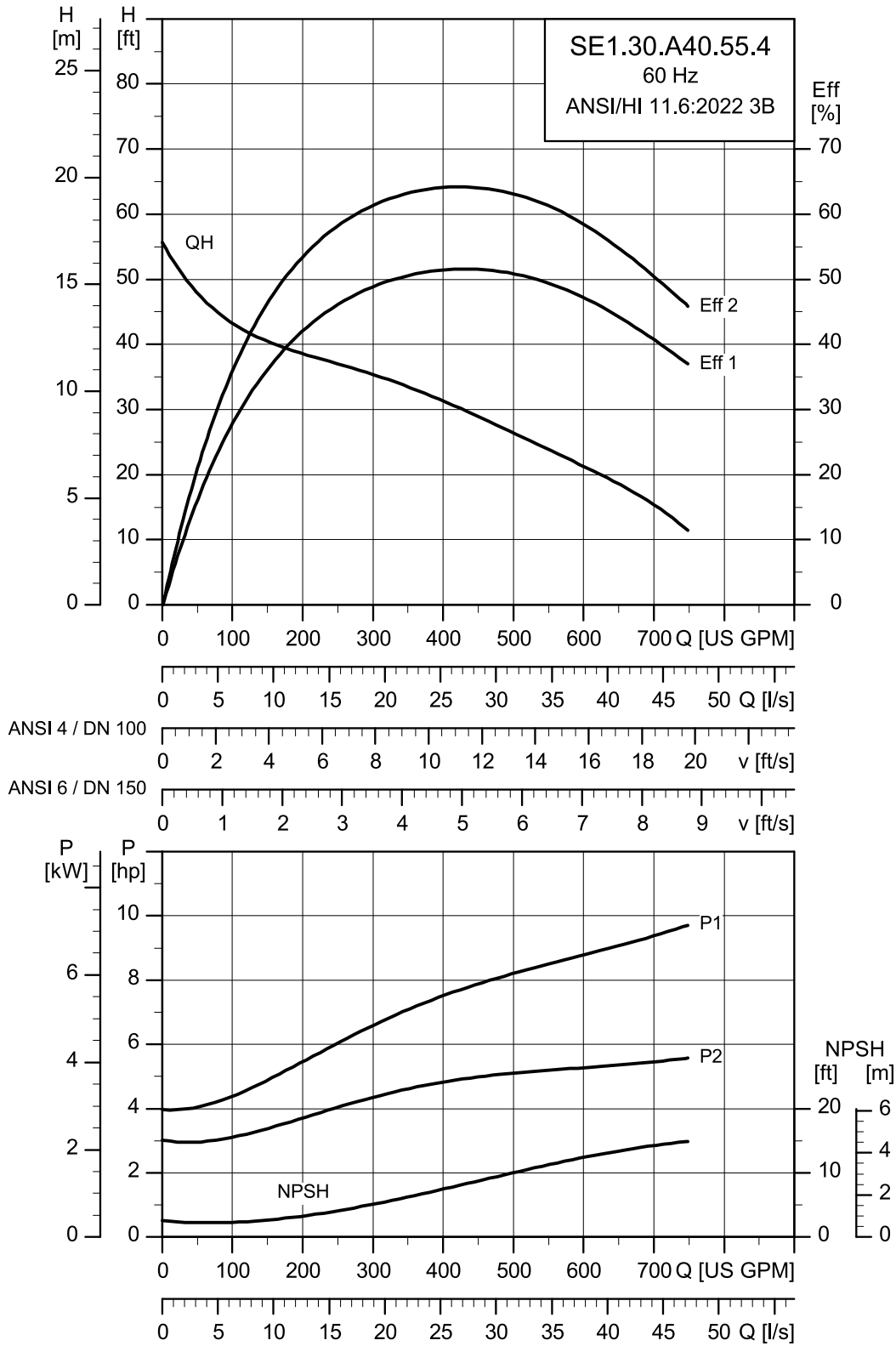

TM086470

Motor data

Pump type	Voltage [V]	P1 [Hp]	P2 [Hp]	No. of poles	RPM	Starting method	I _N [A]	I _{start} [A]	η _{motor} [%]			Cos φ		
									1/2	3/4	1/1	1/2	3/4	1/1
SE1.30.A40.55.A.EX.4.61R.B	230	6.641	5.5	4	1.741	Star-delta (YD)	14.04	84	86.8	86.9	85.5	0.72	0.8	0.83
	460								7.26	58.5	85.7	87.6	87.7	0.59

Pump data

Pump type	Impeller diameter [mm]	Moment of inertia (impeller) [kgm ²]	Outlet flange pressure (according to EN 1092-2)	Max. installation depth	Moment of inertia (motor) [kgm ²]	Breakdown torque M _{max} [Nm]
SE1.30.A40.55.A.EX.4.61R.B	221	0.04600	PN 10	12	0.01280	52 71

SE1.30.A40.75.4

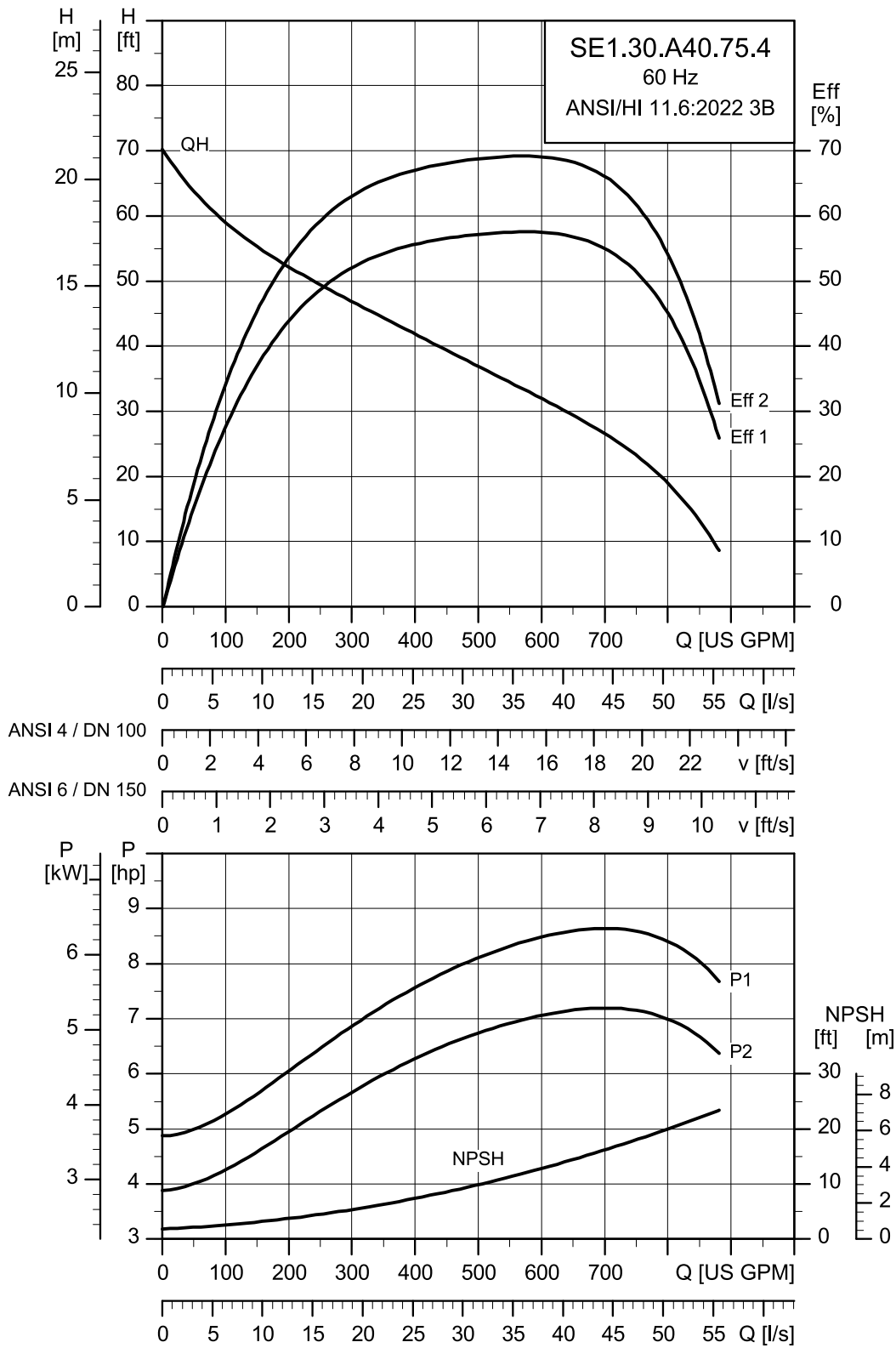

TM086471

Motor data

Pump type	Voltage [V]	P1 [Hp]	P2 [Hp]	No. of poles	RPM	Starting method	I _N [A]	I _{start} [A]	η _{motor} [%]			Cos φ		
									1/2	3/4	1/1	1/2	3/4	1/1
SE1.30.A40.75.A.EX.4.61R.B	230	8.855	7.5	4	1.727	Star-delta (YD)	19.1	120	86.4	86.6	85.1	0.69	0.8	0.85
	460								10.3	82.5	84.4	86.6	86.8	0.54

Pump data

Pump type	Impeller diameter [mm]	Moment of inertia (impeller) [kgm ²]	Outlet flange pressure (according to EN 1092-2)	Max. installation depth	Moment of inertia (motor) [kgm ²]	Breakdown torque M _{max} [Nm]
SE1.30.A40.75.A.EX.4.61R.B	200	0.05869	PN 10	12	0.01420	89 120

SE1.30.A40.100.4

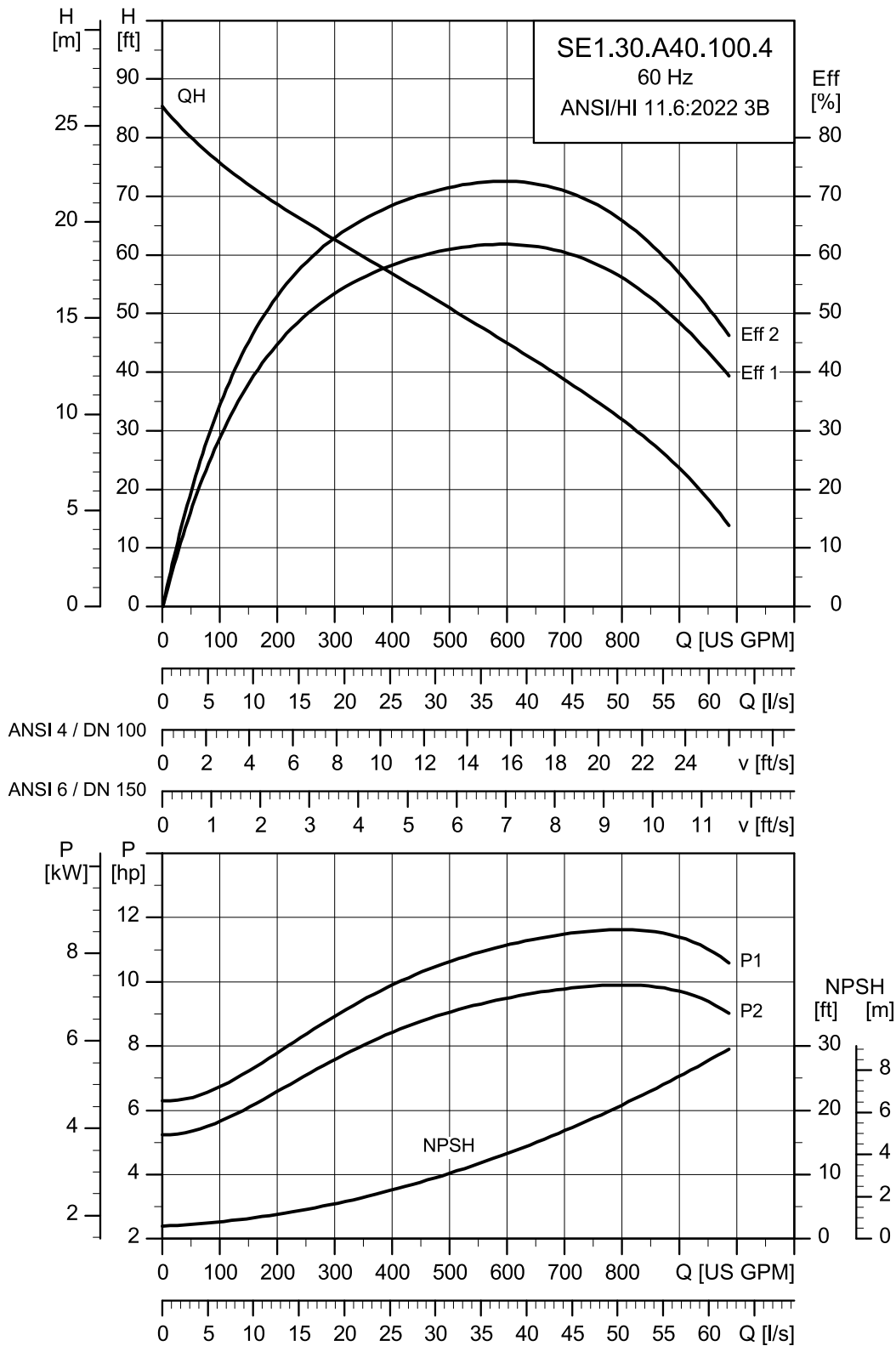

TM086466

Motor data

Pump type	Voltage [V]	P1 [Hp]	P2 [Hp]	No. of poles	RPM	Starting method	I _N [A]	I _{start} [A]	η _{motor} [%]			Cos φ		
									1/2	3/4	1/1	1/2	3/4	1/1
SE1.30.A40.100.A.EX.4.61R.B	230	11.8	10	4	1.709	Star-delta (YD)	27.6	104	79.6	80.9	79.4	0.82	0.85	0.86
	460								13.4	78	79.3	82.5	83.2	0.71

Pump data

Pump type	Impeller diameter [mm]	Moment of inertia (impeller) [kgm ²]	Outlet flange pressure (according to EN 1092-2)	Max. installation depth	Moment of inertia (motor) [kgm ²]	Breakdown torque M _{max} [Nm]
SE1.30.A40.100.A.EX.4.61R.B	224	0.08408	PN 10	12	0.02490	70 99

SE1.40.A40.55.4

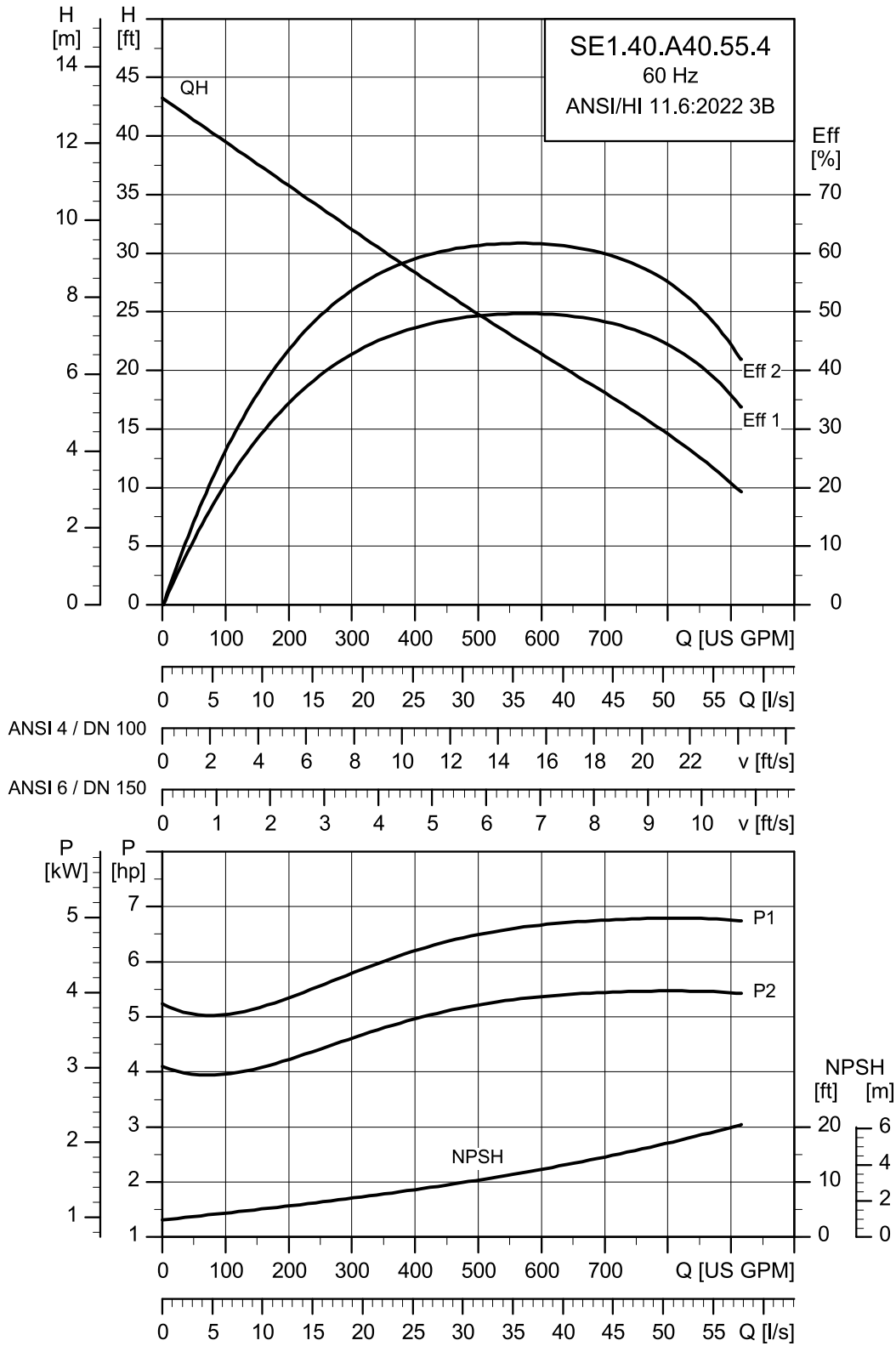

TM086473

Motor data

Pump type	Voltage [V]	P1 [Hp]	P2 [Hp]	No. of poles	RPM	Starting method	I _N [A]	I _{start} [A]	η _{motor} [%]			Cos φ		
									1/2	3/4	1/1	1/2	3/4	1/1
SE1.40.A40.55.A.EX.4.61R.B	230	6.643	5.5	4	1.741	Star-delta (YD)	14.04	84	86.8	86.9	85.5	0.72	0.8	0.83
	460								7.26	58.5	85.7	87.6	87.7	0.59

Pump data

Pump type	Impeller diameter [mm]	Moment of inertia (impeller) [kgm ²]	Outlet flange pressure (according to EN 1092-2)	Max. installation depth	Moment of inertia (motor) [kgm ²]	Breakdown torque M _{max} [Nm]
SE1.40.A40.55.A.EX.4.61R.B	181	0.06320	PN 10	12	0.01280	52
						71

SE1.40.A40.75.4

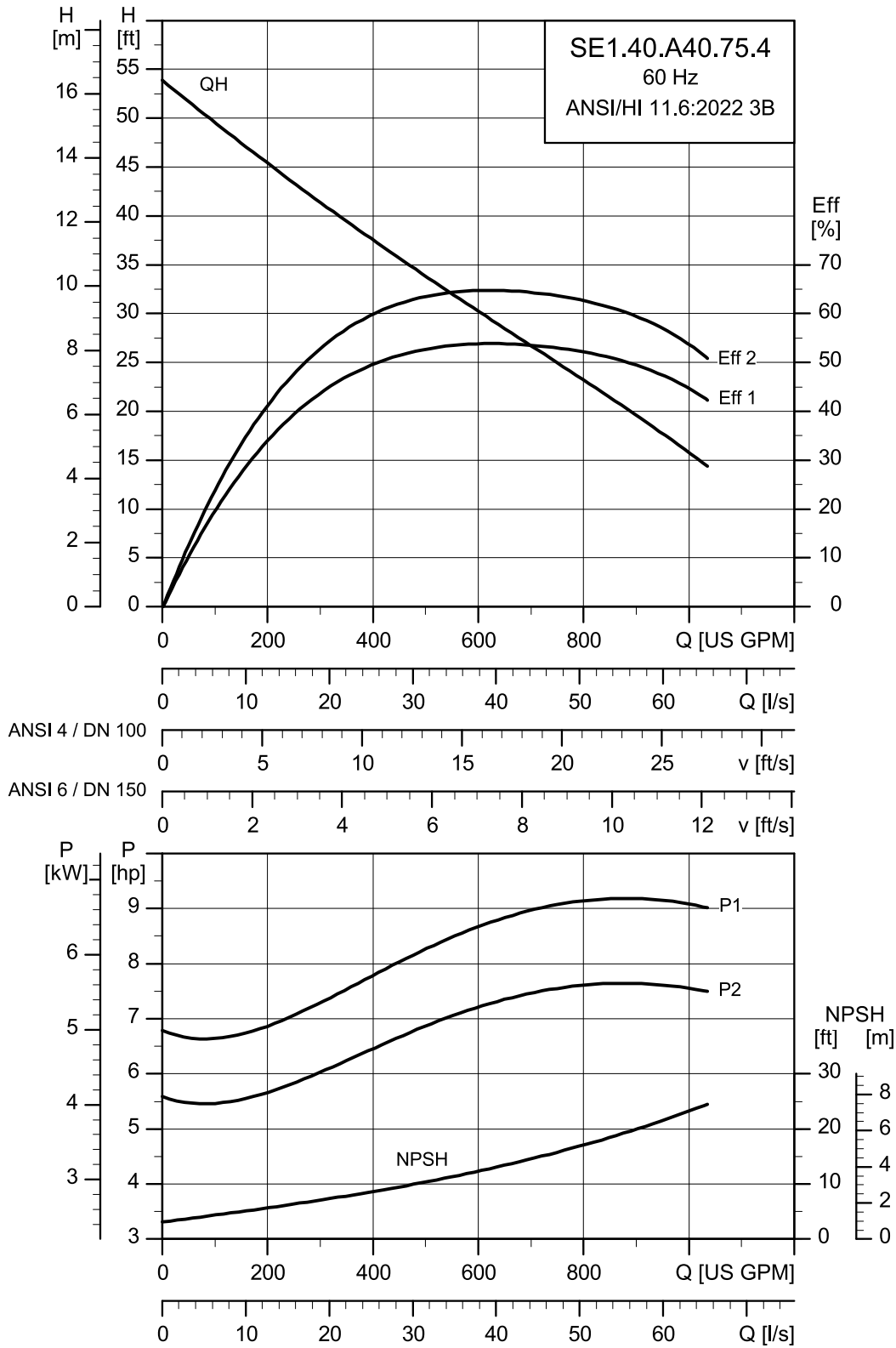

TM086474

Motor data

Pump type	Voltage [V]	P1 [Hp]	P2 [Hp]	No. of poles	RPM	Starting method	I _N [A]	I _{start} [A]	η _{motor} [%]			Cos φ		
									1/2	3/4	1/1	1/2	3/4	1/1
SE1.40.A40.75.A.EX.4.61R.B	230	8.858	7.5	4	1.727	Star-delta (YD)	19.1	120	86.4	86.6	85.1	0.69	0.8	0.85
	460								10.3	82.5	84.4	86.6	86.8	0.54

Pump data

Pump type	Impeller diameter [mm]	Moment of inertia (impeller) [kgm ²]	Outlet flange pressure (according to EN 1092-2)	Max. installation depth	Moment of inertia (motor) [kgm ²]	Breakdown torque M _{max} [Nm]
SE1.40.A40.75.A.EX.4.61R.B	196	0.07415	PN 10	12	0.01420	89 120

SE1.40.A40.100.4

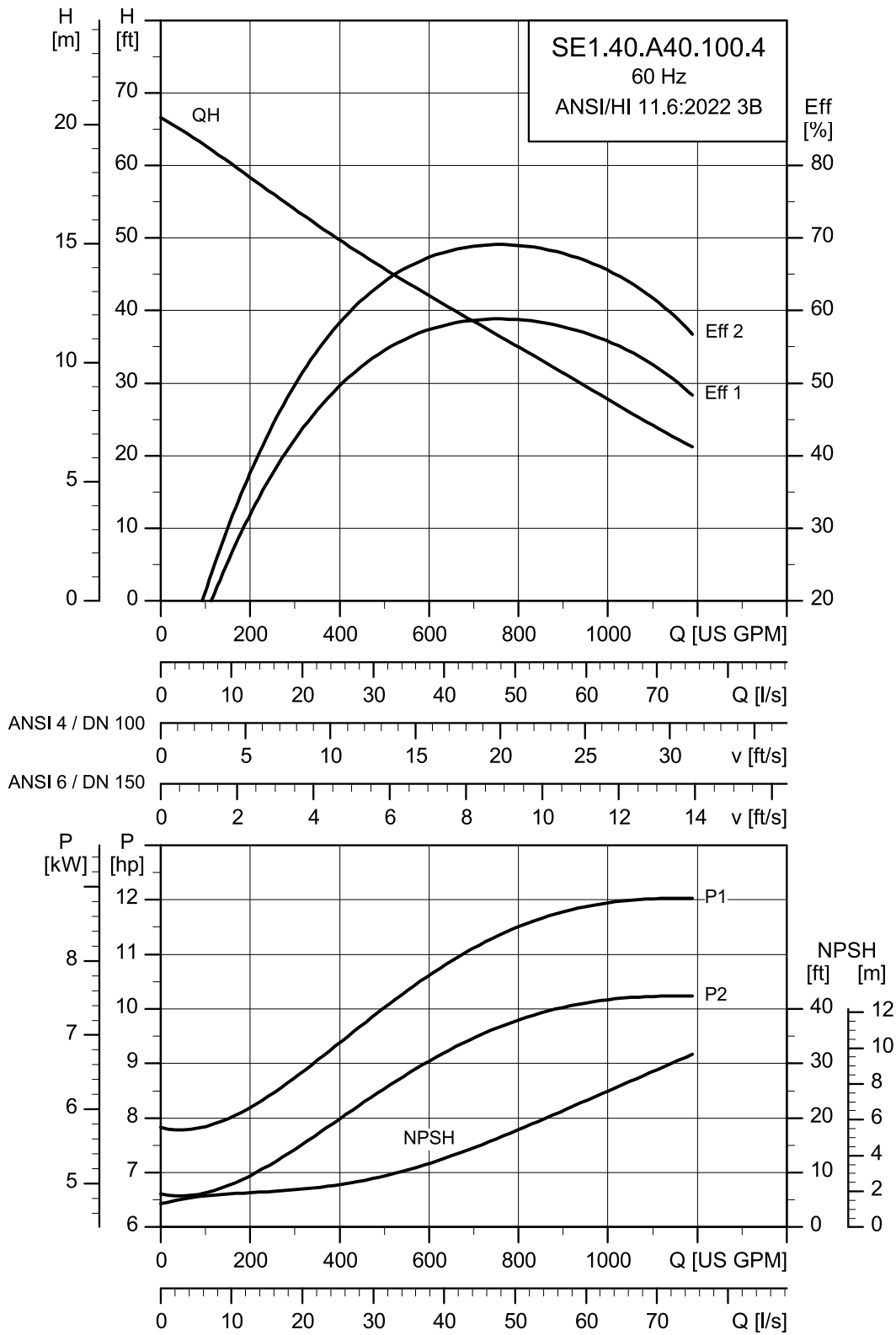

TM086472

Motor data

Pump type	Voltage [V]	P1 [Hp]	P2 [Hp]	No. of poles	RPM	Starting method	I _N [A]	I _{start} [A]	η _{motor} [%]			Cos φ		
									1/2	3/4	1/1	1/2	3/4	1/1
SE1.40.A40.100.A.EX.4.61R.B	230	11.799	10	4	1.709	Star-delta (YD)	27.6	104	79.6	80.9	79.4	0.82	0.85	0.86
	460								13.4	78	79.3	82.5	83.2	0.71

Pump data

Pump type	Impeller diameter [mm]	Moment of inertia (impeller) [kgm ²]	Outlet flange pressure (according to EN 1092-2)	Max. installation depth	Moment of inertia (motor) [kgm ²]	Breakdown torque M _{max} [Nm]
SE1.40.A40.100.A.EX.4.61R.B	210	0.08149	PN 10	12	0.02490	70 99

SE1.40.A60.55.4

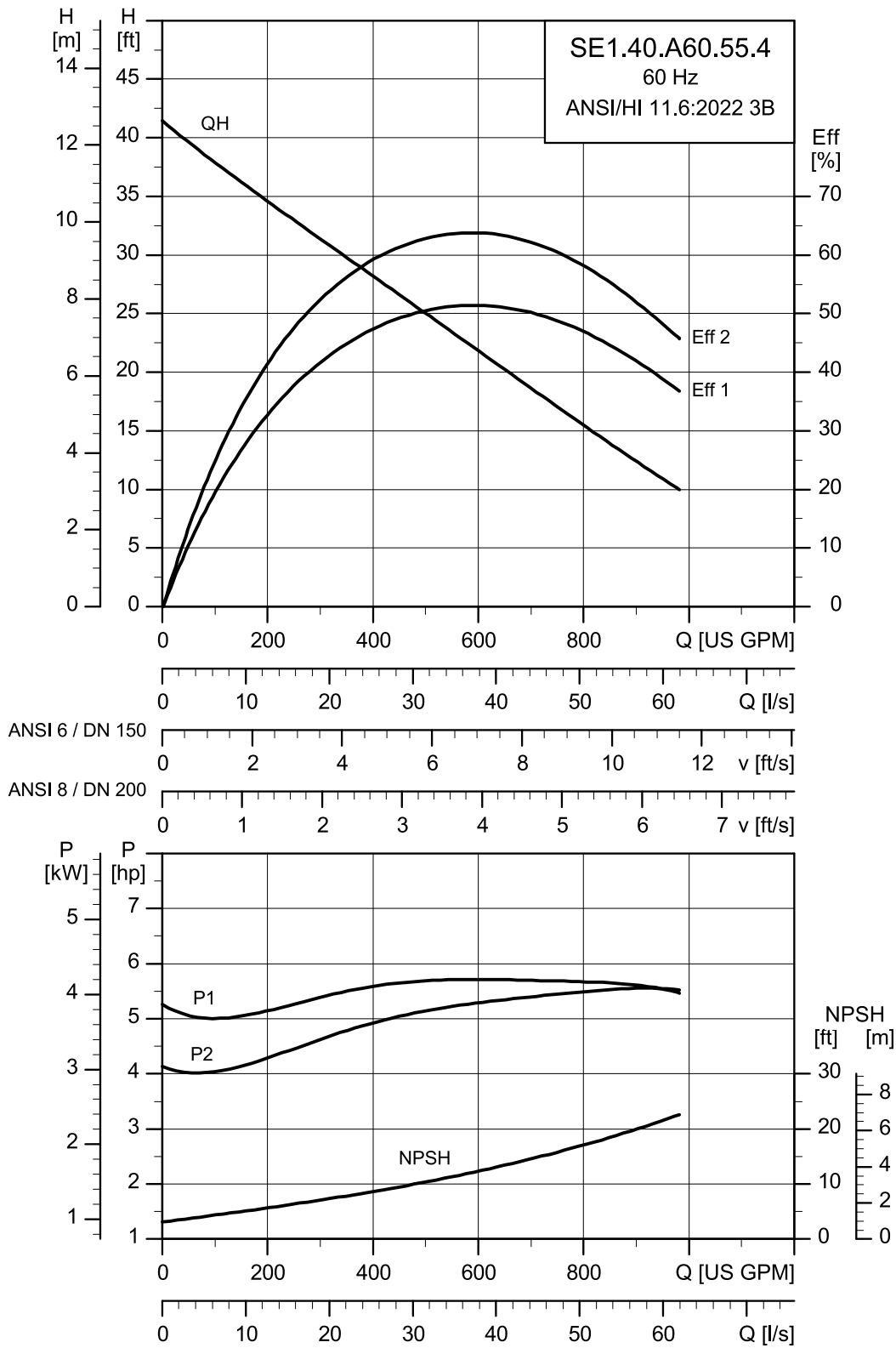

TM086476

Motor data

Pump type	Voltage [V]	P1 [Hp]	P2 [Hp]	No. of poles	RPM	Starting method	I _N [A]	I _{start} [A]	η _{motor} [%]			Cos φ		
									1/2	3/4	1/1	1/2	3/4	1/1
SE1.40.A60.55.A.EX.4.61R.B	230	6,294	5,5	4	1.741	Star-delta (YD)	14,04	84	86,8	86,9	85,5	0,72	0,8	0,83
	460								7,26	58,5	85,7	87,6	87,7	0,59

Pump data

Pump type	Impeller diameter [mm]	Moment of inertia (impeller) [kgm ²]	Outlet flange pressure (according to EN 1092-2)	Max. installation depth	Moment of inertia (motor) [kgm ²]	Breakdown torque M _{max} [Nm]
SE1.40.A60.55.A.EX.4.61R.B	181	0,06320	PN 10	12	0,01280	52
						71

SE1.40.A60.75.4

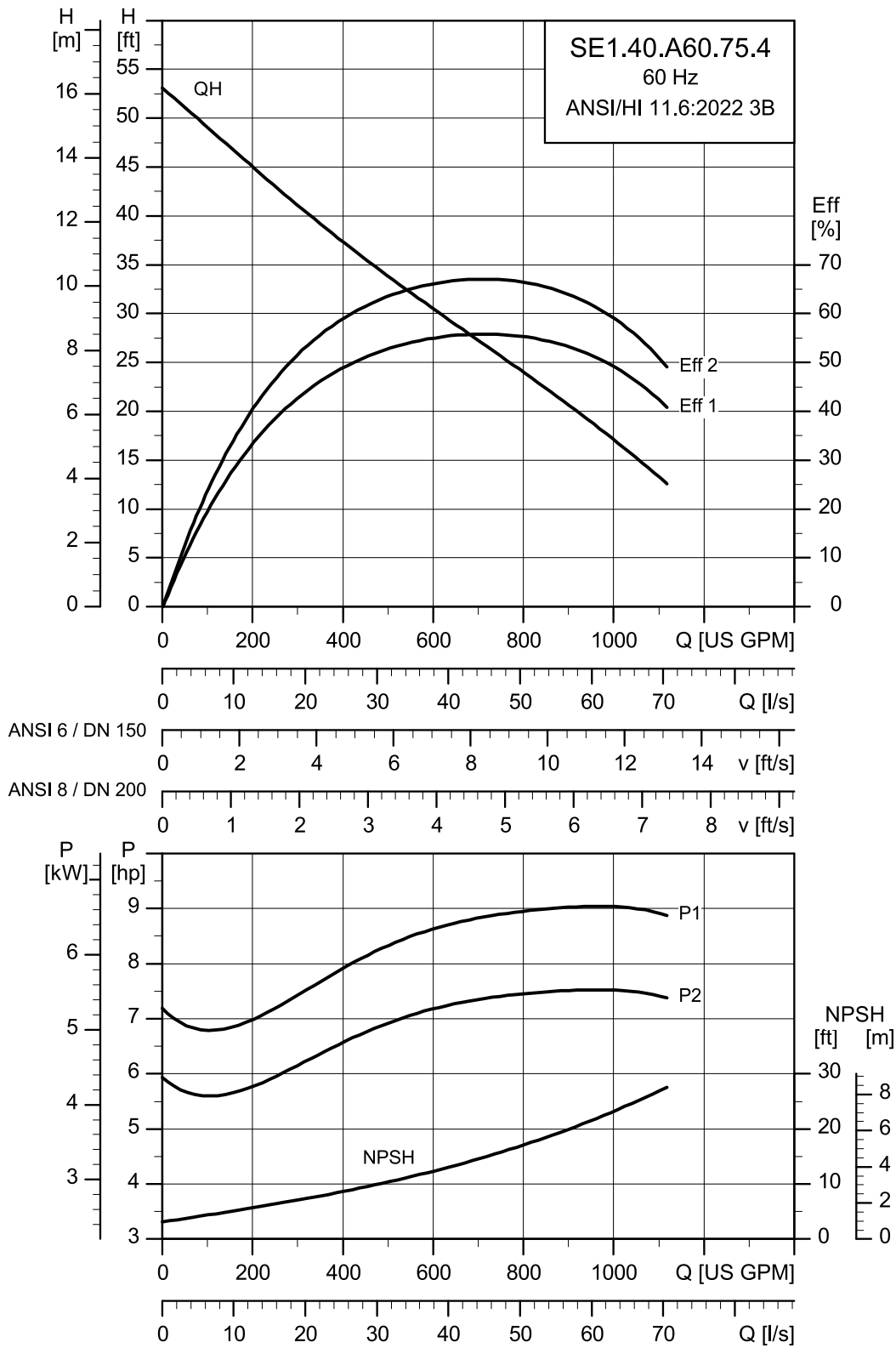

TM086477

Motor data

Pump type	Voltage [V]	P1 [Hp]	P2 [Hp]	No. of poles	RPM	Starting method	I _N [A]	I _{start} [A]	η _{motor} [%]			Cos φ		
									1/2	3/4	1/1	1/2	3/4	1/1
SE1.40.A60.75.A.EX.4.61R.B	230	8,653	7,5	4	1.727	Star-delta (YD)	19,1	120	86,4	86,6	85,1	0,69	0,8	0,85
	460								10,3	82,5	84,4	86,6	86,8	0,54

Pump data

Pump type	Impeller diameter [mm]	Moment of inertia (impeller) [kgm ²]	Outlet flange pressure (according to EN 1092-2)	Max. installation depth	Moment of inertia (motor) [kgm ²]	Breakdown torque M _{max} [Nm]
SE1.40.A60.75.A.EX.4.61R.B	196	0,07415	PN 10	12	0,01420	89 120

SE1.40.A60.100.4

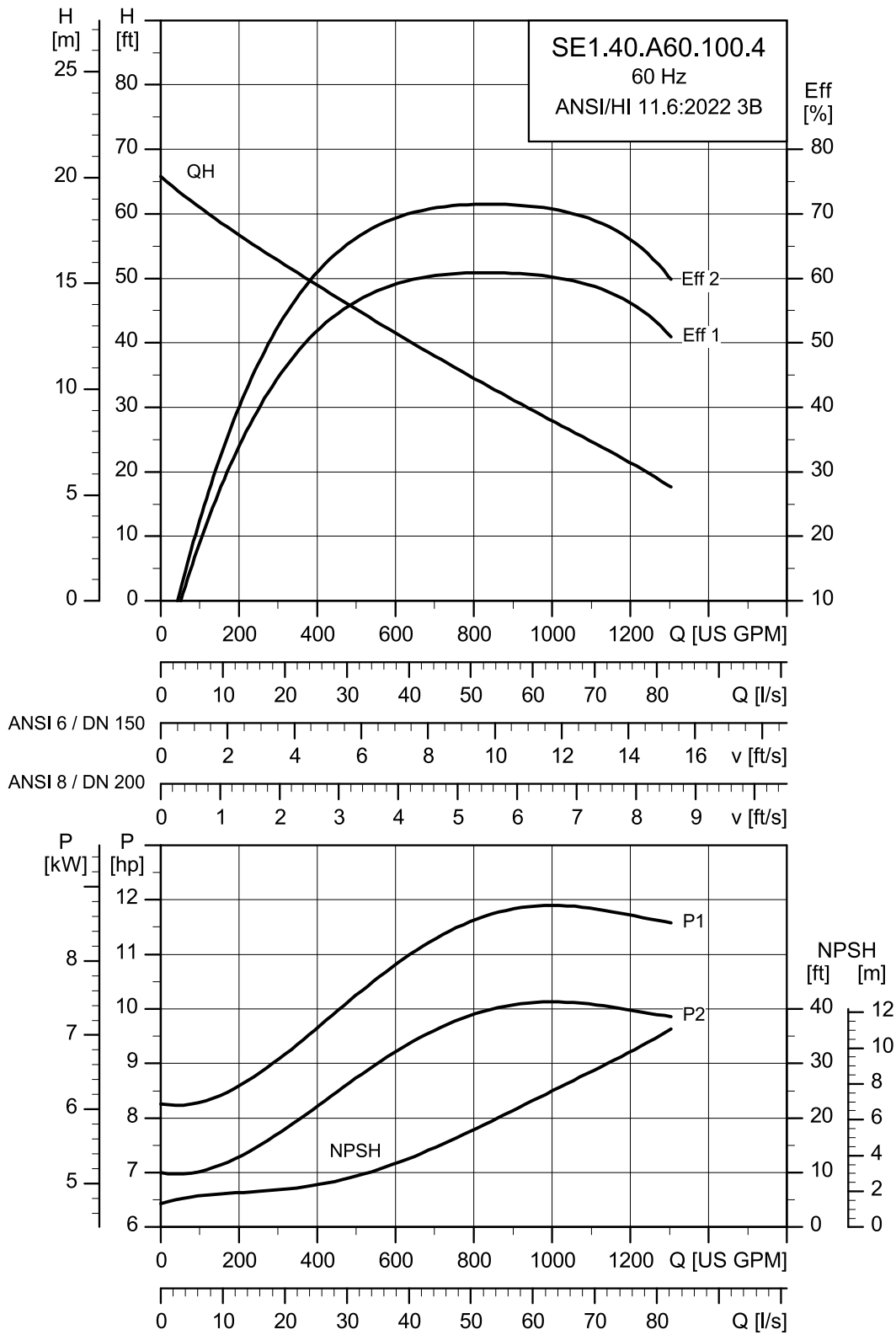

TM086475

Motor data

Pump type	Voltage [V]	P1 [Hp]	P2 [Hp]	No. of poles	RPM	Starting method	I _N [A]	I _{start} [A]	η _{motor} [%]			Cos φ		
									1/2	3/4	1/1	1/2	3/4	1/1
SE1.40.A60.100.A.EX.4.61R.B	230	11,799	10	4	1.709	Star-delta (YD)	27,6	104	79,6	80,9	79,4	0,82	0,85	0,86
	460								13,4	78	79,3	82,5	83,2	0,71

Pump data

Pump type	Impeller diameter [mm]	Moment of inertia (impeller) [kgm ²]	Outlet flange pressure (according to EN 1092-2)	Max. installation depth	Moment of inertia (motor) [kgm ²]	Breakdown torque M _{max} [Nm]
SE1.40.A60.100.A.EX.4.61R.B	210	0,08149	PN 10	12	0,02490	70 99

SEV.25.A25.30.2.6

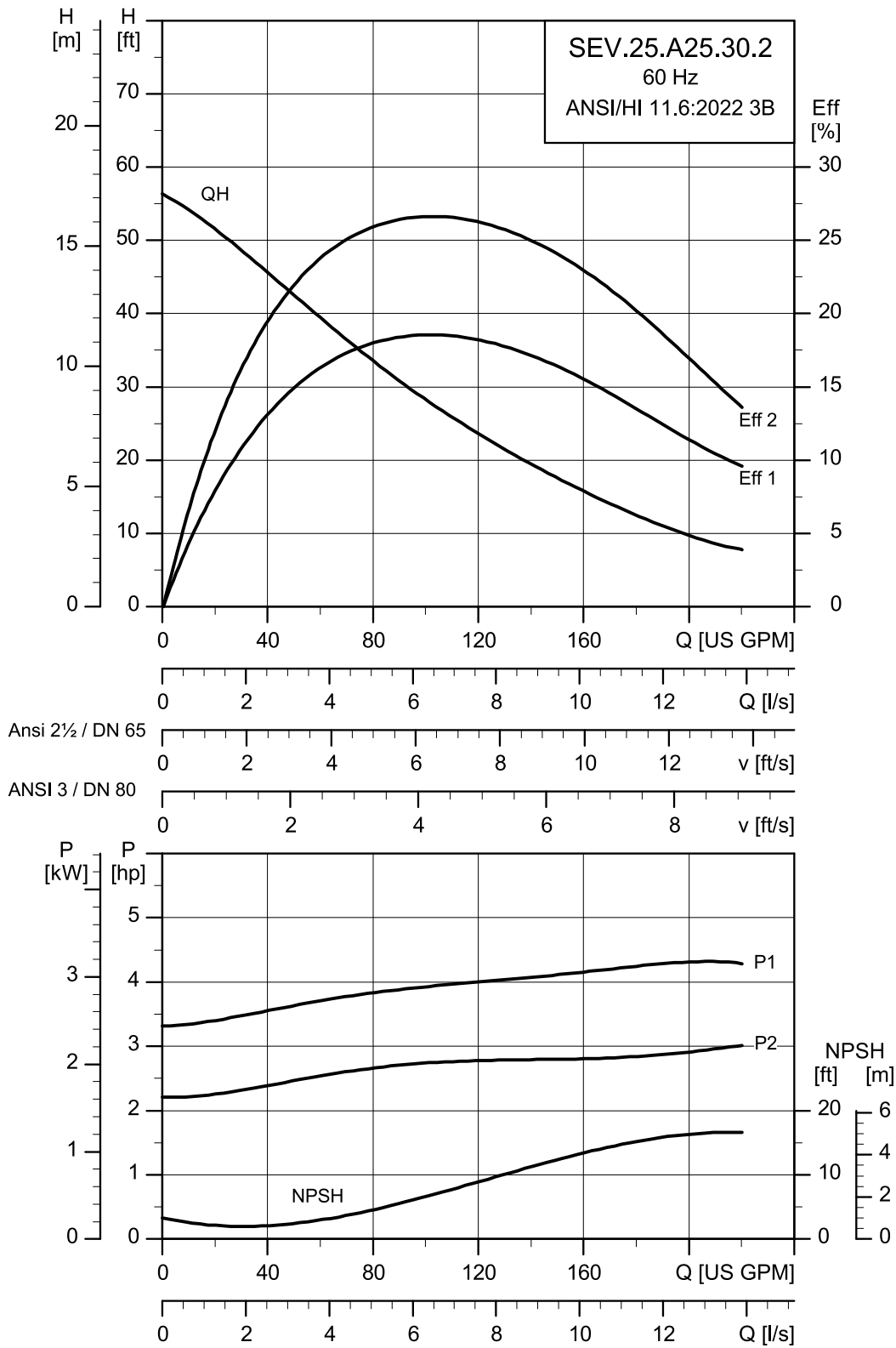

TM086478

Motor data

Pump type	Voltage [V]	P1 [Hp]	P2 [Hp]	No. of poles	RPM	Starting method	I _N [A]	I _{start} [A]	η _{motor} [%]			Cos φ		
									1/2	3/4	1/1	1/2	3/4	1/1
SEV.25.A25.30.A.EX.2.60R	230	4.193	3	2	3.472	Direct-on-line (DOL)	8.7	50	80.5	82.6	82.3	0.83	0.88	0.9
SEV.25.A25.30.A.EX.2.60H	460	4.193	3	2	3.510	Direct-on-line (DOL)	5	34.5	78.4	82.4	83.7	0.7	0.8	0.85

Pump data

Pump type	Impeller diameter [mm]	Moment of inertia (impeller) [kgm ²]	Outlet flange pressure (according to EN 1092-2)	Max. installation depth	Moment of inertia (motor) [kgm ²]	Breakdown torque M _{max} [Nm]
SEV.25.A25.30.A.EX.2.60R	128.3	0.00303	PN 10	12	0.00190	14.6
SEV.25.A25.30.A.EX.2.60H	128.3	0.00303	PN 10	12	0.00190	21.8

SEV.25.A25.40.2.6

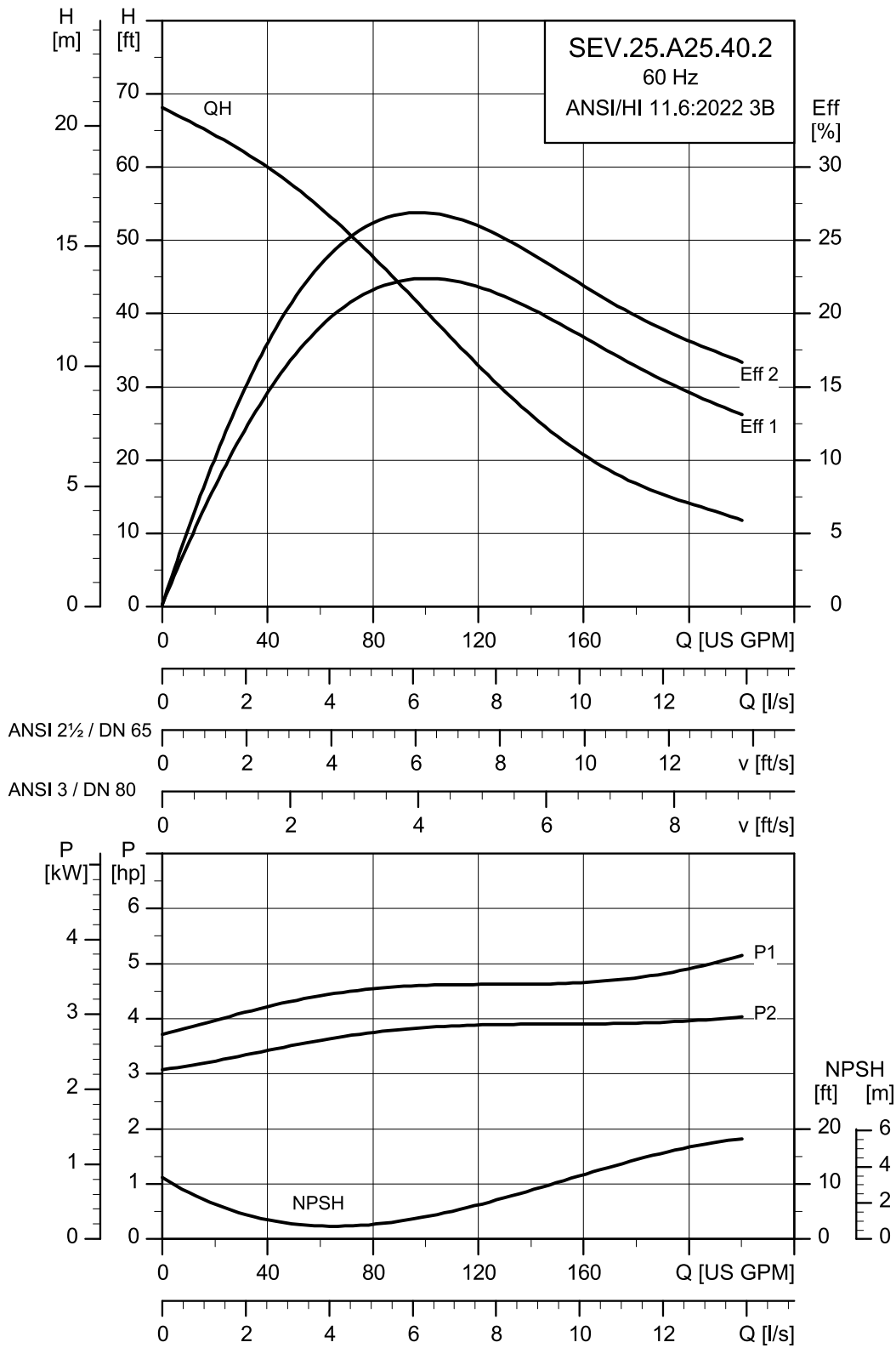

TM086479

Motor data

Pump type	Voltage [V]	P1 [Hp]	P2 [Hp]	No. of poles	RPM	Starting method	I _N [A]	I _{start} [A]	η _{motor} [%]			Cos φ		
									1/2	3/4	1/1	1/2	3/4	1/1
SEV.25.A25.40.A.EX.2.60R	230	4.769	4	2	3.463	Direct-on-line (DOL)	10.14	66	81.2	82.9	82.1	0.85	0.89	0.91
SEV.25.A25.40.A.EX.2.60H	460	4.769	4	2	3.506	Direct-on-line (DOL)	5.07	46	79.9	83.4	84.3	0.77	0.85	0.88

Pump data

Pump type	Impeller diameter [mm]	Moment of inertia (impeller) [kgm ²]	Outlet flange pressure (according to EN 1092-2)	Max. installation depth	Moment of inertia (motor) [kgm ²]	Breakdown torque M _{max} [Nm]
SEV.25.A25.40.A.EX.2.60R	129	0.00346	PN 10	12	0.00260	16.4
SEV.25.A25.40.A.EX.2.60H	129	0.00346	PN 10	12	0.00260	23.4

SEV.25.A25.55.2.6

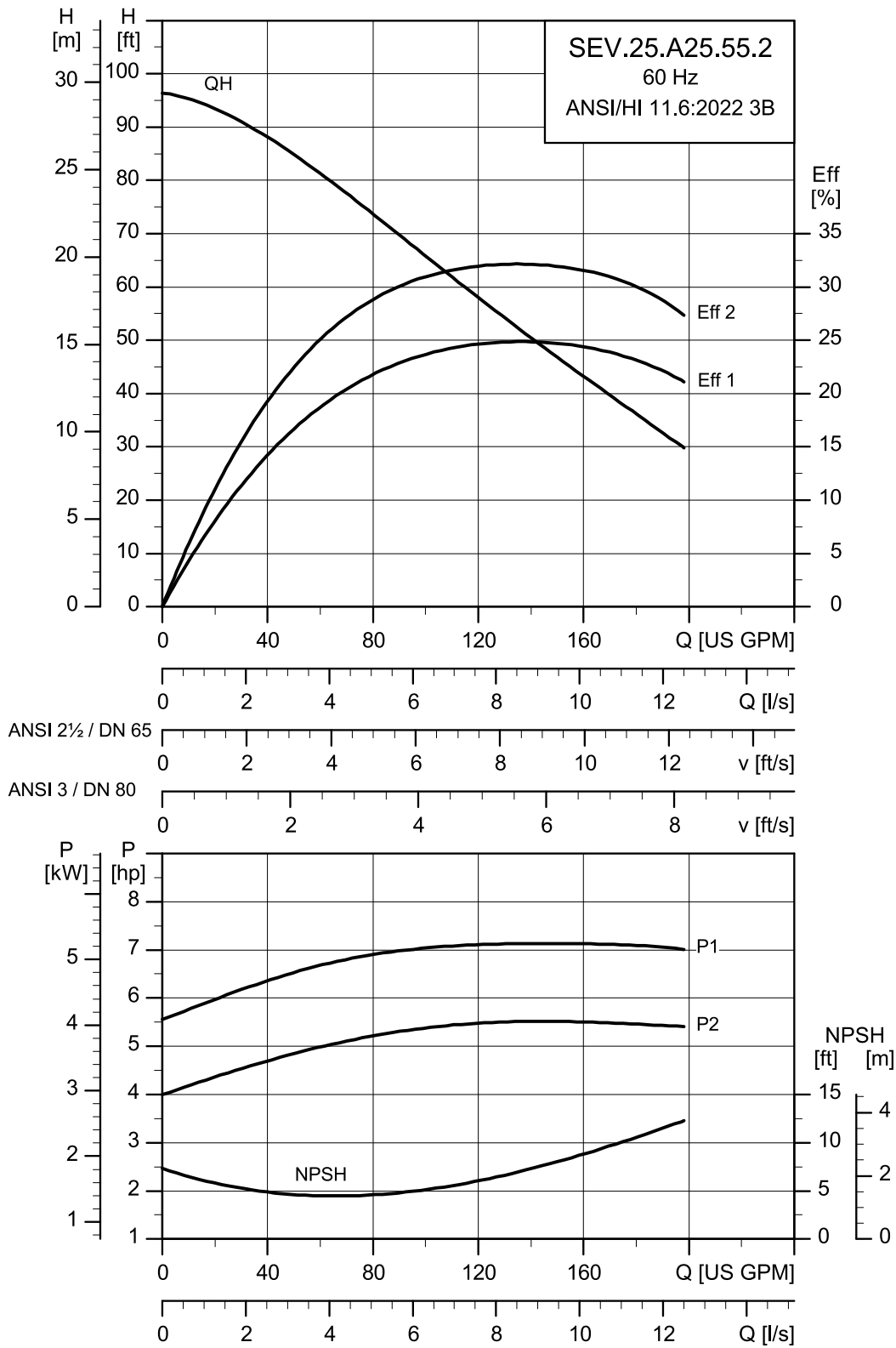

TM086480

Motor data

Pump type	Voltage [V]	P1 [Hp]	P2 [Hp]	No. of poles	RPM	Starting method	I _N [A]	I _{start} [A]	η _{motor} [%]			Cos φ		
									1/2	3/4	1/1	1/2	3/4	1/1
SEV.25.A25.55.A.EX.2.61R	230	6.93	5.5	2	3.485	Star-delta (YD)	13.05	93.5	84.5	86	85.6	0.82	0.88	0.9
	460								6.7	63.5	83.5	86.3	87.1	0.71

Pump data

Pump type	Impeller diameter [mm]	Moment of inertia (impeller) [kgm ²]	Outlet flange pressure (according to EN 1092-2)	Max. installation depth	Moment of inertia (motor) [kgm ²]	Breakdown torque M _{max} [Nm]
SEV.25.A25.55.A.EX.2.61R	149	0.00600	PN 10	12	0.00540	31 45.5

SEV.25.A30.30.2.6

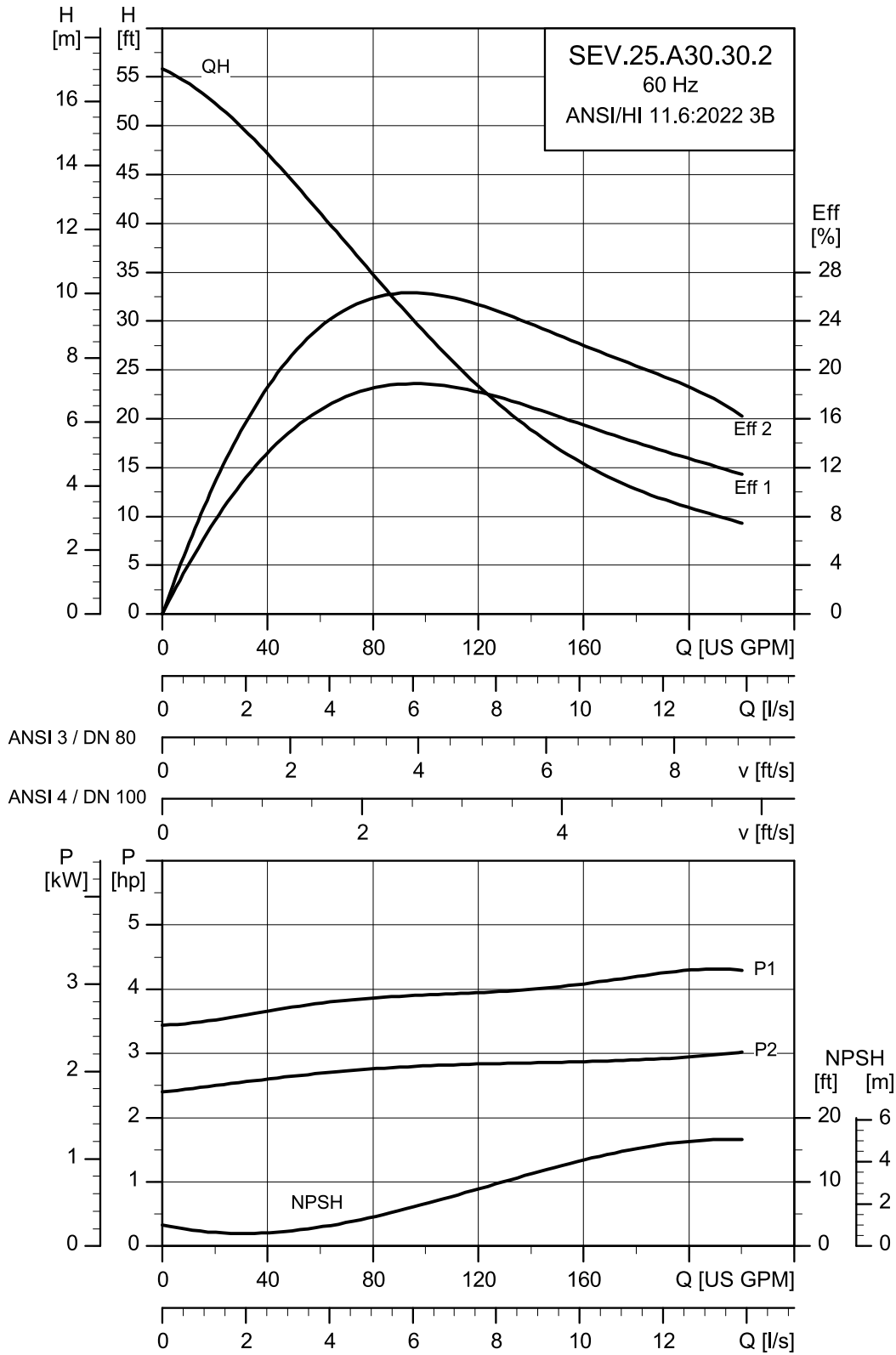

TM086481

Motor data

Pump type	Voltage [V]	P1 [Hp]	P2 [Hp]	No. of poles	RPM	Starting method	I _N [A]	I _{start} [A]	η _{motor} [%]			Cos φ		
									1/2	3/4	1/1	1/2	3/4	1/1
SEV.25.A30.30.A.EX.2.60R	230	4.105	3	2	3.472	Direct-on-line (DOL)	8.7	50	80.5	82.6	82.3	0.83	0.88	0.9
SEV.25.A30.30.A.EX.2.60H	460	4.105	3	2	3.510	Direct-on-line (DOL)	5	34.5	78.4	82.4	83.7	0.7	0.8	0.85

Pump data

Pump type	Impeller diameter [mm]	Moment of inertia (impeller) [kgm ²]	Outlet flange pressure (according to EN 1092-2)	Max. installation depth	Moment of inertia (motor) [kgm ²]	Breakdown torque M _{max} [Nm]
SEV.25.A30.30.A.EX.2.60R	128.3	0.00303	PN 10	12	0.00190	14.6
SEV.25.A30.30.A.EX.2.60H	128.3	0.00303	PN 10	12	0.00190	21.8

SEV.25.A30.40.2.6

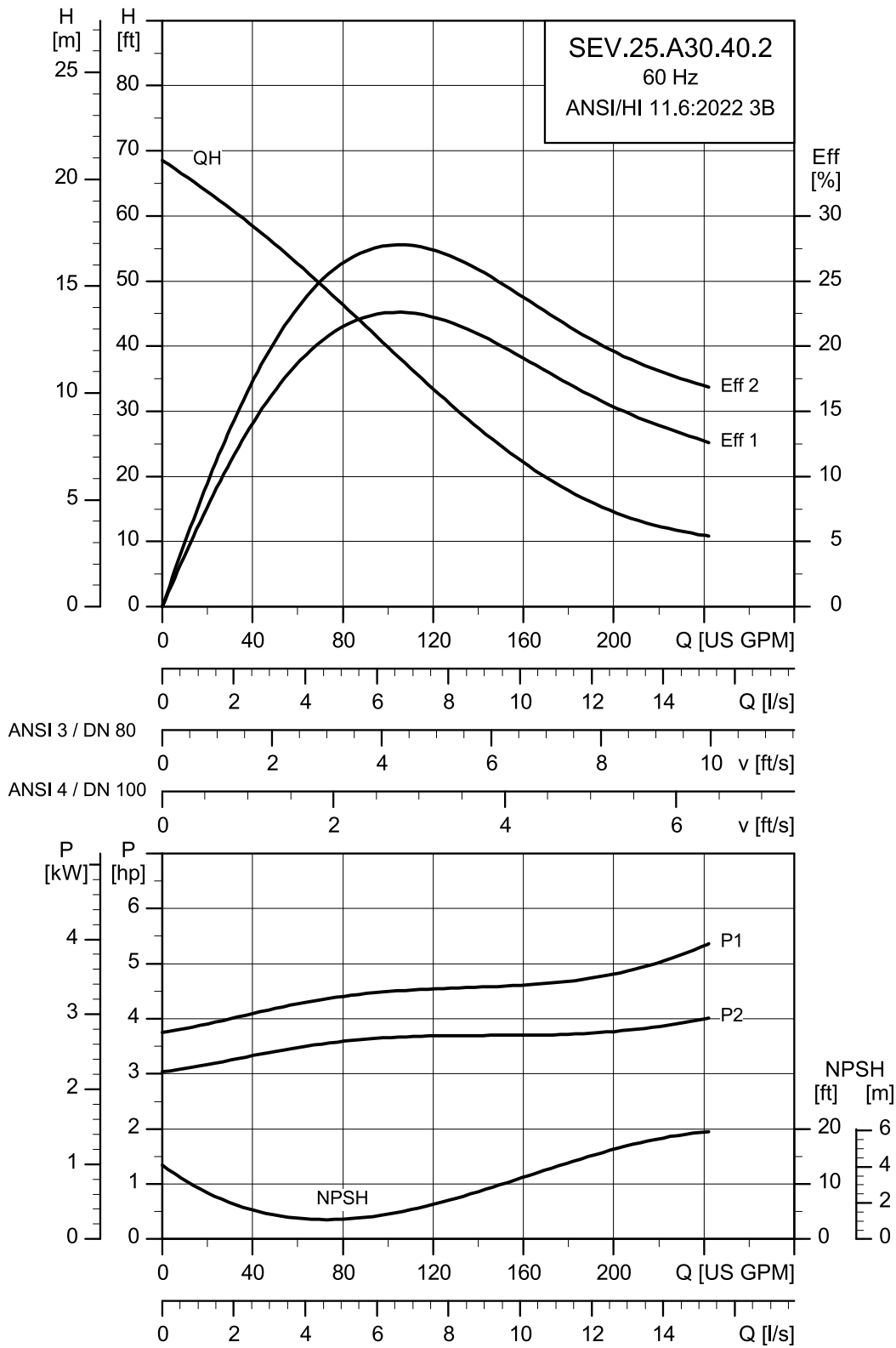

TM086482

Motor data

Pump type	Voltage [V]	P1 [Hp]	P2 [Hp]	No. of poles	RPM	Starting method	I _N [A]	I _{start} [A]	η _{motor} [%]			Cos φ		
									1/2	3/4	1/1	1/2	3/4	1/1
SEV.25.A30.40.A.EX.2.60R	230	4.937	4	2	3.463	Direct-on-line (DOL)	10.14	66	81.2	82.9	82.1	0.85	0.89	0.91
SEV.25.A30.40.A.EX.2.60H	460	4.937	4	2	3.506	Direct-on-line (DOL)	5.07	46	79.9	83.4	84.3	0.77	0.85	0.88

Pump data

Pump type	Impeller diameter [mm]	Moment of inertia (impeller) [kgm ²]	Outlet flange pressure (according to EN 1092-2)	Max. installation depth	Moment of inertia (motor) [kgm ²]	Breakdown torque M _{max} [Nm]
SEV.25.A30.40.A.EX.2.60R	129	0.00346	PN 10	12	0.00260	16.4
SEV.25.A30.40.A.EX.2.60H	129	0.00346	PN 10	12	0.00260	23.4

SEV.25.A30.55.2.6

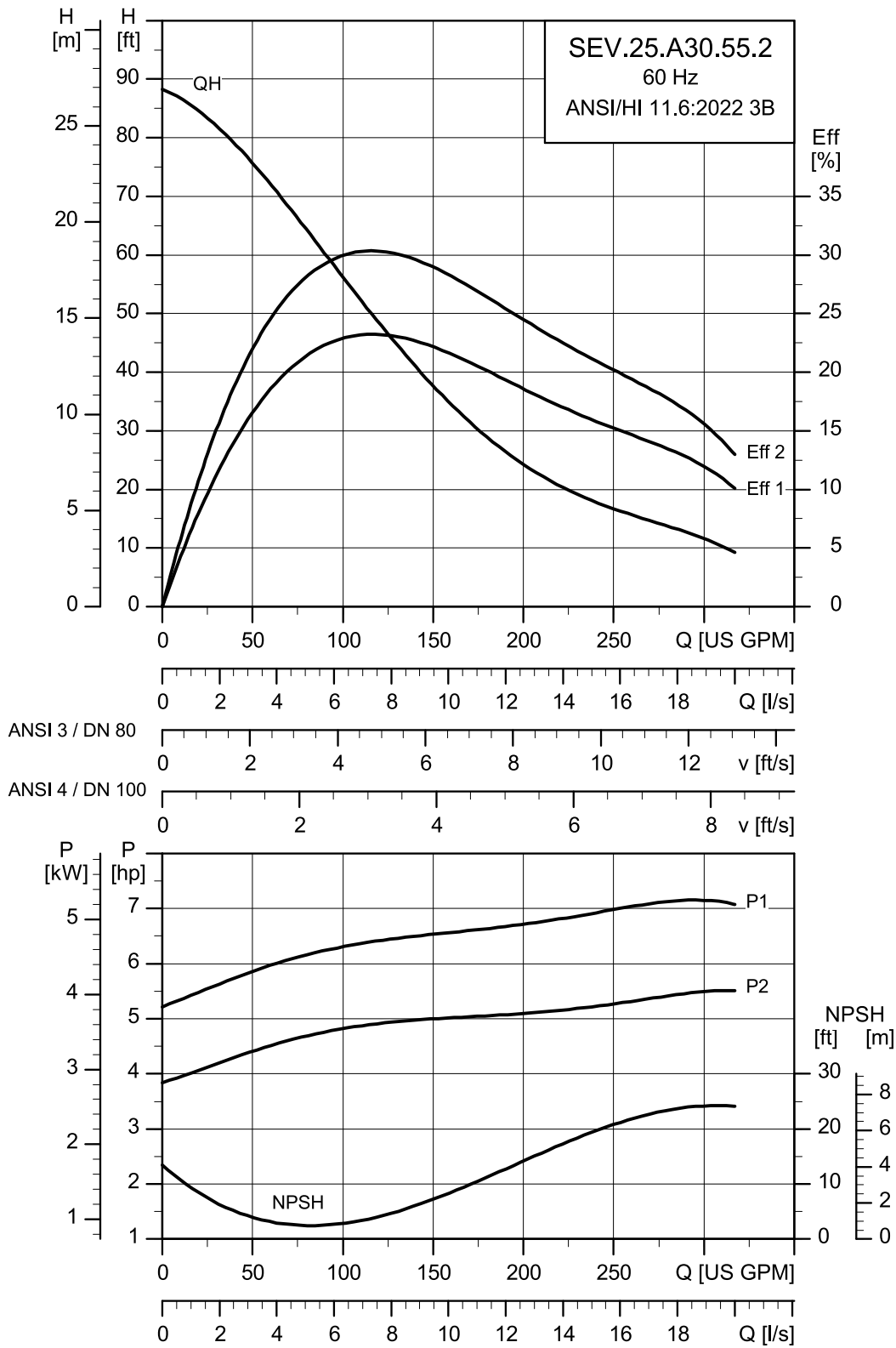

TM086483

Motor data

Pump type	Voltage [V]	P1 [Hp]	P2 [Hp]	No. of poles	RPM	Starting method	I _N [A]	I _{start} [A]	η _{motor} [%]			Cos φ		
									1/2	3/4	1/1	1/2	3/4	1/1
SEV.25.A30.55.A.EX.2.61R	230	6.882	5.5	2	3.485	Star-delta (YD)	13.05	93.5	84.5	86	85.6	0.82	0.88	0.9
	460								6.7	63.5	83.5	86.3	87.1	0.71

Pump data

Pump type	Impeller diameter [mm]	Moment of inertia (impeller) [kgm ²]	Outlet flange pressure (according to EN 1092-2)	Max. installation depth	Moment of inertia (motor) [kgm ²]	Breakdown torque M _{max} [Nm]
SEV.25.A30.55.A.EX.2.61R	144	0.00552	PN 10	12	0.00540	31 45.5

SEV.30.A30.15.4.6

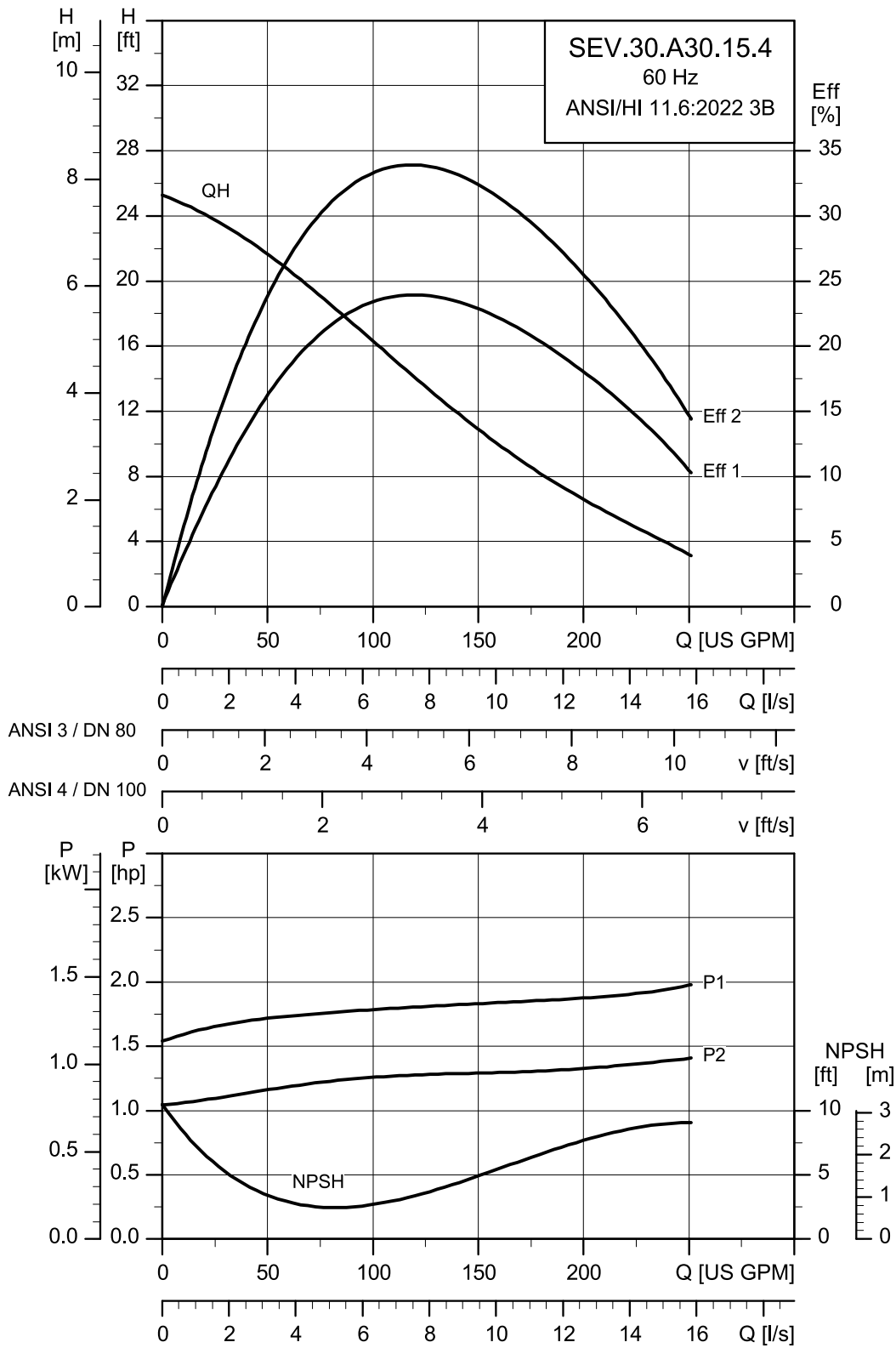

TM086486

Motor data

Pump type	Voltage [V]	P1 [Hp]	P2 [Hp]	No. of poles	RPM	Starting method	I _N [A]	I _{start} [A]	η _{motor} [%]			Cos φ		
									1/2	3/4	1/1	1/2	3/4	1/1
SEV.30.A30.15.A.EX.4.60R	230	2.064	1.5	4	1.714	Direct-on-line (DOL)	4.28	19.8	76.8	78.5	77.5	0.68	0.78	0.83
SEV.30.A30.15.A.EX.4.60H	460	2.064	1.5	4	1.742	Direct-on-line (DOL)	3.8	13.4	72.6	77.4	79	0.52	0.65	0.74

Pump data

Pump type	Impeller diameter [mm]	Moment of inertia (impeller) [kgm ²]	Outlet flange pressure (according to EN 1092-2)	Max. installation depth	Moment of inertia (motor) [kgm ²]	Breakdown torque M _{max} [Nm]
SEV.30.A30.15.A.EX.4.60R	155	0.00964	PN 10	12	0.00260	14
SEV.30.A30.15.A.EX.4.60H	155	0.00964	PN 10	12	0.00260	19

SEV.30.A30.18.4.6

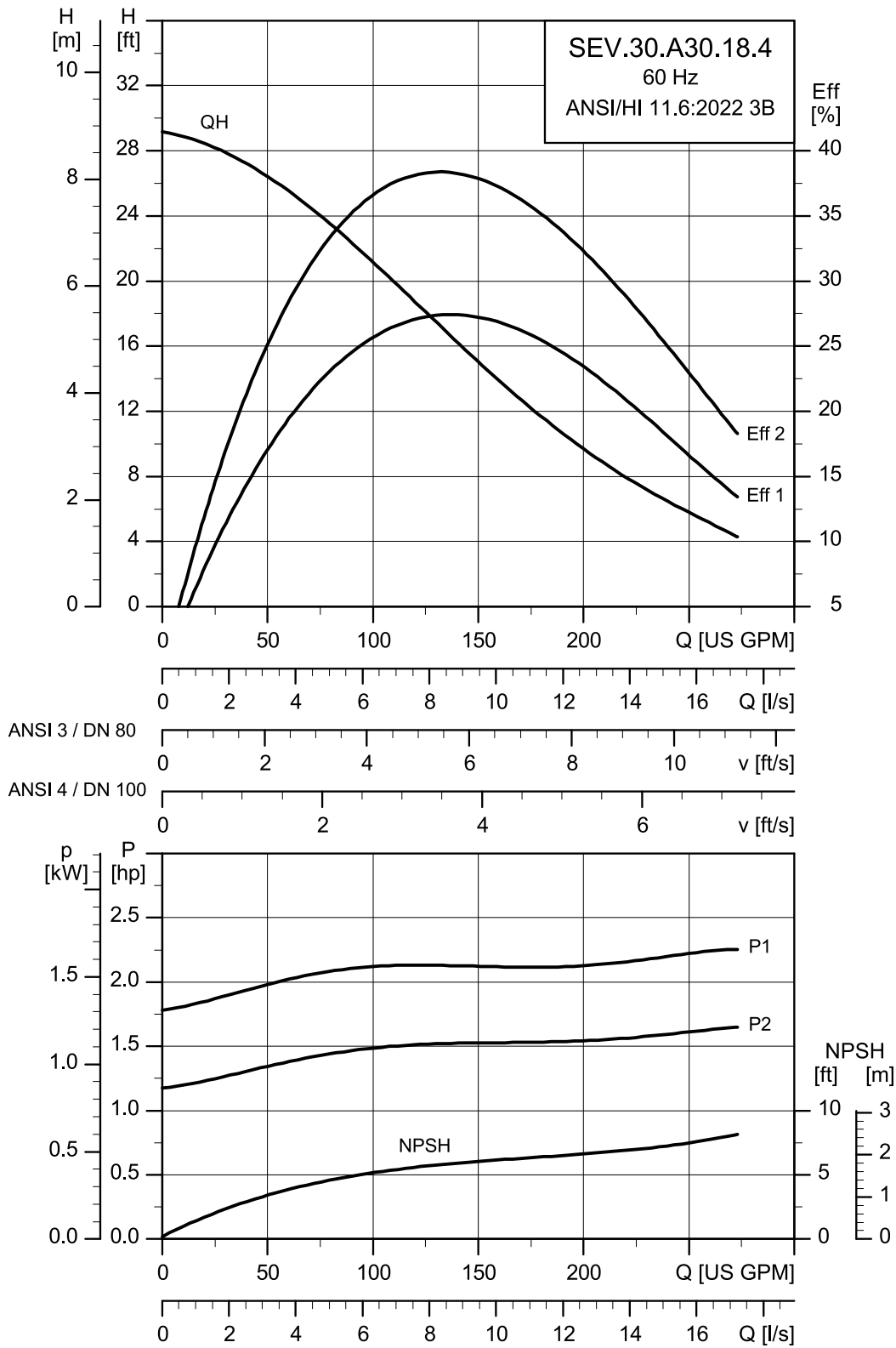

TM086488

Motor data

Pump type	Voltage [V]	P1 [Hp]	P2 [Hp]	No. of poles	RPM	Starting method	I _N [A]	I _{start} [A]	η _{motor} [%]			Cos φ		
									1/2	3/4	1/1	1/2	3/4	1/1
SEV.30.A30.18.A.EX.4.60R	230	2.381	1.8	4	1.724	Direct-on-line (DOL)	5.128	29.5	75.9	78.8	78.4	0.67	0.76	0.81
SEV.30.A30.18.A.EX.4.60H	460	2.381	1.8	4	1.749	Direct-on-line (DOL)	4.2	20.2	72.5	77.7	79	0.53	0.65	0.73

Pump data

Pump type	Impeller diameter [mm]	Moment of inertia (impeller) [kgm ²]	Outlet flange pressure (according to EN 1092-2)	Max. installation depth	Moment of inertia (motor) [kgm ²]	Breakdown torque M _{max} [Nm]
SEV.30.A30.18.A.EX.4.60R	163	0.01113	PN 10	12	0.00330	19.4
SEV.30.A30.18.A.EX.4.60H	163	0.01113	PN 10	12	0.00330	26.5

SEV.30.A30.20.4.6

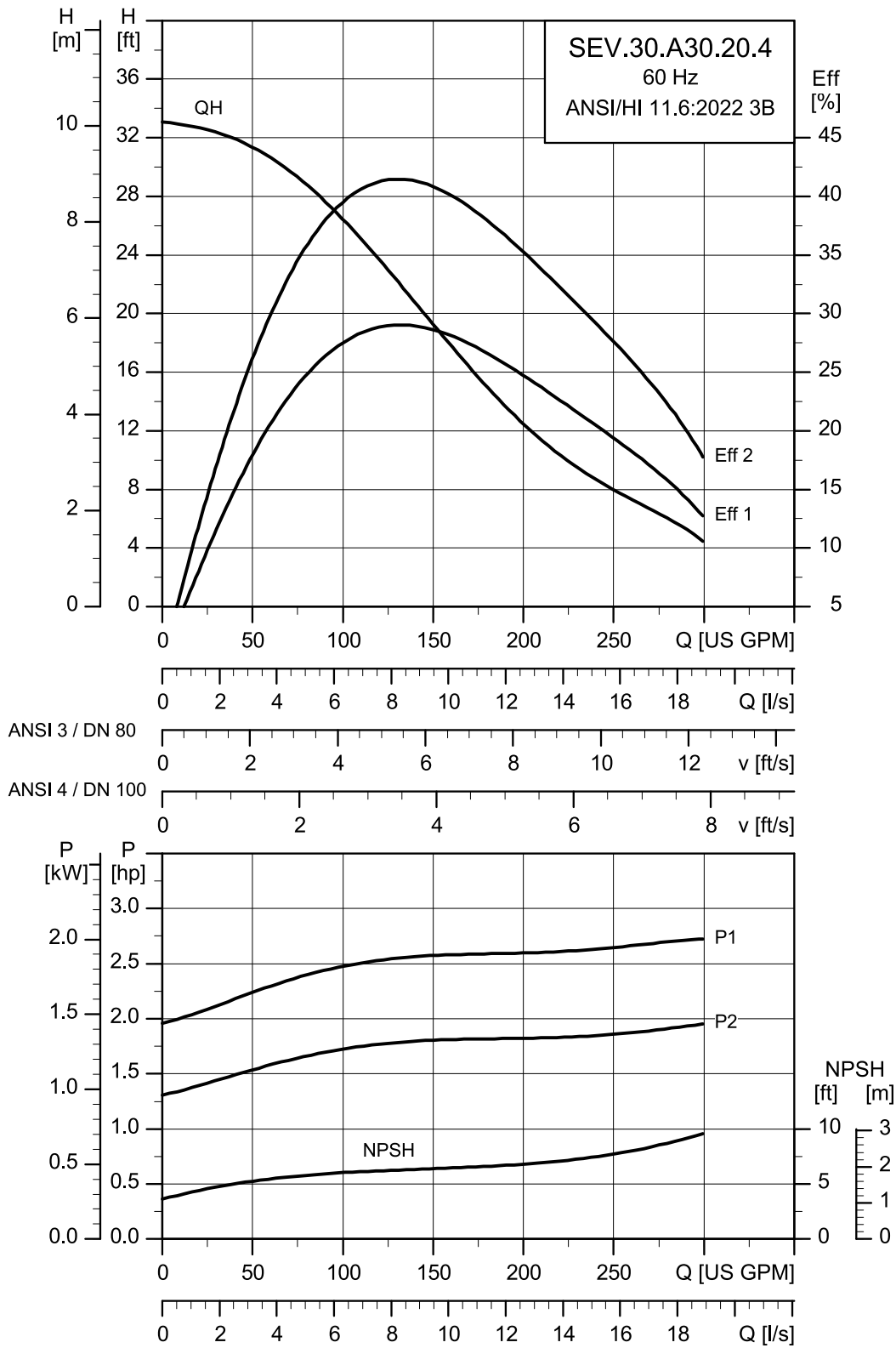

TM086489

Motor data

Pump type	Voltage [V]	P1 [Hp]	P2 [Hp]	No. of poles	RPM	Starting method	I _N [A]	I _{start} [A]	η _{motor} [%]			Cos φ		
									1/2	3/4	1/1	1/2	3/4	1/1
SEV.30.A30.20.A.EX.4.60R	230	2.806	2	4	1.703	Direct-on-line (DOL)	7.3	29.5	77.5	79	77.1	0.71	0.79	0.83
SEV.30.A30.20.A.EX.4.60H	460	2.806	2	4	1.739	Direct-on-line (DOL)	4.2	20.2	74.7	78.9	80	0.57	0.69	0.77

Pump data

Pump type	Impeller diameter [mm]	Moment of inertia (impeller) [kgm ²]	Outlet flange pressure (according to EN 1092-2)	Max. installation depth	Moment of inertia (motor) [kgm ²]	Breakdown torque M _{max} [Nm]
SEV.30.A30.20.A.EX.4.60R	170	0.01250	PN 10	12	0.00330	19.4
SEV.30.A30.20.A.EX.4.60H	170	0.01250	PN 10	12	0.00330	26.5

SEV.30.A30.30.4.6

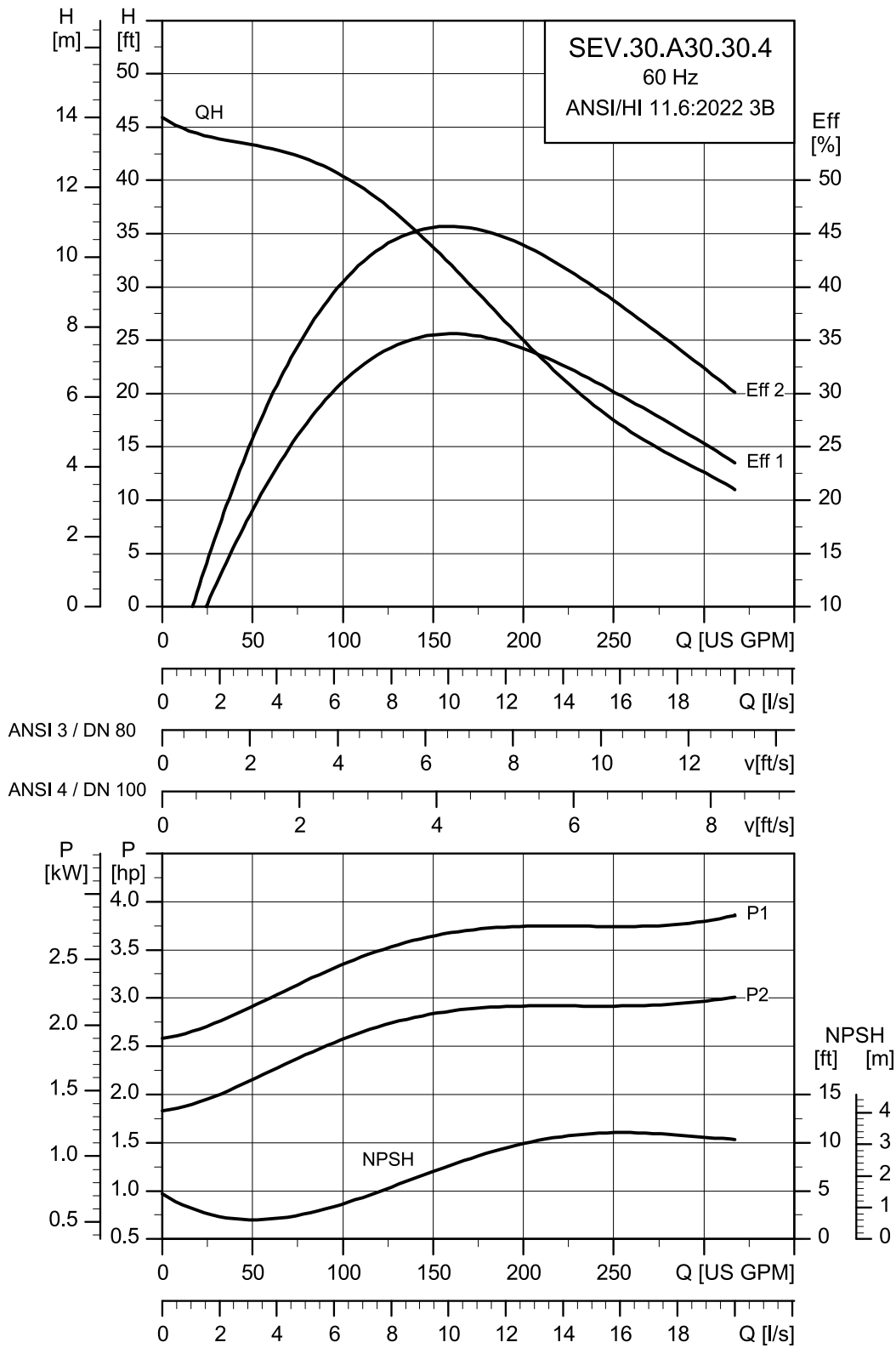

TM086490

Motor data

Pump type	Voltage [V]	P1 [Hp]	P2 [Hp]	No. of poles	RPM	Starting method	I _N [A]	I _{start} [A]	η _{motor} [%]			Cos φ		
									1/2	3/4	1/1	1/2	3/4	1/1
SEV.30.A30.30.A.EX.4.60R	230	3.772	3	4	1.717	Direct-on-line (DOL)	8.19	51.5	80.6	82.1	81	0.69	0.78	0.83
SEV.30.A30.30.A.EX.4.60H	460	3.772	3	4	1.743	Direct-on-line (DOL)	5.9	35.5	77.2	81.1	82.4	0.52	0.65	0.74

Pump data

Pump type	Impeller diameter [mm]	Moment of inertia (impeller) [kgm ²]	Outlet flange pressure (according to EN 1092-2)	Max. installation depth	Moment of inertia (motor) [kgm ²]	Breakdown torque M _{max} [Nm]
SEV.30.A30.30.A.EX.4.60R	188	0.01639	PN 10	12	0.00440	33.5
SEV.30.A30.30.A.EX.4.60H	188	0.01639	PN 10	12	0.00440	45.5

SEV.30.A30.55.4.6

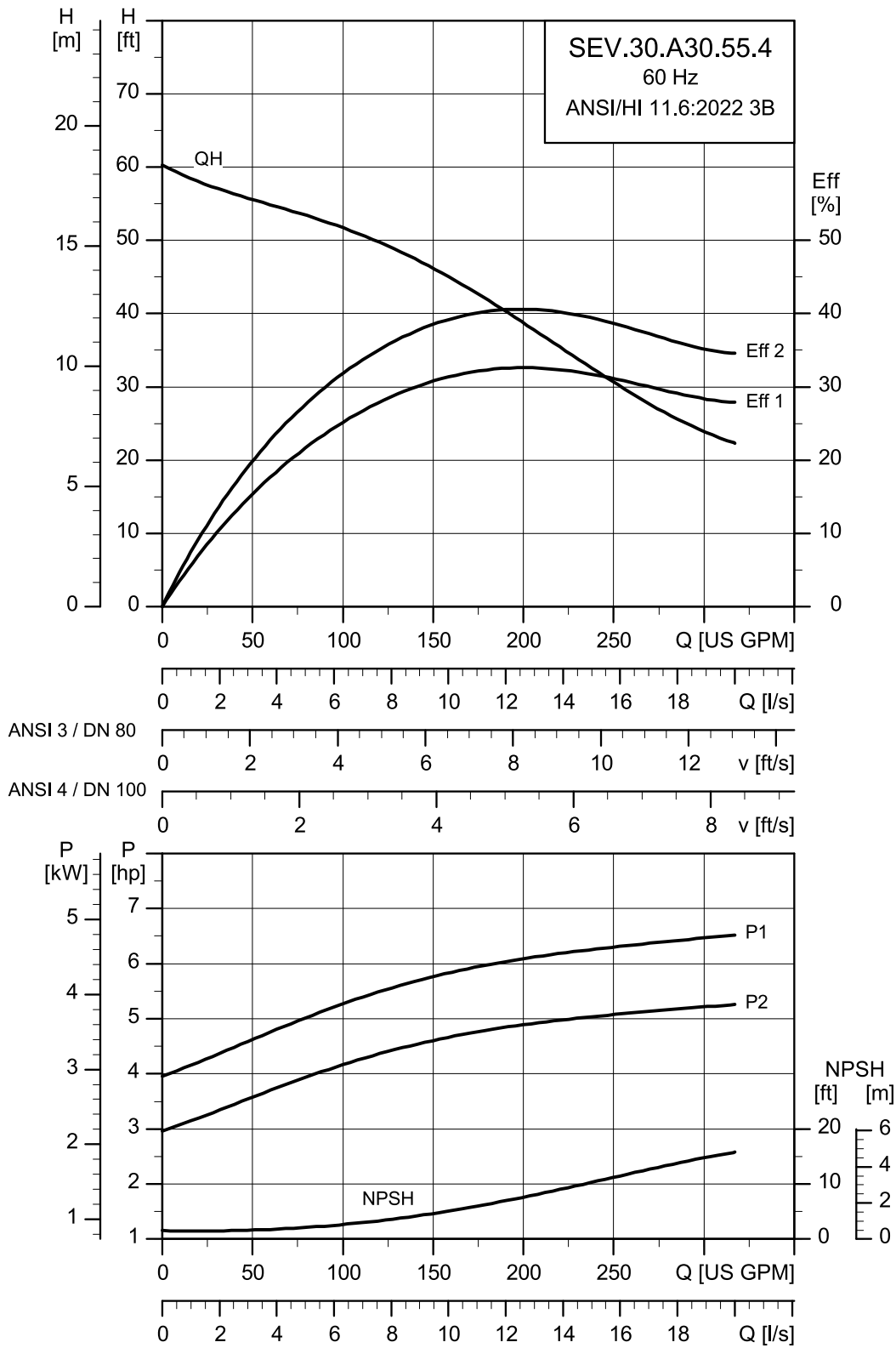

TM086491

Motor data

Pump type	Voltage [V]	P1 [Hp]	P2 [Hp]	No. of poles	RPM	Starting method	I _N [A]	I _{start} [A]	η _{motor} [%]			Cos φ		
									1/2	3/4	1/1	1/2	3/4	1/1
SEV.30.A30.55.A.EX.4.61R	230	6.646	5.5	4	1.741	Star-delta (YD)	14.04	84	86.8	86.9	85.5	0.72	0.8	0.83
	460								7.26	58.5	85.7	87.6	87.7	0.59

Pump data

Pump type	Impeller diameter [mm]	Moment of inertia (impeller) [kgm ²]	Outlet flange pressure (according to EN 1092-2)	Max. installation depth	Moment of inertia (motor) [kgm ²]	Breakdown torque M _{max} [Nm]
SEV.30.A30.55.A.EX.4.61R	208	0.03780	PN 10	12	0.01280	52
						71

SEV.30.A30.80.2.6

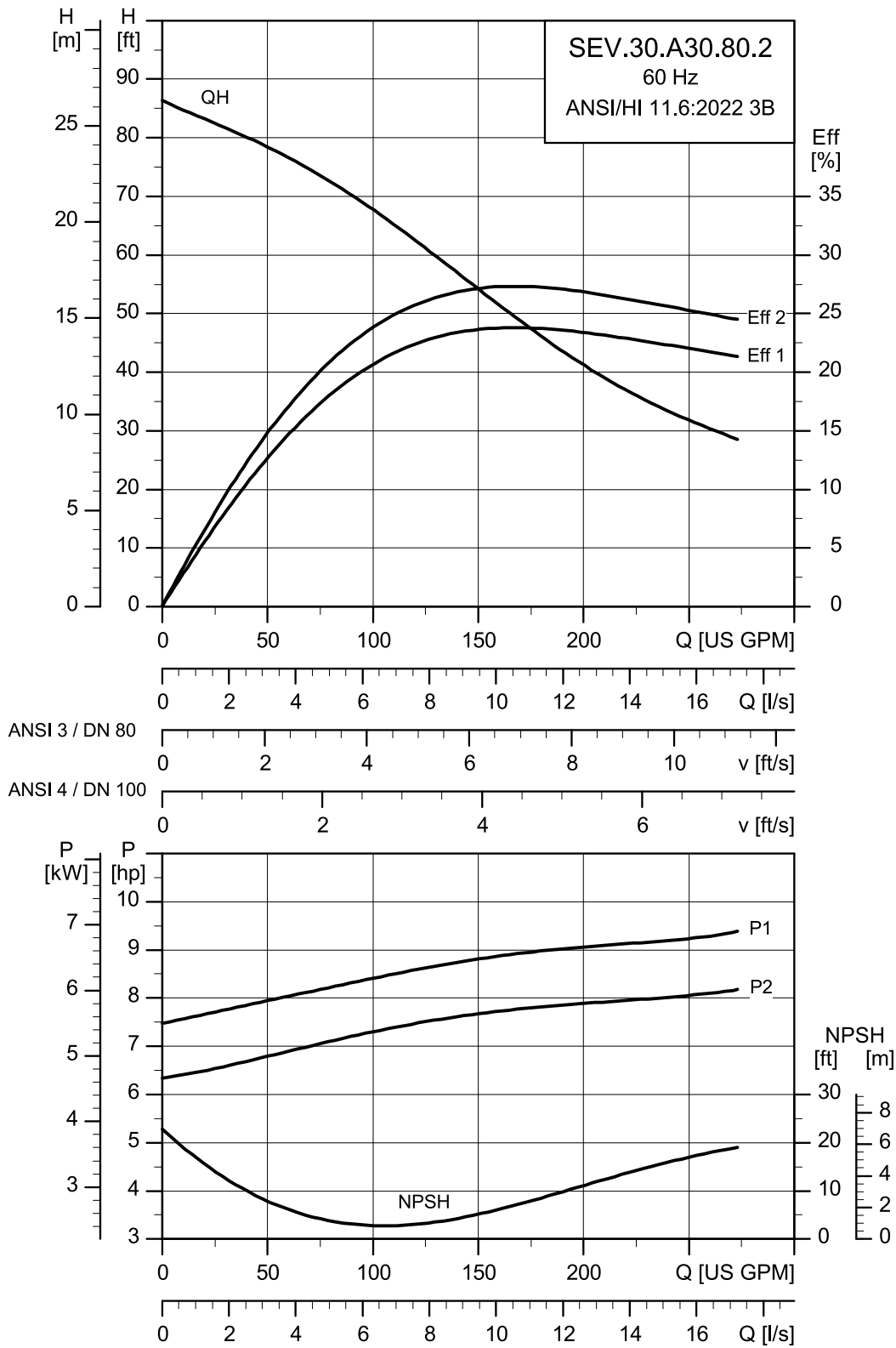

TM086492

Motor data

Pump type	Voltage [V]	P1 [Hp]	P2 [Hp]	No. of poles	RPM	Starting method	I _N [A]	I _{start} [A]	η _{motor} [%]			Cos φ		
									1/2	3/4	1/1	1/2	3/4	1/1
SEV.30.A30.80.A.EX.2.61R	230	9.22	8	2	3.510	Star-delta (YD)	19.3	214	85.8	87.9	88.2	0.76	0.85	0.88
	460								10.9	146	83.5	86.9	88.2	0.56

Pump data

Pump type	Impeller diameter [mm]	Moment of inertia (impeller) [kgm ²]	Outlet flange pressure (according to EN 1092-2)	Max. installation depth	Moment of inertia (motor) [kgm ²]	Breakdown torque M _{max} [Nm]
SEV.30.A30.80.A.EX.2.61R	151	0.00718	PN 10	12	0.00800	74.5
						104

SEV.30.A30.100.2.6

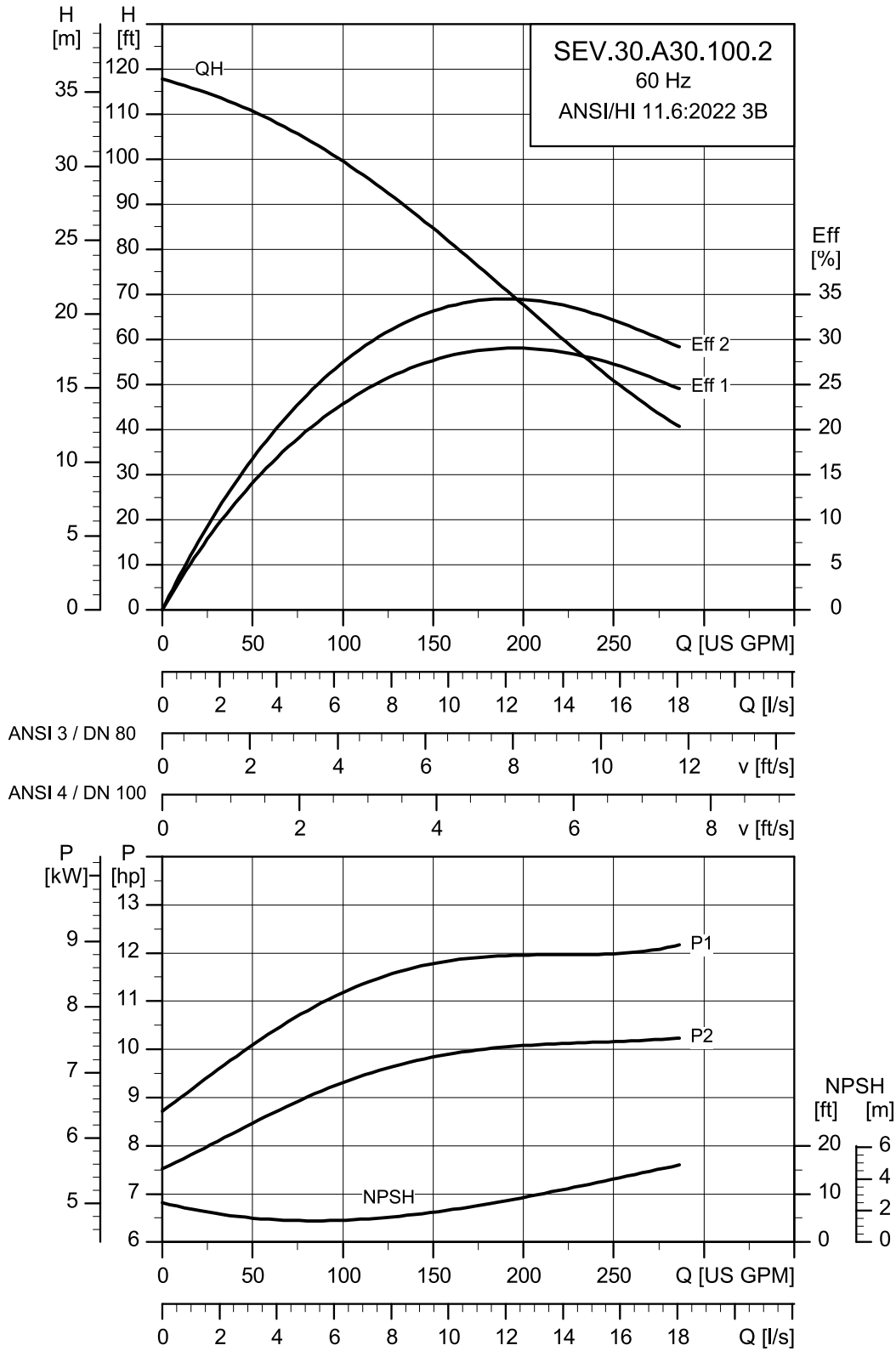

TM086484

Motor data

Pump type	Voltage [V]	P1 [Hp]	P2 [Hp]	No. of poles	RPM	Starting method	I _N [A]	I _{start} [A]	η _{motor} [%]			Cos φ		
									1/2	3/4	1/1	1/2	3/4	1/1
SEV.30.A30.100.A.EX.2.61R	230	11.639	10	2	3.484	Star-delta (YD)	23.72	214	87.2	88.2	87.7	0.81	0.88	0.9
	460								12.8	146	85.6	88	88.6	0.64

Pump data

Pump type	Impeller diameter [mm]	Moment of inertia (impeller) [kgm ²]	Outlet flange pressure (according to EN 1092-2)	Max. installation depth	Moment of inertia (motor) [kgm ²]	Breakdown torque M _{max} [Nm]
SEV.30.A30.100.A.EX.2.61R	165	0.00997	PN 10	12	0.00800	74.5
						104

SEV.30.A30.125.2.6

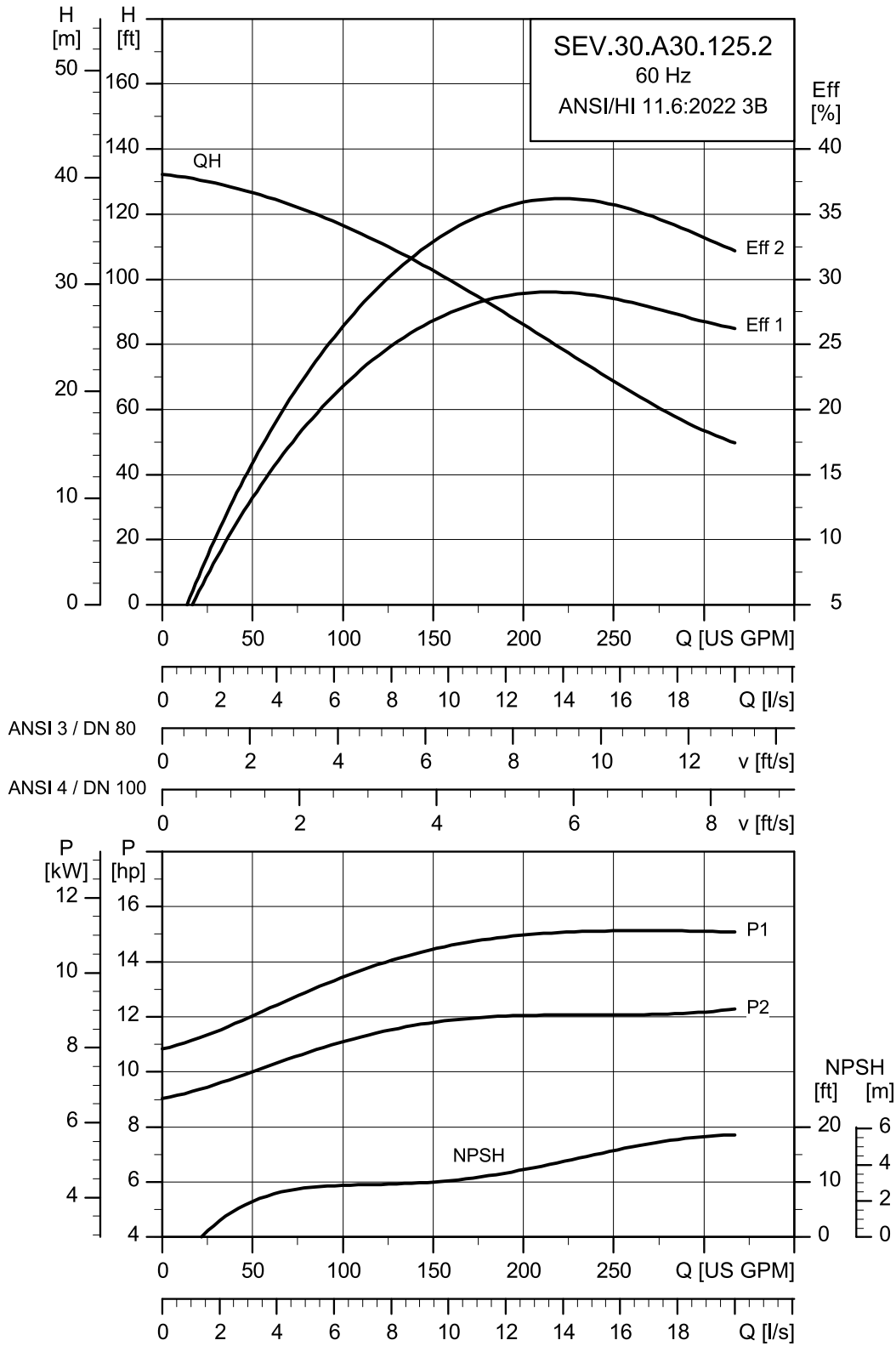

TM086485

Motor data

Pump type	Voltage [V]	P1 [Hp]	P2 [Hp]	No. of poles	RPM	Starting method	I _N [A]	I _{start} [A]	η _{motor} [%]			Cos φ		
									1/2	3/4	1/1	1/2	3/4	1/1
SEV.30.A30.125.A.EX.2.61R	230	14.796	12.5	2	3.496	Star-delta (YD)	34.73	164	90.1	90.1	88.6	0.65	0.73	0.75
	460								20.5	112	86.4	88.5	88.9	0.43

Pump data

Pump type	Impeller diameter [mm]	Moment of inertia (impeller) [kgm ²]	Outlet flange pressure (according to EN 1092-2)	Max. installation depth	Moment of inertia (motor) [kgm ²]	Breakdown torque M _{max} [Nm]
SEV.30.A30.125.A.EX.2.61R	173	0.01235	PN 10	12	0.01580	49.5
						71.5

SEV.30.A30.150.2.6

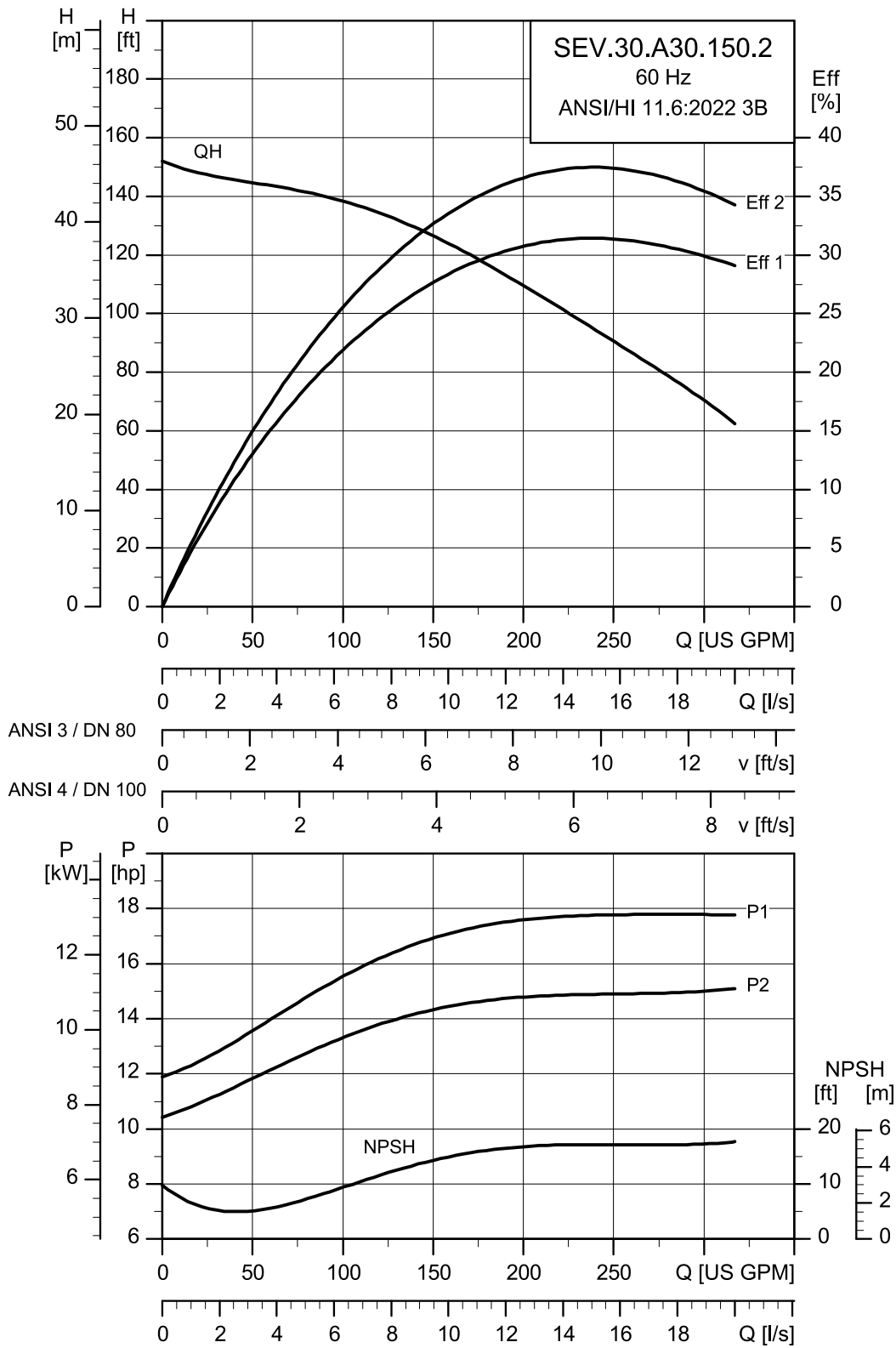

TM086487

Motor data

Pump type	Voltage [V]	P1 [Hp]	P2 [Hp]	No. of poles	RPM	Starting method	I _N [A]	I _{start} [A]	η _{motor} [%]			Cos φ		
									1/2	3/4	1/1	1/2	3/4	1/1
SEV.30.A30.150.A.EX.2.61R	230	16.787	15	2	3.503	Star-delta (YD)	43.78	206	88.8	89.5	88.5	0.54	0.66	0.71
	460								29.7	144	81.8	85.3	86.5	0.33

Pump data

Pump type	Impeller diameter [mm]	Moment of inertia (impeller) [kgm ²]	Outlet flange pressure (according to EN 1092-2)	Max. installation depth	Moment of inertia (motor) [kgm ²]	Breakdown torque M _{max} [Nm]
SEV.30.A30.150.A.EX.2.61R	181	0.01469	PN 10	12	0.01580	65 104

SEV.30.A40.15.4.6

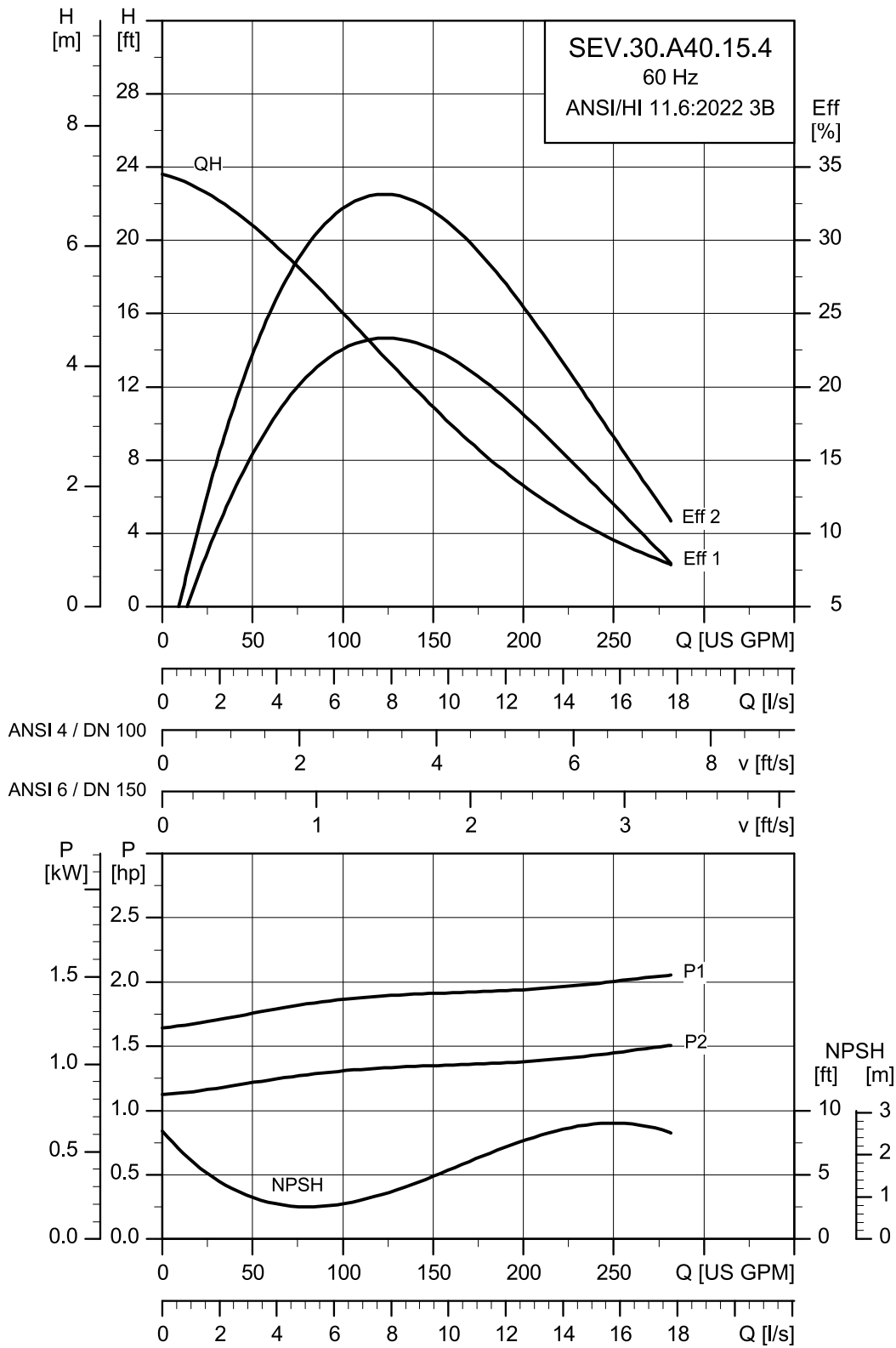

TM086495

Motor data

Pump type	Voltage [V]	P1 [Hp]	P2 [Hp]	No. of poles	RPM	Starting method	I _N [A]	I _{start} [A]	η _{motor} [%]			Cos φ		
									1/2	3/4	1/1	1/2	3/4	1/1
SEV.30.A40.15.A.EX.4.60R	230	2.011	1.5	4	1.714	Direct-on-line (DOL)	4.28	19.8	76.8	78.5	77.5	0.68	0.78	0.83
SEV.30.A40.15.A.EX.4.60H	460	2.011	1.5	4	1.742	Direct-on-line (DOL)	3.8	13.4	72.6	77.4	79	0.52	0.65	0.74

Pump data

Pump type	Impeller diameter [mm]	Moment of inertia (impeller) [kgm ²]	Outlet flange pressure (according to EN 1092-2)	Max. installation depth	Moment of inertia (motor) [kgm ²]	Breakdown torque M _{max} [Nm]
SEV.30.A40.15.A.EX.4.60R	155	0.00964	PN 10	12	0.00260	14
SEV.30.A40.15.A.EX.4.60H	155	0.00964	PN 10	12	0.00260	19

SEV.30.A40.18.4.6

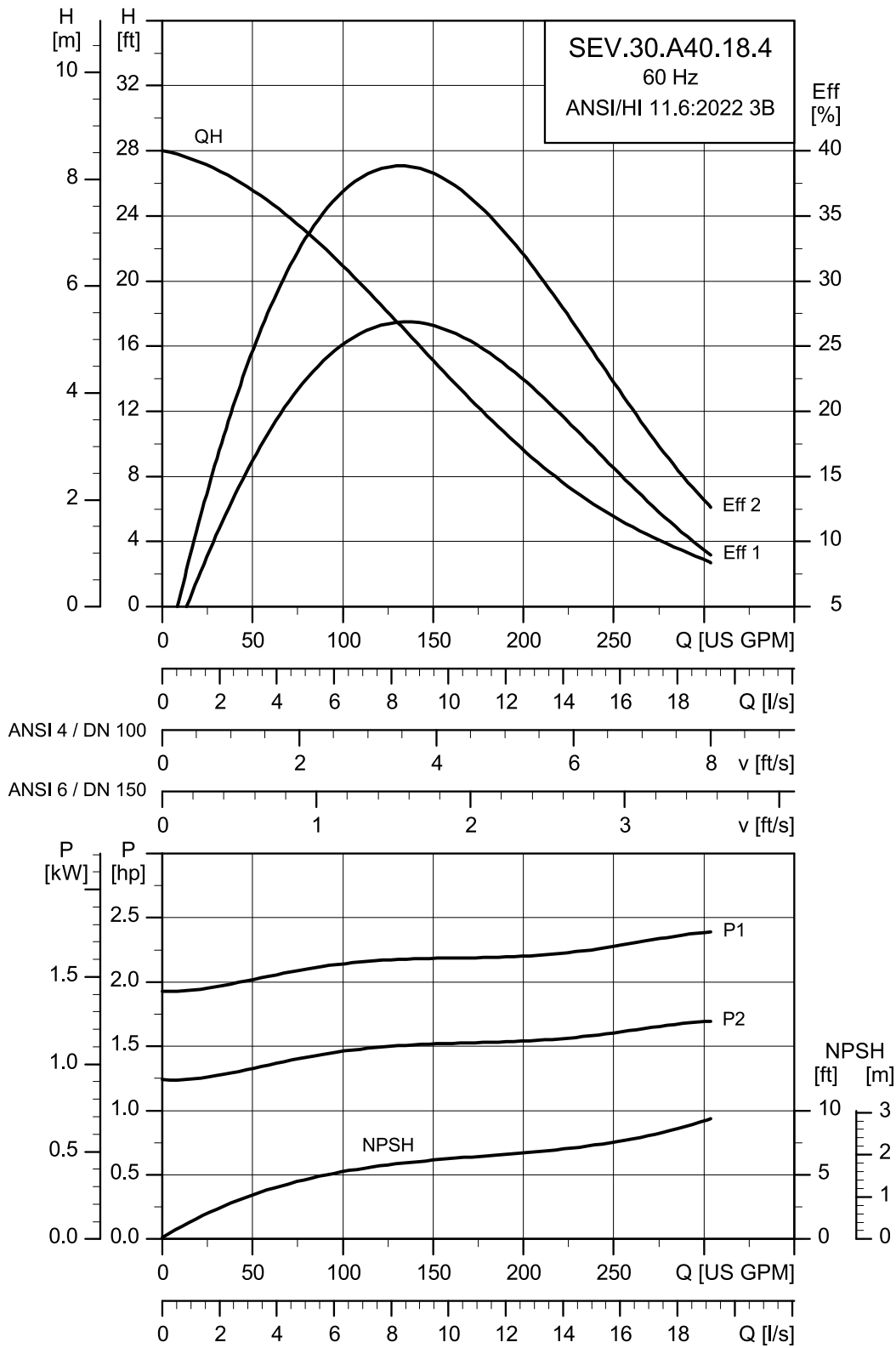

TM086497

Motor data

Pump type	Voltage [V]	P1 [Hp]	P2 [Hp]	No. of poles	RPM	Starting method	I _N [A]	I _{start} [A]	η _{motor} [%]			Cos φ		
									1/2	3/4	1/1	1/2	3/4	1/1
SEV.30.A40.18.A.EX.4.60R	230	2.457	1.8	4	1.724	Direct-on-line (DOL)	5.128	29.5	75.9	78.8	78.4	0.67	0.76	0.81
SEV.30.A40.18.A.EX.4.60H	460	2.457	1.8	4	1.749	Direct-on-line (DOL)	4.2	20.2	72.5	77.7	79	0.53	0.65	0.73

Pump data

Pump type	Impeller diameter [mm]	Moment of inertia (impeller) [kgm ²]	Outlet flange pressure (according to EN 1092-2)	Max. installation depth	Moment of inertia (motor) [kgm ²]	Breakdown torque M _{max} [Nm]
SEV.30.A40.18.A.EX.4.60R	163	0.01113	PN 10	12	0.00330	19.4
SEV.30.A40.18.A.EX.4.60H	163	0.01113	PN 10	12	0.00330	26.5

SEV.30.A40.20.4.6

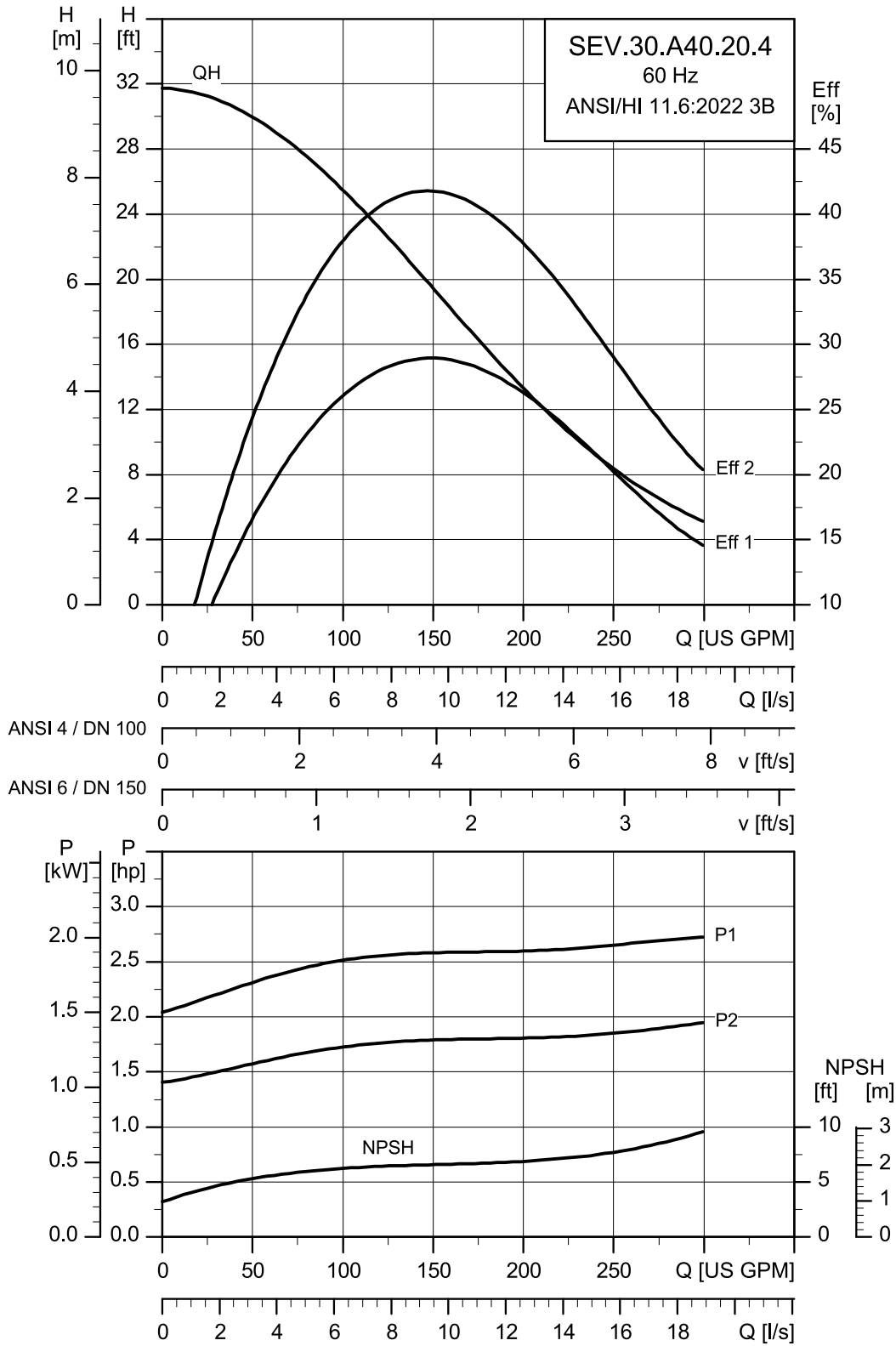

TM086498

Motor data

Pump type	Voltage [V]	P1 [Hp]	P2 [Hp]	No. of poles	RPM	Starting method	I _N [A]	I _{start} [A]	η _{motor} [%]			Cos φ		
									1/2	3/4	1/1	1/2	3/4	1/1
SEV.30.A40.20.A.EX.4.60R	230	2.814	2	4	1.703	Direct-on-line (DOL)	7.3	29.5	77.5	79	77.1	0.71	0.79	0.83
SEV.30.A40.20.A.EX.4.60H	460	2.814	2	4	1.739	Direct-on-line (DOL)	4.2	20.2	74.7	78.9	80	0.57	0.69	0.77

Pump data

Pump type	Impeller diameter [mm]	Moment of inertia (impeller) [kgm ²]	Outlet flange pressure (according to EN 1092-2)	Max. installation depth	Moment of inertia (motor) [kgm ²]	Breakdown torque M _{max} [Nm]
SEV.30.A40.20.A.EX.4.60R	170	0.01250	PN 10	12	0.00330	19.4
SEV.30.A40.20.A.EX.4.60H	170	0.01250	PN 10	12	0.00330	26.5

SEV.30.A40.30.4.6

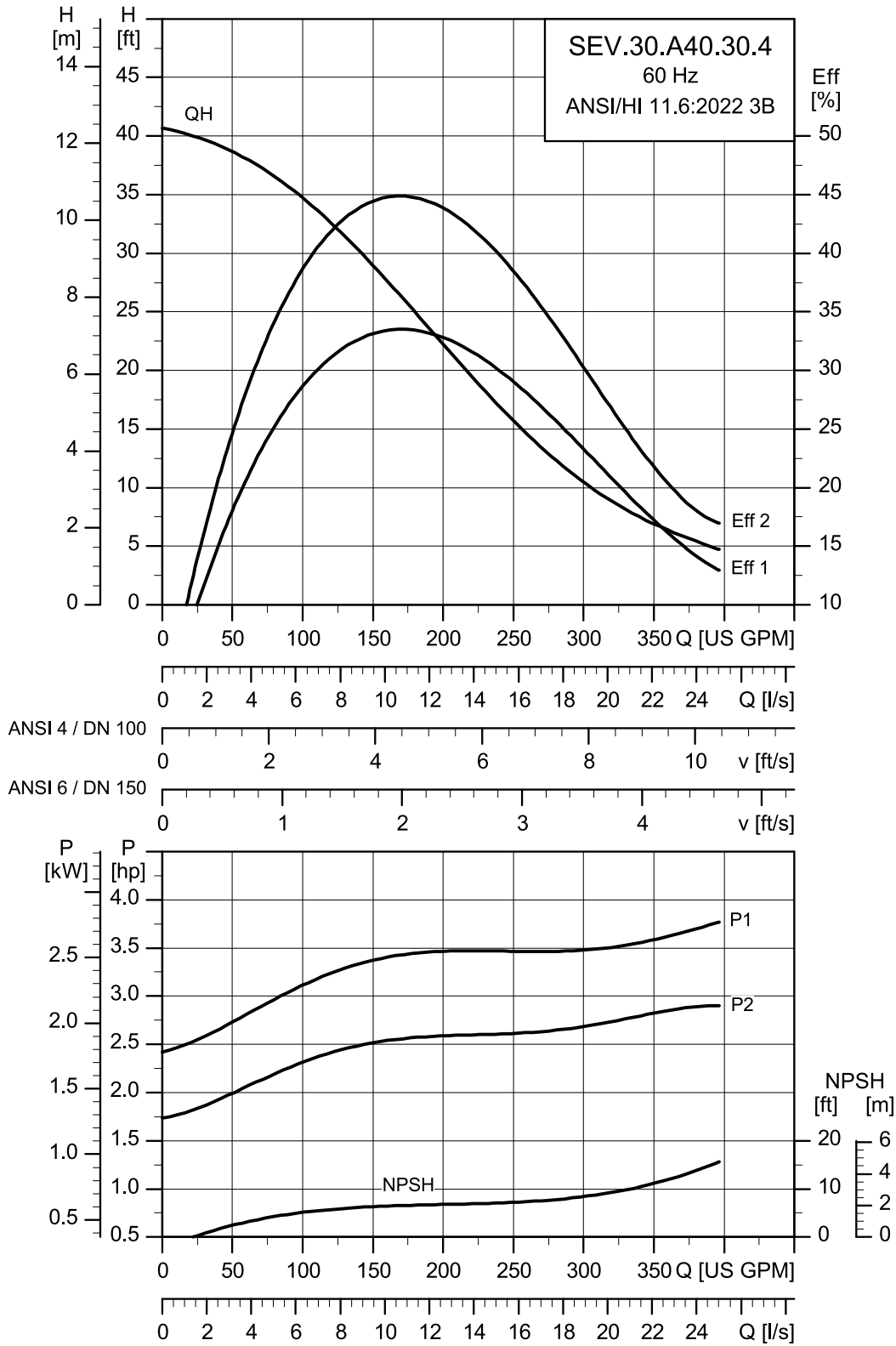

TM086499

Motor data

Pump type	Voltage [V]	P1 [Hp]	P2 [Hp]	No. of poles	RPM	Starting method	I _N [A]	I _{start} [A]	η _{motor} [%]			Cos φ		
									1/2	3/4	1/1	1/2	3/4	1/1
SEV.30.A40.30.A.EX.4.60R	230	3.741	3	4	1.717	Direct-on-line (DOL)	8.19	51.5	80.6	82.1	81	0.69	0.78	0.83
SEV.30.A40.30.A.EX.4.60H	460	3.741	3	4	1.743	Direct-on-line (DOL)	5.9	35.5	77.2	81.1	82.4	0.52	0.65	0.74

Pump data

Pump type	Impeller diameter [mm]	Moment of inertia (impeller) [kgm ²]	Outlet flange pressure (according to EN 1092-2)	Max. installation depth	Moment of inertia (motor) [kgm ²]	Breakdown torque M _{max} [Nm]
SEV.30.A40.30.A.EX.4.60R	184	0.01547	PN 10	12	0.00440	33.5
SEV.30.A40.30.A.EX.4.60H	184	0.01547	PN 10	12	0.00440	45.5

SEV.30.A40.55.4.6

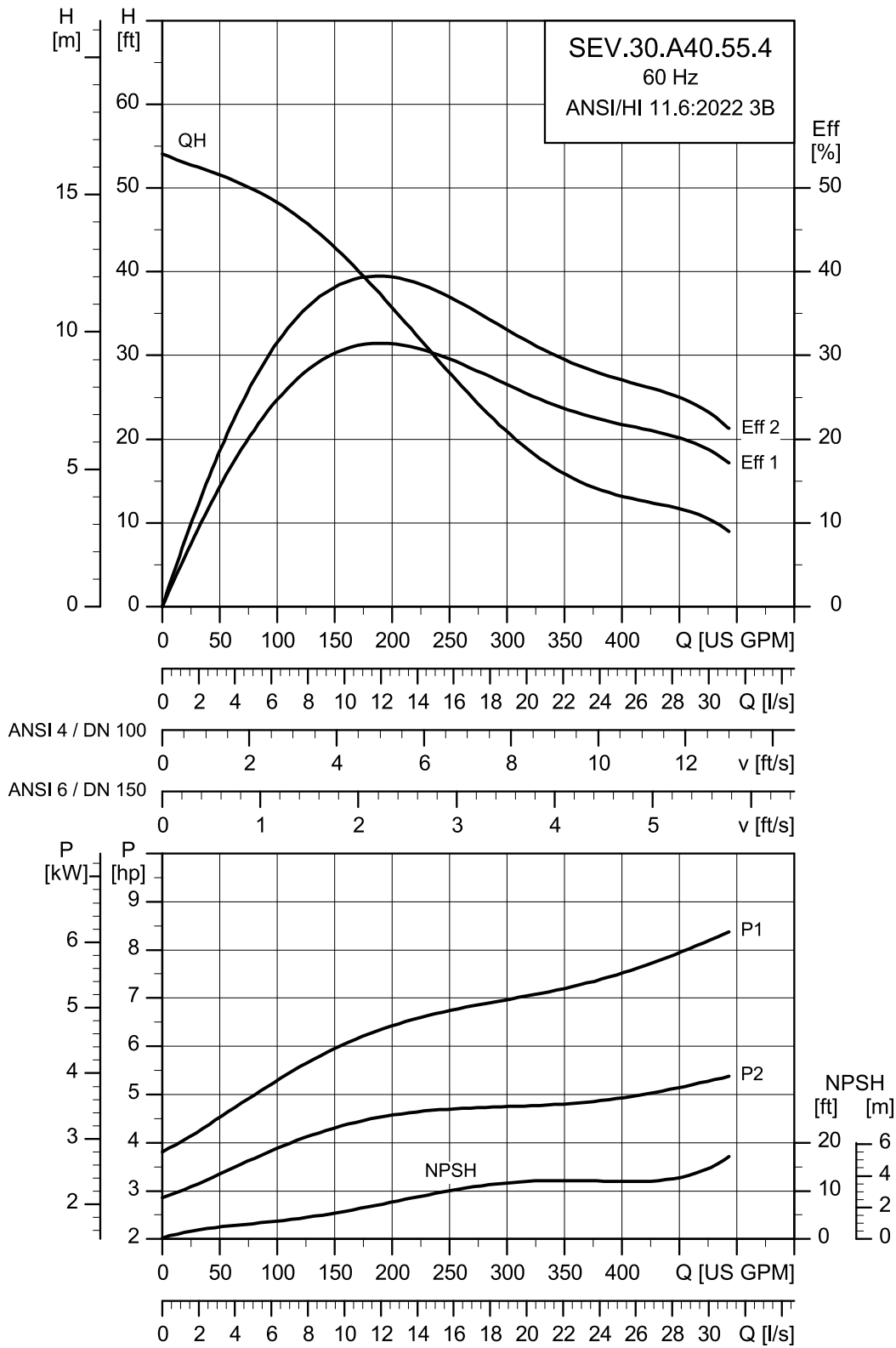

TM086500

Motor data

Pump type	Voltage [V]	P1 [Hp]	P2 [Hp]	No. of poles	RPM	Starting method	I _N [A]	I _{start} [A]	η _{motor} [%]			Cos φ		
									1/2	3/4	1/1	1/2	3/4	1/1
SEV.30.A40.55.A.EX.4.61R	230	6.646	5.5	4	1.741	Star-delta (YD)	14.04	84	86.8	86.9	85.5	0.72	0.8	0.83
	460								7.26	58.5	85.7	87.6	87.7	0.59

Pump data

Pump type	Impeller diameter [mm]	Moment of inertia (impeller) [kgm ²]	Outlet flange pressure (according to EN 1092-2)	Max. installation depth	Moment of inertia (motor) [kgm ²]	Breakdown torque M _{max} [Nm]
SEV.30.A40.55.A.EX.4.61R	203	0.03702	PN 10	12	0.01280	52
						71

SEV.30.A40.80.2.6

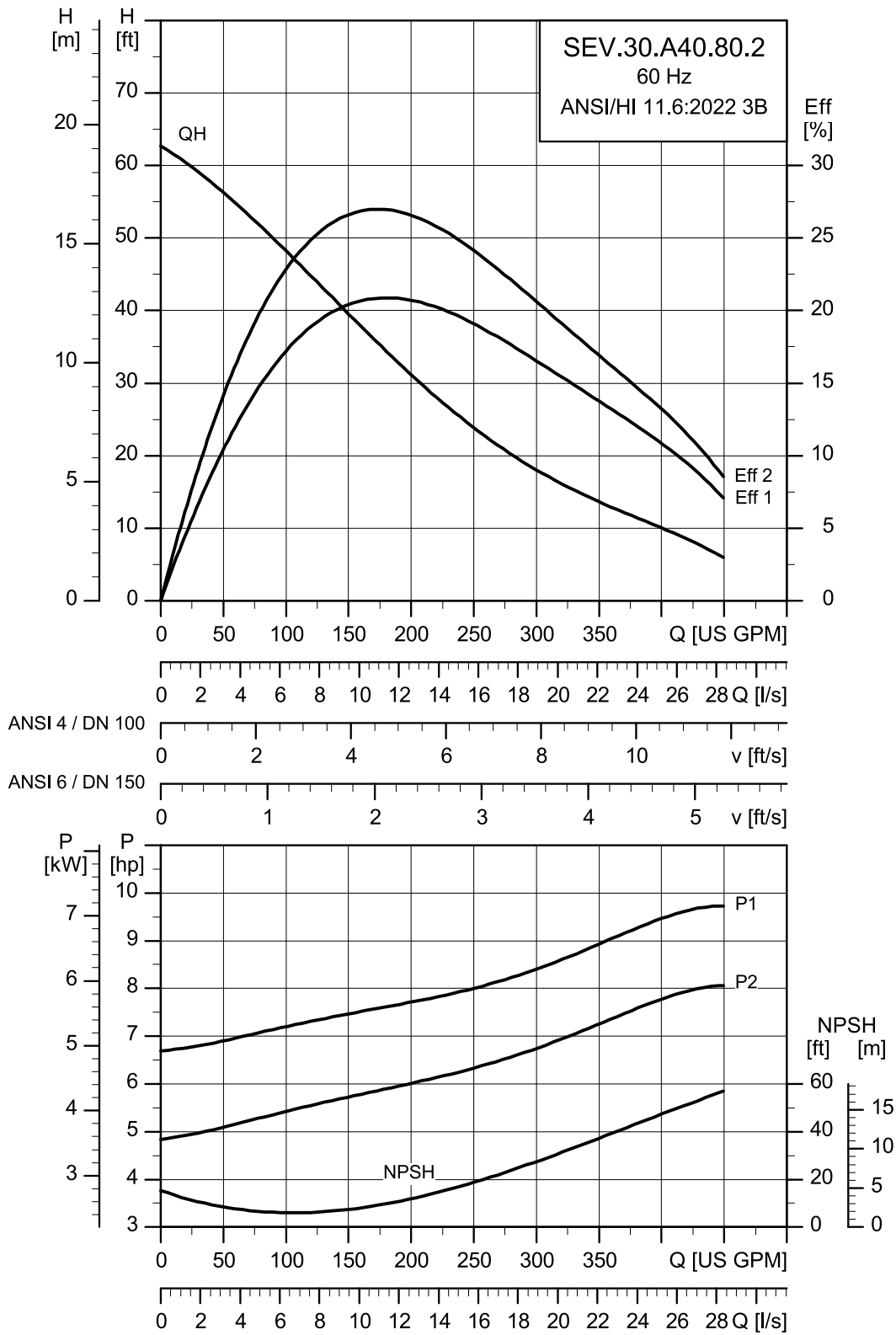

TM086501

Motor data

Pump type	Voltage [V]	P1 [Hp]	P2 [Hp]	No. of poles	RPM	Starting method	I _N [A]	I _{start} [A]	η _{motor} [%]			Cos φ		
									1/2	3/4	1/1	1/2	3/4	1/1
SEV.30.A40.80.A.EX.2.61R	230	9.705	8	2	3.510	Star-delta (YD)	19.3	214	85.8	87.9	88.2	0.76	0.85	0.88
	460								10.9	146	83.5	86.9	88.2	0.56

Pump data

Pump type	Impeller diameter [mm]	Moment of inertia (impeller) [kgm ²]	Outlet flange pressure (according to EN 1092-2)	Max. installation depth	Moment of inertia (motor) [kgm ²]	Breakdown torque M _{max} [Nm]
SEV.30.A40.80.A.EX.2.61R	142	0.00652	PN 10	12	0.00800	74.5
						104

SEV.30.A40.100.2.6

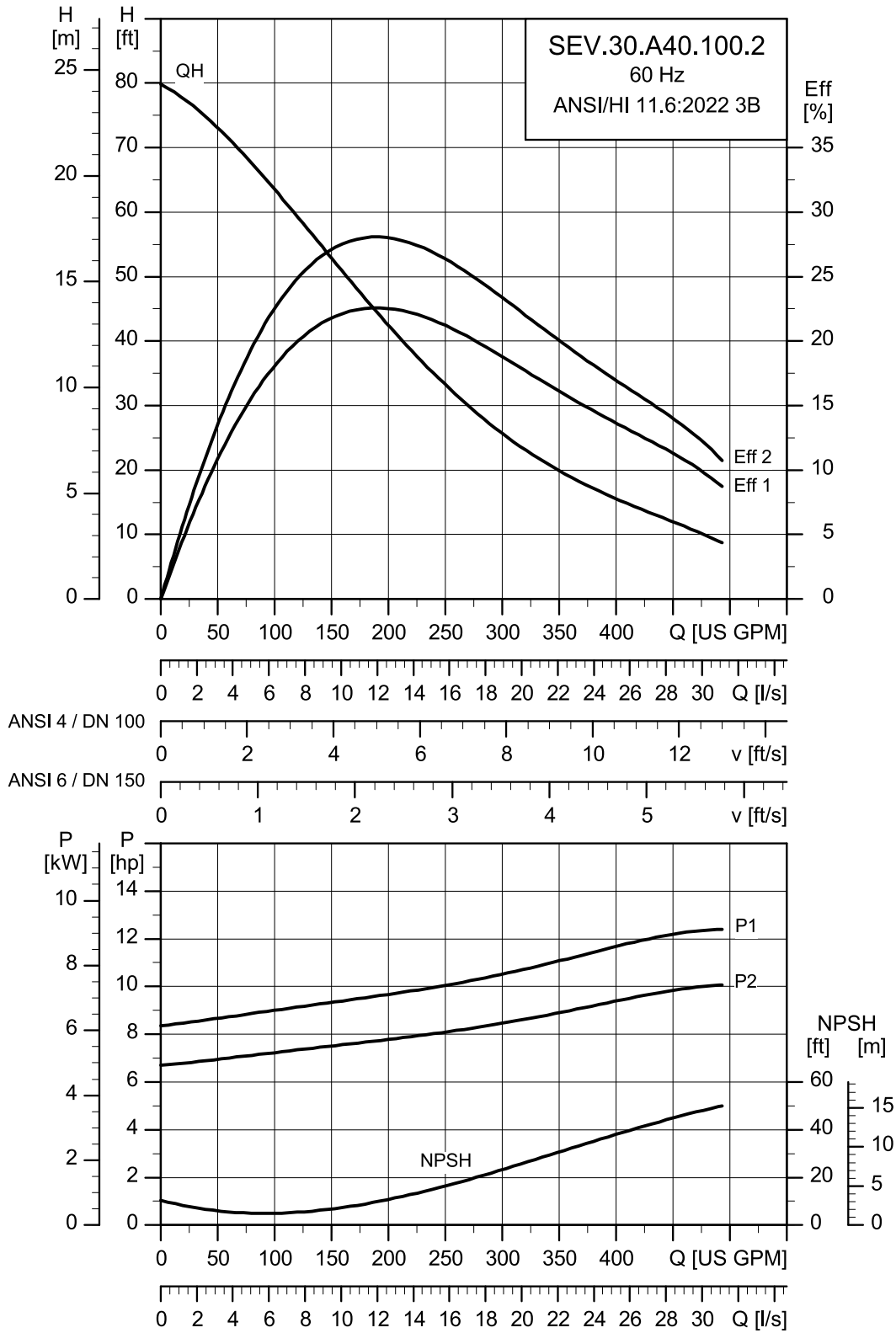

TM086493

Motor data

Pump type	Voltage [V]	P1 [Hp]	P2 [Hp]	No. of poles	RPM	Starting method	I _N [A]	I _{start} [A]	η _{motor} [%]			Cos φ		
									1/2	3/4	1/1	1/2	3/4	1/1
SEV.30.A40.100.A.EX.2.61R	230	12.371	10	2	3.484	Star-delta (YD)	23.72	214	87.2	88.2	87.7	0.81	0.88	0.9
	460								12.8	146	85.6	88	88.6	0.64

Pump data

Pump type	Impeller diameter [mm]	Moment of inertia (impeller) [kgm ²]	Outlet flange pressure (according to EN 1092-2)	Max. installation depth	Moment of inertia (motor) [kgm ²]	Breakdown torque M _{max} [Nm]
SEV.30.A40.100.A.EX.2.61R	153	0.00734	PN 10	12	0.00800	74.5
						104

SEV.30.A40.125.2.6

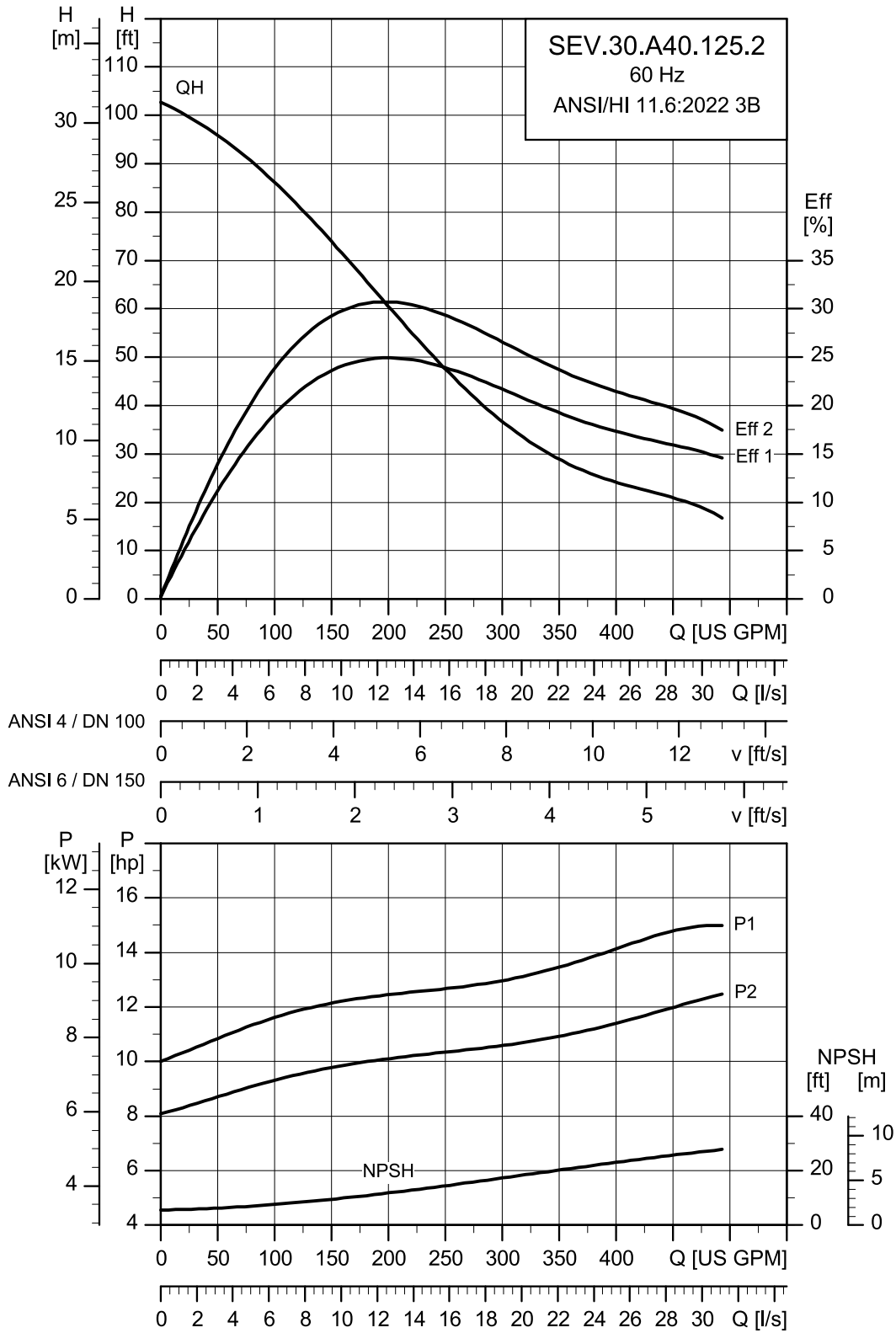

TM086494

Motor data

Pump type	Voltage [V]	P1 [Hp]	P2 [Hp]	No. of poles	RPM	Starting method	I _N [A]	I _{start} [A]	η _{motor} [%]			Cos φ		
									1/2	3/4	1/1	1/2	3/4	1/1
SEV.30.A40.125.A.EX.2.61R	230	14.803	12.5	2	3.496	Star-delta (YD)	34.73	164	90.1	90.1	88.6	0.65	0.73	0.75
	460								20.5	112	86.4	88.5	88.9	0.43

Pump data

Pump type	Impeller diameter [mm]	Moment of inertia (impeller) [kgm ²]	Outlet flange pressure (according to EN 1092-2)	Max. installation depth	Moment of inertia (motor) [kgm ²]	Breakdown torque M _{max} [Nm]
SEV.30.A40.125.A.EX.2.61R	164.5	0.00996	PN 10	12	0.01580	49.5
						71.5

SEV.30.A40.150.2.6

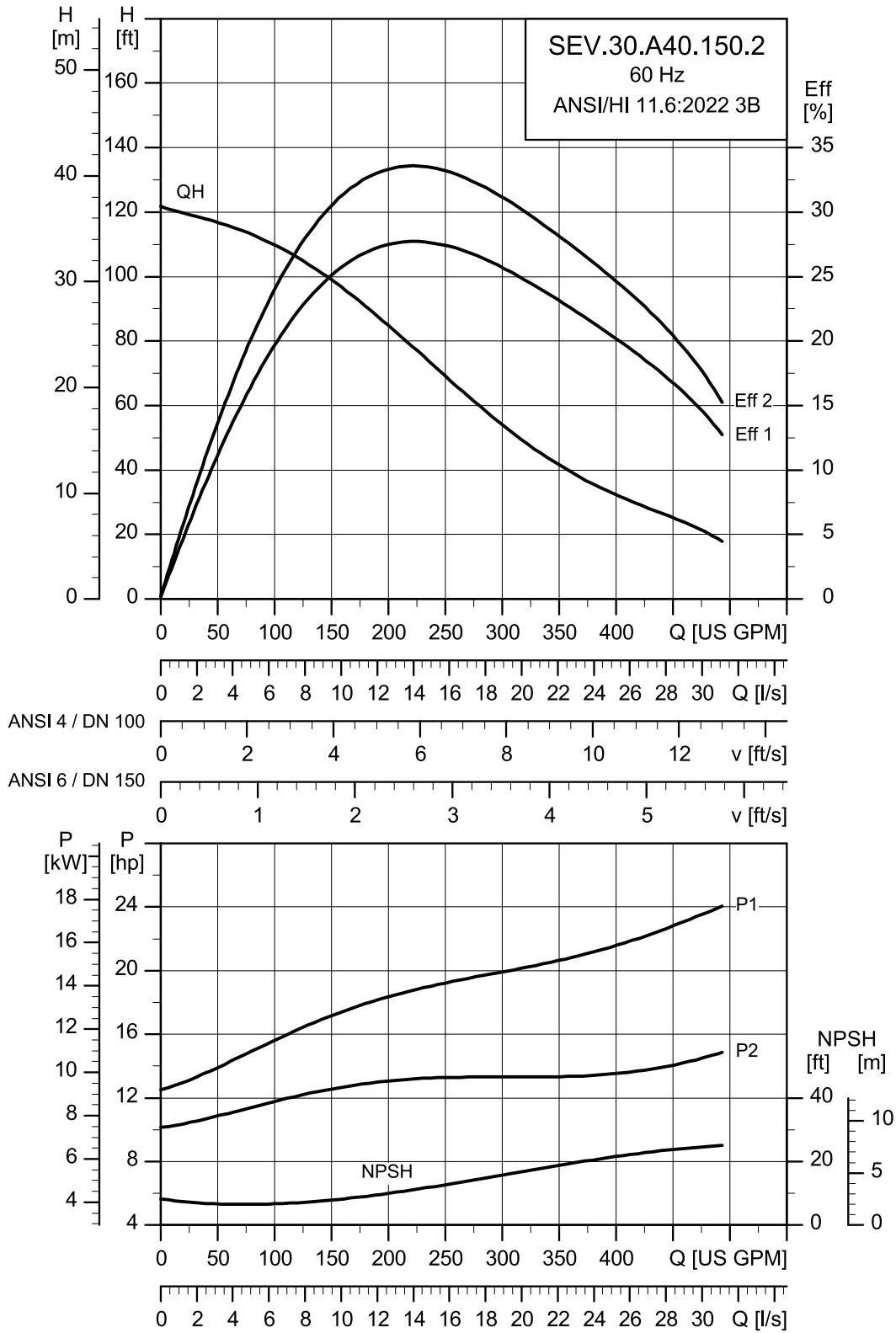

TM086496

Motor data

Pump type	Voltage [V]	P1 [Hp]	P2 [Hp]	No. of poles	RPM	Starting method	I _N [A]	I _{start} [A]	η _{motor} [%]			Cos φ		
									1/2	3/4	1/1	1/2	3/4	1/1
SEV.30.A40.150.A.EX.2.61R	230	17.666	15	2	3.503	Star-delta (YD)	43.78	206	88.8	89.5	88.5	0.54	0.66	0.71
	460								29.7	144	81.8	85.3	86.5	0.33

Pump data

Pump type	Impeller diameter [mm]	Moment of inertia (impeller) [kgm ²]	Outlet flange pressure (according to EN 1092-2)	Max. installation depth	Moment of inertia (motor) [kgm ²]	Breakdown torque M _{max} [Nm]
SEV.30.A40.150.A.EX.2.61R	174	0.01261	PN 10	12	0.01580	65 104

SEV.40.A40.40.4.6

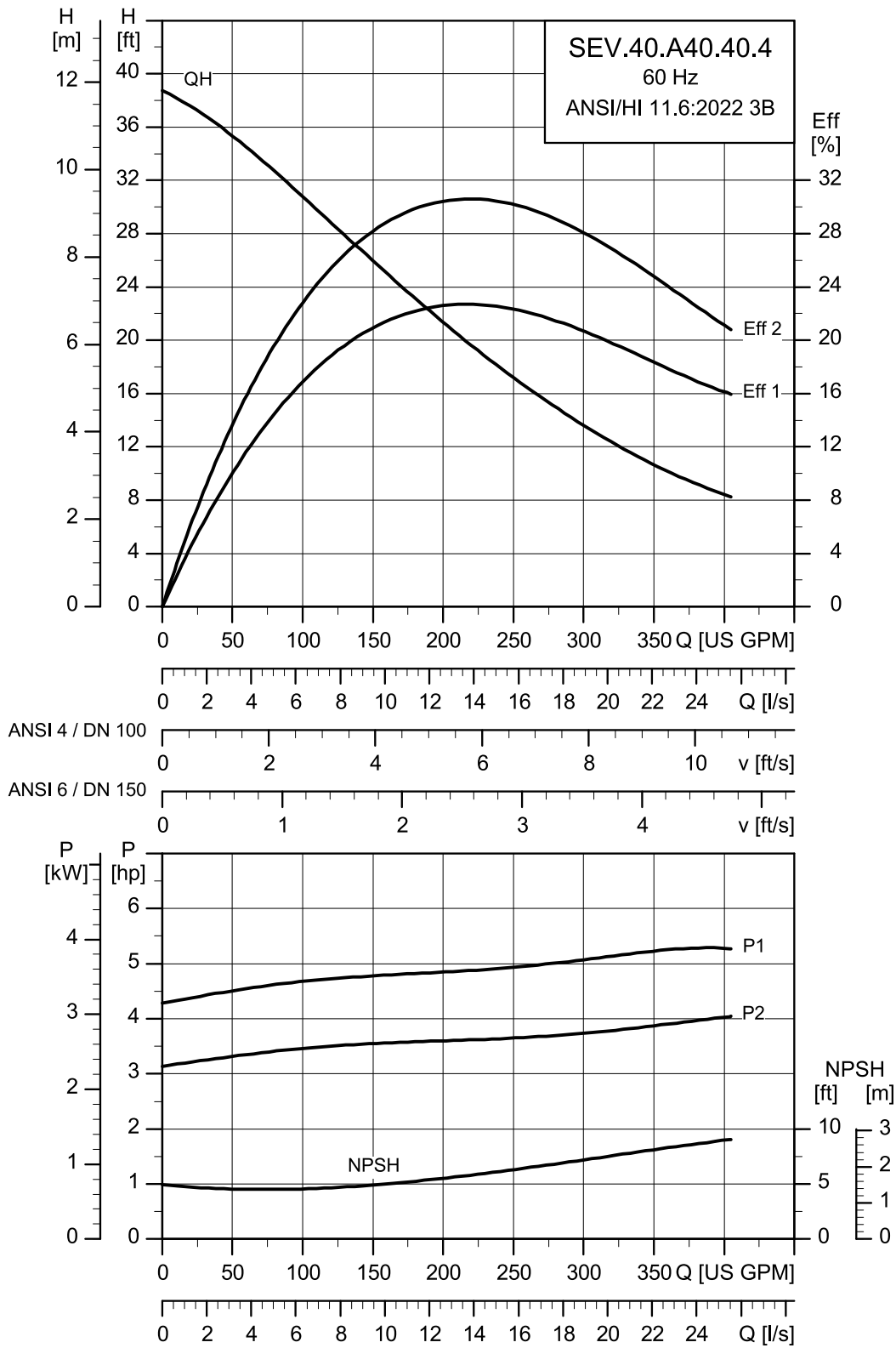

TM086503

Motor data

Pump type	Voltage [V]	P1 [Hp]	P2 [Hp]	No. of poles	RPM	Starting method	I _N [A]	I _{start} [A]	η _{motor} [%]			Cos φ		
									1/2	3/4	1/1	1/2	3/4	1/1
SEV.40.A40.40.A.EX.4.61R	230	5.243	4	4	1.739	Star-delta (YD)	10.59	68	84.7	85.6	84.8	0.69	0.79	0.83
	460								82.6	85.5	86.3	0.55	0.68	0.76

Pump data

Pump type	Impeller diameter [mm]	Moment of inertia (impeller) [kgm ²]	Outlet flange pressure (according to EN 1092-2)	Max. installation depth	Moment of inertia (motor) [kgm ²]	Breakdown torque M _{max} [Nm]
SEV.40.A40.40.A.EX.4.61R	188	0.03881	PN 10	12	0.01040	47.5
						64.5

SEV.40.A40.55.4.6

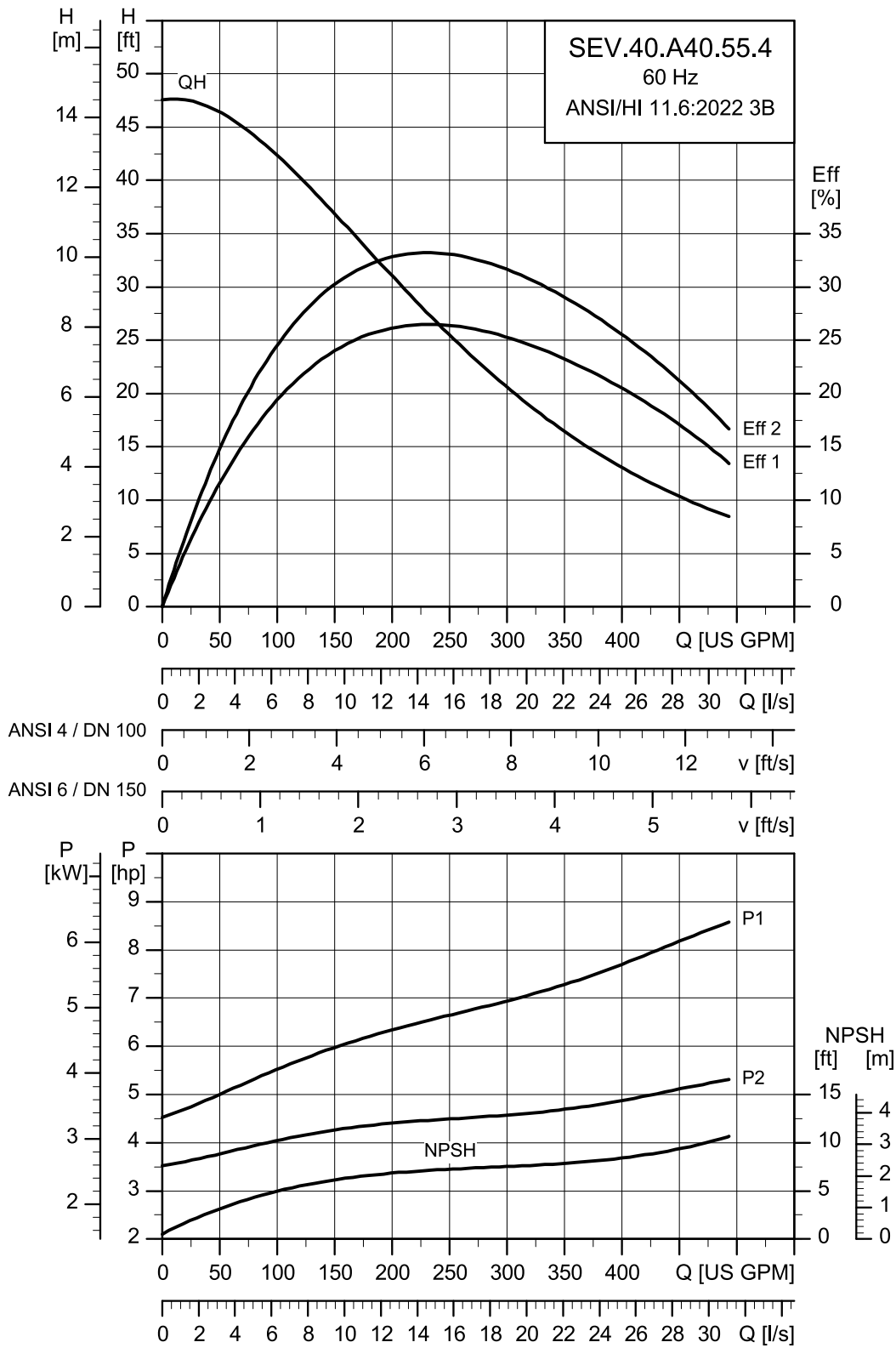

TM086504

Motor data

Pump type	Voltage [V]	P1 [Hp]	P2 [Hp]	No. of poles	RPM	Starting method	I _N [A]	I _{start} [A]	η _{motor} [%]			Cos φ		
									1/2	3/4	1/1	1/2	3/4	1/1
SEV.40.A40.55.A.EX.4.61R	230	6.65	5.5	4	1.741	Star-delta (YD)	14.04	84	86.8	86.9	85.5	0.72	0.8	0.83
	460								7.26	58.5	85.7	87.6	87.7	0.59

Pump data

Pump type	Impeller diameter [mm]	Moment of inertia (impeller) [kgm ²]	Outlet flange pressure (according to EN 1092-2)	Max. installation depth	Moment of inertia (motor) [kgm ²]	Breakdown torque M _{max} [Nm]
SEV.40.A40.55.A.EX.4.61R	200	0.04060	PN 10	12	0.01280	52
						71

SEV.40.A40.75.4.6

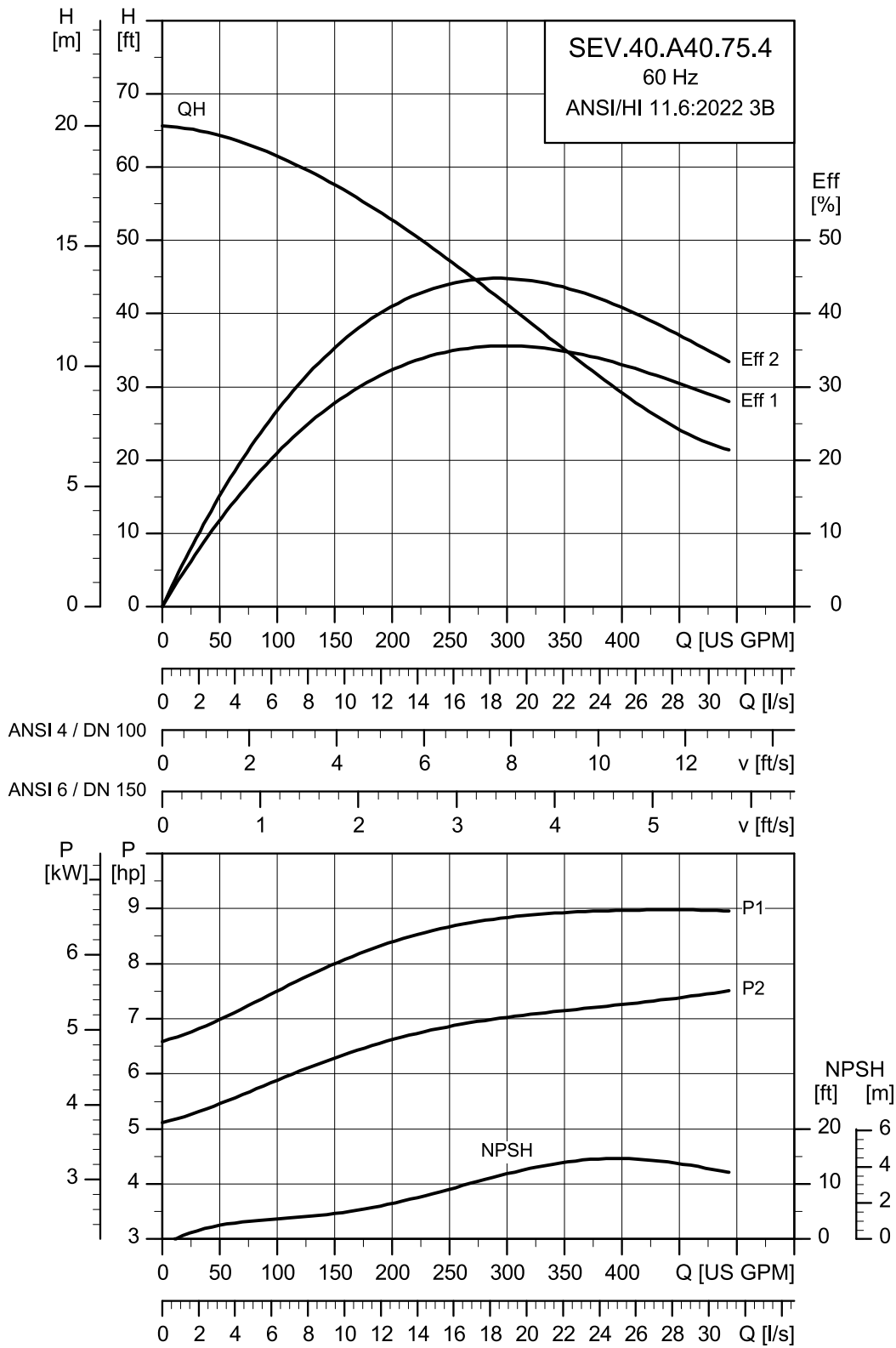

TM086505

Motor data

Pump type	Voltage [V]	P1 [Hp]	P2 [Hp]	No. of poles	RPM	Starting method	I _N [A]	I _{start} [A]	η _{motor} [%]			Cos φ		
									1/2	3/4	1/1	1/2	3/4	1/1
SEV.40.A40.75.A.EX.4.61R	230	8.799	7.5	4	1.727	Star-delta (YD)	19.1	120	86.4	86.6	85.1	0.69	0.8	0.85
	460								10.3	82.5	84.4	86.6	86.8	0.54

Pump data

Pump type	Impeller diameter [mm]	Moment of inertia (impeller) [kgm ²]	Outlet flange pressure (according to EN 1092-2)	Max. installation depth	Moment of inertia (motor) [kgm ²]	Breakdown torque M _{max} [Nm]
SEV.40.A40.75.A.EX.4.61R	226	0.04492	PN 10	12	0.01420	89 120

SEV.40.A40.100.4.6

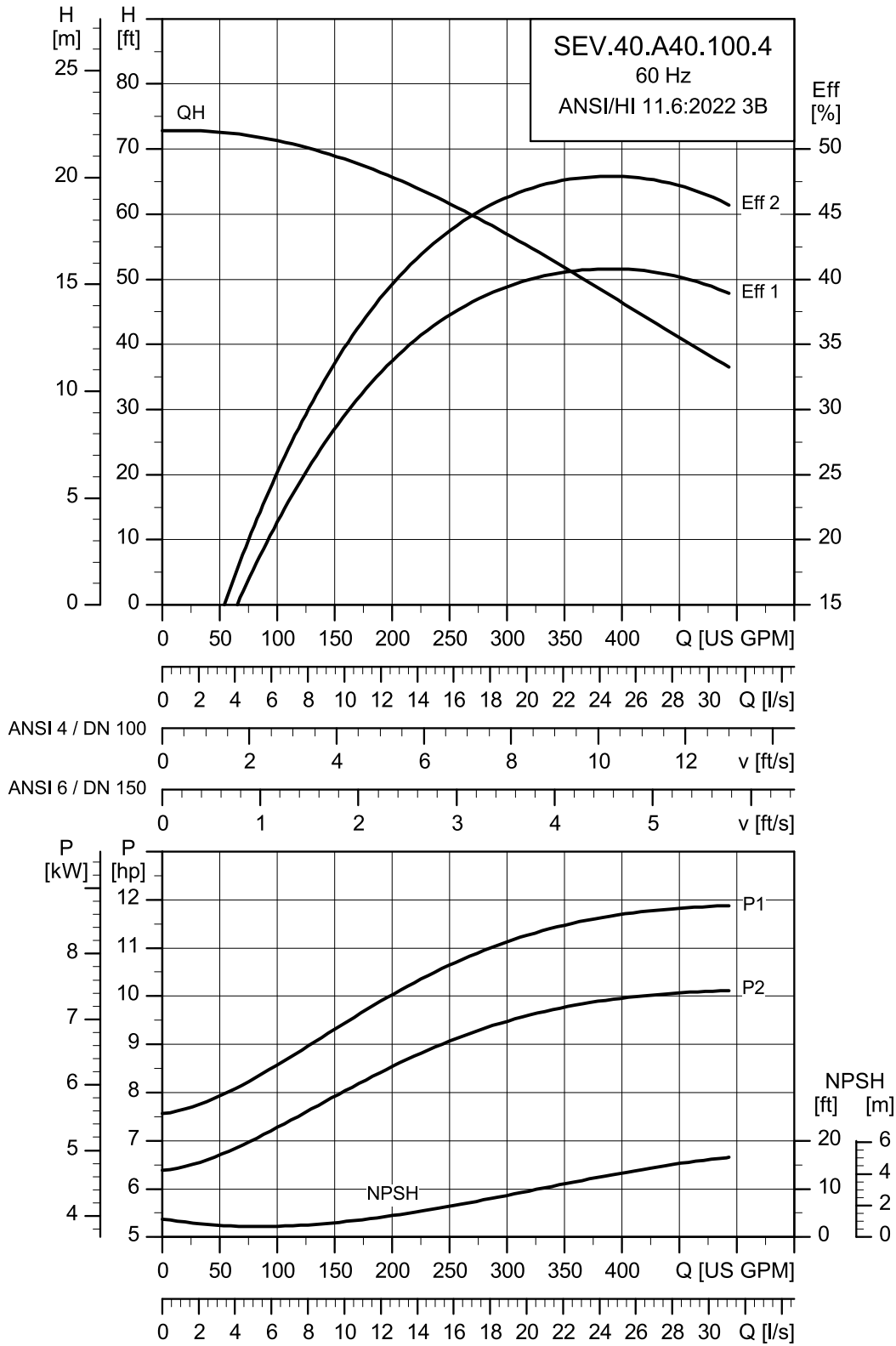

TM086502

Motor data





Pump type	Voltage [V]	P1 [Hp]	P2 [Hp]	No. of poles	RPM	Starting method	I _N [A]	I _{start} [A]	η _{motor} [%]			Cos φ		
									1/2	3/4	1/1	1/2	3/4	1/1
SEV.30.A40.100.A.EX.2.61R	230	12.371	10	2	3.484	Star-delta (YD)	23.72	214	87.2	88.2	87.7	0.81	0.88	0.9
	460								12.8	146	85.6	88	88.6	0.64



Pump data

Pump type	Impeller diameter [mm]	Moment of inertia (impeller) [kgm ²]	Outlet flange pressure (according to EN 1092-2)	Max. installation depth	Moment of inertia (motor) [kgm ²]	Breakdown torque M _{max} [Nm]
SEV.30.A40.100.A.EX.2.61R	153	0.00734	PN 10	12	0.00800	74.5
						104

10. Accessories

Installation systems

Picture	Description	Dimensions	Material	SE1.20.A25	SE1.20.A30	SE1.30.A30	SE1.30.A40	SE1.40.A40	SE1.40.A60	SEV.25.A25	SEV.25.A30	SEV.30.A30	SEV.30.A40	SEV.40.A40	Product number			
	Complete auto-coupling system, including guide claw, base plate and upper guide rail bracket. Cast iron, epoxy-coated. With bolts, nuts, and gaskets. Note: If your guide rails exceed 4 meters, consider using intermediate guide rail brackets to support your system.	2.5"	Cast iron	•						•					97626234			
		3"			•	•						•	•			97626236		
		3"/2.5"		•								•					97626237	
		4"						•	•					•	•		97626238	
		4"/3"			•	•							•	•			97626239	
		6"									•							97626240
		6"/4"							•	•					•	•		97626241
	Intermediate guide rail brackets in stainless steel.	2.5"	Stainless steel	•						•					97929392			
		3"			•						•	•			97929394			
		4"				•	•						•	•		97929396		
		6"								•							97929398	
	Ring stand with flanged 90° elbow and hose connection. With bolts, nuts, and gaskets.	2.5"/2.5"	Cast iron, epoxy-coated	•							•				97632115			
		2.5"/3"			•											97632165		
		3"/2.5"										•					97632219	
		3"/3"											•	•			97632227	
		4"/3"			•												97632281	
		3"/4"													•		97632229	
		4"/4"					•									•	97632278	
		6"/4"		Galvanised steel						•							97632370	
	Ring stand with flanged 90° elbow and outside thread connection. With bolts, nuts, and gaskets.	6"/6"	Galvanised steel						•						97632372			
		2.5"/2.5"	Cast iron, epoxy-coated	•								•				97632119		
		2.5"/3"			•											97632166		
		3"/2.5"										•					97632226	
		3"/3"											•	•			97632228	
		4"/3"			•												97632283	
		3"/4"													•		97632241	
		4"/4"					•								•		97632280	
6"/4"	Galvanised steel							•							97632371			
6"/6"	Galvanised steel							•						97632373				

Picture	Description	Dimensions	Material	SE1.20.A25	SE1.20.A30	SE1.30.A30	SE1.30.A40	SE1.40.A40	SE1.40.A60	SEV.25.A25	SEV.25.A30	SEV.30.A30	SEV.30.A40	SEV.40.A40	Product number		
	Brackets for horizontal dry installation.	2.5"	Galvanised steel	•	•										93086375		
		2.5"		•	•										93086379		
		3"										•	•			93086381	
		3"												•	•	93086381	
		3"										•	•	•	•	93086383	
	With bolts, gaskets and anchor bolts.	3"	Galvanised steel									•	•		93086383		
		3"											•	•	93086385		
		4"				•	•									93086387	
		4"				•	•								•	93086389	
		4"				•	•								•	93086401	
		6"								•	•						93086402
		6"								•	•						93086403

Service sledge

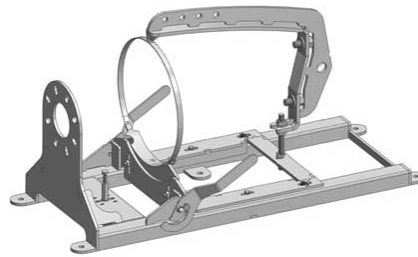

TM080185

Pump to be installed					
Pump/Impeller type	Pump passage [in]	Pump outlet [in]	Power [Hp]	Poles	Service sledge product number
SE1	2	3	3	2	98827089
SE1	2	3	4	2	
SE1	2	3.5	3	2	
SE1	2	3.5	4	2	
SEV	3	3	3	2	98902585
SEV	3	3	4	2	
SEV	3	3.5	3	2	
SEV	3	3.5	4	2	
SE1	3.5	3.5	2	4	98902589
SE1	3.5	3.5	3	4	
SE1	3.5	4	2	4	
SE1	3.5	4	3	4	
SEV	3.5	3.5	15	4	98902589
SEV	3.5	3.5	13	4	
SEV	3.5	3.5	2	4	
SEV	3.5	3.5	3	4	
SEV	3.5	4	15	4	98902589
SEV	3.5	4	13	4	
SEV	3.5	4	2	4	
SEV	3.5	4	3	4	

Pump to be installed					
Pump/Impeller type	Pump passage [in]	Pump outlet [in]	Power [Hp]	Poles	Service sledge product number
SE1	2	3	5	2	98827090
SE1	2	3	5	2	
SEV	3	3	5	2	9890282
SEV	3	3.5	5	2	
SEV	3.5	3.5	5	4	9890283
SEV	3.5	3.5	5	2	
SEV	3.5	3.5	8	2	
SEV	3.5	3.5	10	2	
SEV	3.5	4	5	4	
SEV	3.5	4	5	2	
SEV	3.5	4	8	2	
SEV	3.5	4	10	2	
SE1	3.5	3.5	4	4	
SE1	3.5	3.5	5	4	
SE1	3.5	3.5	7	4	
SE1	3.5	4	4	4	
SE1	3.5	4	5	4	
SE1	3.5	4	7	4	
SEV	4	4	5	4	9890286
SEV	4	4	5	4	
SEV	4	4	8	4	
SE1	4	4	5	4	9890287
SE1	4	4	7	4	
SE1	4	10	5	4	
SE1	4	10	7	4	
SEV	3.5	3.5	92	2	98827091
SEV	3.5	3.5	15	2	
SEV	3.5	4	15	2	
SEV	3.5	4	15	2	
SE1	3.5	3.5	10	4	
SE1	3.5	4	10	4	
SEV	4	4	10	4	9890288
SE1	4	4	10	4	9890289
SE1	4	10	10	4	

Horizontal bracket installation

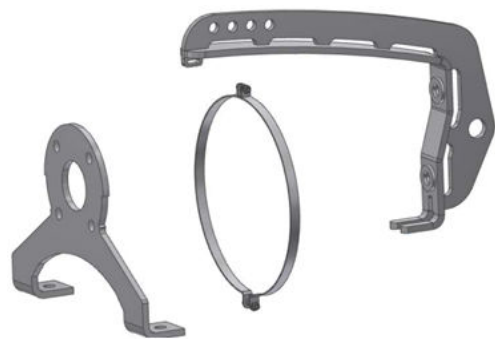

TM080184

Pump to be installed					
Pump/Impeller type	Pump passage [in]	Pump outlet [in]	Power [Hp]	Poles	Horizontal bracket product number
SE1	2	2.5	3	2	
SE1	2	2.5	4	2	
SE1	2	3	3	2	98902621
SE1	2	3	4	2	
SEV	2.5	2.5	3	2	
SEV	2.5	2.5	4	2	
SEV	2.5	3	3	2	
SEV	2.5	3	4	2	
SE1	3	3	2	4	
SE1	3	3	3	4	
SE1	3	4	2	4	
SE1	3	4	3	4	
SEV	3	3	15	4	98902622
SEV	3	3	13	4	
SEV	3	3	2	4	
SEV	3	3	3	4	
SEV	3	4	15	4	
SEV	3	4	13	4	
SEV	3	4	2	4	
SEV	3	4	3	4	
SE1	2	2.5	5	2	
SE1	2	2.5	5	2	98902623
SEV	2.5	2.5	5	2	
SEV	2.5	3	5	2	
SEV	3	3	5	4	
SEV	3	3	5	2	
SEV	3	3	8	2	
SEV	3	3	10	2	
SEV	3	4	5	4	
SEV	3	4	5	2	
SEV	3	4	8	2	
SEV	3	4	10	2	98902625
SE1	3	3	4	4	
SE1	3	3	5	4	
SE1	3	3	7	4	
SE1	3	4	4	4	
SE1	3	4	5	4	
SE1	3	4	7	4	
SEV	4	4	5	4	
SEV	4	4	5	4	
SEV	4	4	8	4	
SE1	4	4	5	4	
SE1	4	4	7	4	
SE1	4	6	5	4	98902626
SE1	4	6	7	4	

Pump to be installed					
Pump/Impeller type	Pump passage [in]	Pump outlet [in]	Power [Hp]	Poles	Horizontal bracket product number
SEV	3	3	92	2	
SEV	3	3	15	2	
SEV	3	4	15	2	
SEV	3	4	15	2	98902628
SE1	3	3	10	4	
SE1	3	4	10	4	
SEV	4	4	10	4	
SE1	4	4	10	4	
SE1	4	6	10	4	98902630

Other accessories

Picture	Description	Max. load [lb (kg)]	SE1.20.A25	SE1.20.A30	SE1.30.A30	SE1.30.A40	SE1.40.A40	SE1.40.A60	SEV.25.A25	SEV.25.A30	SEV.30.A30	SEV.30.A40	SEV.40.A40	Product number
	13 ft (4 m) hot dip galvanized lifting chain with lifting link and safety hook. With certificates.		•	•	•	•	•	•	•	•	•	•	•	98425760
	20 ft (6 m) hot dip galvanized lifting chain with lifting link and safety hook. With certificates.		•	•	•	•	•	•	•	•	•	•	•	98425781
	26 ft (8 m) hot dip galvanized lifting chain with lifting link and safety hook. With certificates.	1763 (800)	•	•	•	•	•	•	•	•	•	•	•	98425782
	33 ft (10 m) hot dip galvanized lifting chain with lifting link and safety hook. With certificates.		•	•	•	•	•	•	•	•	•	•	•	98425783
	40 ft (12 m) hot dip galvanized lifting chain with lifting link and safety hook. With certificates.		•	•	•	•	•	•	•	•	•	•	•	96735557
	13 ft (4 m) stainless steel lifting chain with lifting link and safety hook. With certificates.		•	•	•	•	•	•	•	•	•	•	•	98425797
	20 ft (6 m) stainless steel lifting chain with lifting link and safety hook. With certificates.		•	•	•	•	•	•	•	•	•	•	•	98425798
	26 ft (8 m) stainless steel lifting chain with lifting link and safety hook. With certificates.	1763 (800)	•	•	•	•	•	•	•	•	•	•	•	98425799
	33 ft (10 m) stainless steel lifting chain with lifting link and safety hook. With certificates.		•	•	•	•	•	•	•	•	•	•	•	98425800
	40 ft (12 m) stainless steel lifting chain with lifting link and safety hook. With certificates.		•	•	•	•	•	•	•	•	•	•	•	96735569

11. Dimensions and weights

Dimensions

Pumps without accessories

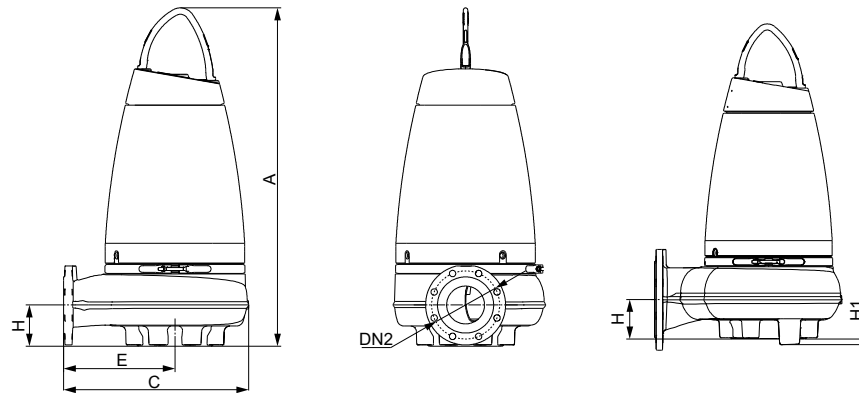
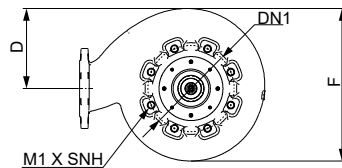

DN1	Size of suction flange
DN2	Size of discharge flange
M1	Bolt size on inlet flange
SNH	Number of holes on inlet flange

TM086248

Pump type	A [in]	C [in]	D [in]	E [in]	F [in]	H [in]	H1 [in]	DN1 [mm]	DN2 [in]	M1	SNH
SE1.20.A25.30.A.EX.2.60R.B	29.5	14.5	6.7	8.5	12.7	2.6	1	140	2.6	M16	4
SE1.20.A25.30.A.EX.2.60H.B	29.5	14.5	6.7	8.5	12.7	2.6	1	140	2.6	M16	4
SE1.20.A25.40.A.EX.2.60R.B	29.5	14.5	6.7	8.5	12.7	2.6	1	140	2.6	M16	4
SE1.20.A25.40.A.EX.2.60H.B	29.5	14.5	6.7	8.5	12.7	2.6	1	140	2.6	M16	4
SE1.20.A25.55.A.EX.2.61R.B	32.6	16.1	7.8	8.9	15	2.7	1	140	2.6	M16	4
SE1.20.A30.30.A.EX.2.60R.B	29.8	14.5	6.7	8.5	12.7	2.6	1.3	140	3.1	M16	4
SE1.20.A30.30.A.EX.2.60H.B	29.8	14.5	6.7	8.5	12.7	2.6	1.3	140	3.1	M16	4
SE1.20.A30.40.A.EX.2.60R.B	29.8	14.5	6.7	8.5	12.7	2.6	1.3	140	3.1	M16	4
SE1.20.A30.40.A.EX.2.60H.B	29.8	14.5	6.7	8.5	12.7	2.6	1.3	140	3.1	M16	4
SE1.20.A30.55.A.EX.2.61R.B	32.6	16.1	7.8	8.9	15	2.7	0.9	140	3.1	M16	4
SE1.30.A30.20.A.EX.4.60R.B	30.4	17.1	6.9	10.7	13	3.6	0.3	191	3.1	M16	8
SE1.30.A30.20.A.EX.4.60H.B	30.4	17.1	6.9	10.7	13	3.6	0.3	191	3.1	M16	8
SE1.30.A30.30.A.EX.4.60R.B	30.4	17.1	6.9	10.7	13	3.6	0.3	191	3.1	M16	8
SE1.30.A30.30.A.EX.4.60H.B	30.4	17.1	6.9	10.7	13	3.6	0.3	191	3.1	M16	8
SE1.30.A30.40.A.EX.4.61R.B	34.5	20	8	12.6	15.2	4.7	0	191	3.1	M16	8
SE1.30.A30.55.A.EX.4.61R.B	34.5	20	8	12.6	15.2	4.7	0	191	3.1	M16	8
SE1.30.A30.75.A.EX.4.61R.B	34.5	20	8	12.6	15.2	4.7	0	191	3.1	M16	8

Pump type	A [in]	C [in]	D [in]	E [in]	F [in]	H [in]	H1 [in]	DN1 [mm]	DN2 [in]	M1	SNH
SE1.30.A30.100.A.EX.4.61R.B	37	20.8	8.5	12.9	16.4	4.7	0	191	3.1	M16	8
SE1.30.A40.20.A.EX.4.60R.B	30.8	17.1	6.9	10.7	13	3.6	0.7	191	3.9	M16	8
SE1.30.A40.20.A.EX.4.60H.B	30.8	17.1	6.9	10.7	13	3.6	0.7	191	3.9	M16	8
SE1.30.A40.30.A.EX.4.60R.B	30.8	17.1	6.9	10.7	13	3.6	0.7	191	3.9	M16	8
SE1.30.A40.30.A.EX.4.60H.B	30.8	17.1	6.9	10.7	13	3.6	0.7	191	3.9	M16	8
SE1.30.A40.40.A.EX.4.61R.B	34.5	20	8	12.6	15.2	4.7	0	191	3.9	M16	8
SE1.30.A40.55.A.EX.4.61R.B	34.5	20	8	12.6	15.2	4.7	0	191	3.9	M16	8
SE1.30.A40.75.A.EX.4.61R.B	34.5	20	8	12.6	15.2	4.7	0	191	3.9	M16	8
SE1.30.A40.100.A.EX.4.61R.B	37	20.8	8.5	12.9	16.4	4.7	0	191	3.9	M16	8
SE1.40.A40.55.A.EX.4.61R.B	34.7	20.7	8.9	12.6	16.3	4.5	0	241	3.9	M20	8
SE1.40.A40.75.A.EX.4.61R.B	34.7	20.7	8.9	12.6	16.3	4.5	0	241	3.9	M20	8
SE1.40.A40.100.A.EX.4.61R.B	37.3	20.4	8.8	12.3	16.8	4.5	0	241	3.9	M20	8
SE1.40.A60.55.A.EX.4.61R.B	34.7	20.7	8.9	12.6	16.2	4.4	0.6	241	5.9	M20	8
SE1.40.A60.75.A.EX.4.61R.B	34.7	20.7	8.9	12.6	16.2	4.4	0.6	241	5.9	M20	8
SE1.40.A60.100.A.EX.4.61R.B	37.3	20.6	9.5	12.1	17.5	4.4	0.6	241	5.9	M20	8
SEV.25.A25.30.A.EX.2.60R	30.2	15.6	6.7	9.7	12.6	4	0	152	2.6	M16	4
SEV.25.A25.30.A.EX.2.60H	30.2	15.6	6.7	9.7	12.6	4	0	152	2.6	M16	4
SEV.25.A25.40.A.EX.2.60R	30.2	15.6	6.7	9.7	12.6	4	0	152	2.6	M16	4
SEV.25.A25.40.A.EX.2.60H	30.2	15.6	6.7	9.7	12.6	4	0	152	2.6	M16	4
SEV.25.A25.55.A.EX.2.61R	33.3	18	7.8	10.9	14.9	4.2	0	152	2.6	M16	4
SEV.25.A30.30.A.EX.2.60R	30.2	15.6	6.7	9.7	12.6	4.1	0	152	3.1	M16	4
SEV.25.A30.30.A.EX.2.60H	30.2	15.6	6.7	9.7	12.6	4.1	0	152	3.1	M16	4
SEV.25.A30.40.A.EX.2.60R	30.2	15.6	6.7	9.7	12.6	4.1	0	152	3.1	M16	4
SEV.25.A30.40.A.EX.2.60H	30.2	15.6	6.7	9.7	12.6	4.1	0	152	3.1	M16	4
SEV.25.A30.55.A.EX.2.61R	33.3	18	7.8	10.9	14.9	4.2	0	152	3.1	M16	4
SEV.30.A30.15.A.EX.4.60R	31.2	16.1	6.7	9.5	13.3	4.3	0	152	3.1	M16	8
SEV.30.A30.15.A.EX.4.60H	31.2	16.1	6.7	9.5	13.3	4.3	0	152	3.1	M16	8
SEV.30.A30.18.A.EX.4.60R	31.2	16.1	6.7	9.5	13.3	4.3	0	152	3.1	M16	8
SEV.30.A30.18.A.EX.4.60H	31.2	16.1	6.7	9.5	13.3	4.3	0	152	3.1	M16	8
SEV.30.A30.20.A.EX.4.60R	31.2	16.1	6.7	9.5	13.3	4.3	0	152	3.1	M16	8
SEV.30.A30.20.A.EX.4.60H	31.2	16.1	6.7	9.5	13.3	4.3	0	152	3.1	M16	8
SEV.30.A30.30.A.EX.4.60R	31.2	16.1	6.7	9.5	13.3	4.3	0	152	3.1	M16	8
SEV.30.A30.30.A.EX.4.60H	31.2	16.1	6.7	9.5	13.3	4.3	0	152	3.1	M16	8
SEV.30.A30.55.A.EX.4.61R	34.3	18	7.8	10.9	15	4.1	0	152	3.1	M16	8
SEV.30.A30.80.A.EX.2.61R	34.3	18	7.8	10.9	15	4.1	0	152	3.1	M16	8
SEV.30.A30.100.A.EX.2.61R	34.3	18	7.8	10.9	15	4.1	0	152	3.1	M16	8
SEV.30.A30.125.A.EX.2.61R	36.9	19.3	8.5	11.5	16.2	4.8	0	152	3.1	M16	8
SEV.30.A30.150.A.EX.2.61R	36.9	19.3	8.5	11.5	16.2	4.8	0	152	3.1	M16	8
SEV.30.A40.15.A.EX.4.60R	31.2	16	6.7	9.5	13.2	4.3	0	152	3.9	M16	8
SEV.30.A40.15.A.EX.4.60H	31.2	16	6.7	9.5	13.2	4.3	0	152	3.9	M16	8
SEV.30.A40.18.A.EX.4.60R	31.2	16	6.7	9.5	13.2	4.3	0	152	3.9	M16	8
SEV.30.A40.18.A.EX.4.60H	31.2	16	6.7	9.5	13.2	4.3	0	152	3.9	M16	8
SEV.30.A40.20.A.EX.4.60R	31.2	16	6.7	9.5	13.2	4.3	0	152	3.9	M16	8
SEV.30.A40.20.A.EX.4.60H	31.2	16	6.7	9.5	13.2	4.3	0	152	3.9	M16	8
SEV.30.A40.30.A.EX.4.60R	31.2	16	6.7	9.5	13.2	4.3	0	152	3.9	M16	8
SEV.30.A40.30.A.EX.4.60H	31.2	16	6.7	9.5	13.2	4.3	0	152	3.9	M16	8
SEV.30.A40.55.A.EX.4.61R	34.3	18.4	7.8	11.3	15	4.1	0	152	3.9	M16	8
SEV.30.A40.80.A.EX.2.61R	34.3	18.4	7.8	11.3	15	4.1	0	152	3.9	M16	8
SEV.30.A40.100.A.EX.2.61R	34.3	18.4	7.8	11.3	15	4.1	0	152	3.9	M16	8
SEV.30.A40.125.A.EX.2.61R	36.9	19.7	8.5	11.9	16.2	4.8	0	152	3.9	M16	8
SEV.30.A40.150.A.EX.2.61R	36.9	19.7	8.5	11.9	16.2	4.8	0	152	3.9	M16	8

Pump type	A [in]	C [in]	D [in]	E [in]	F [in]	H [in]	H1 [in]	DN1 [mm]	DN2 [in]	M1	SNH
SEV.40.A40.40.A.EX.4.61R	34.9	18	7.8	10.9	14.9	5.3	0	191	3.9	M16	8
SEV.40.A40.55.A.EX.4.61R	34.9	18	7.8	10.9	14.9	5.3	0	191	3.9	M16	8
SEV.40.A40.75.A.EX.4.61R	34.9	18	7.8	10.9	14.9	5.3	0	191	3.9	M16	8
SEV.40.A40.100.A.EX.4.61R	37.9	19.3	8.5	11.6	16.3	5.7	0	191	3.9	M16	8
SE1.20.A25.55.A.EX.2.61H.B	32.6	16.1	7.8	8.9	15	2.7	1	140	2.6	M16	4
SE1.20.A30.55.A.EX.2.61H.B	32.6	16.1	7.8	8.9	15	2.7	0.9	140	3.1	M16	4
SE1.30.A30.40.A.EX.4.61H.B	34.5	20	8	12.6	15.2	4.7	0	191	3.1	M16	8
SE1.30.A30.55.A.EX.4.61H.B	34.5	20	8	12.6	15.2	4.7	0	191	3.1	M16	8
SE1.30.A30.75.A.EX.4.61H.B	34.5	20	8	12.6	15.2	4.7	0	191	3.1	M16	8
SE1.30.A30.100.A.EX.4.61H.B	37	20.8	8.5	12.9	16.4	4.7	0	191	3.1	M16	8
SE1.30.A40.40.A.EX.4.61H.B	34.5	20	8	12.6	15.2	4.7	0	191	3.9	M16	8
SE1.30.A40.55.A.EX.4.61H.B	34.5	20	8	12.6	15.2	4.7	0	191	3.9	M16	8
SE1.30.A40.75.A.EX.4.61H.B	34.5	20	8	12.6	15.2	4.7	0	191	3.9	M16	8
SE1.30.A40.100.A.EX.4.61H.B	37	20.8	8.5	12.9	16.4	4.7	0	191	3.9	M16	8
SE1.40.A40.55.A.EX.4.61H.B	34.7	20.7	8.9	12.6	16.3	4.5	0	241	3.9	M20	8
SE1.40.A40.75.A.EX.4.61H.B	34.7	20.7	8.9	12.6	16.3	4.5	0	241	3.9	M20	8
SE1.40.A40.100.A.EX.4.61H.B	37.3	20.4	8.8	12.3	16.8	4.5	0	241	3.9	M20	8
SE1.40.A60.55.A.EX.4.61H.B	34.7	20.7	8.9	12.6	16.2	4.4	0.6	241	5.9	M20	8
SE1.40.A60.75.A.EX.4.61H.B	34.7	20.7	8.9	12.6	16.2	4.4	0.6	241	5.9	M20	8
SE1.40.A60.100.A.EX.4.61H.B	37.3	20.6	9.5	12.1	17.5	4.4	0.6	241	5.9	M20	8
SEV.25.A25.55.A.EX.2.61H	33.3	18	7.8	10.9	14.9	4.2	0	152	2.6	M16	4
SEV.25.A30.55.A.EX.2.61H	33.3	18	7.8	10.9	14.9	4.2	0	152	3.1	M16	4
SEV.30.A30.55.A.EX.4.61H	34.3	18	7.8	10.9	15	4.1	0	152	3.1	M16	8
SEV.30.A30.80.A.EX.2.61H	34.3	18	7.8	10.9	15	4.1	0	152	3.1	M16	8
SEV.30.A30.100.A.EX.2.61H	34.3	18	7.8	10.9	15	4.1	0	152	3.1	M16	8
SEV.30.A30.125.A.EX.2.61H	36.9	19.3	8.5	11.5	16.2	4.8	0	152	3.1	M16	8
SEV.30.A30.150.A.EX.2.61H	36.9	19.3	8.5	11.5	16.2	4.8	0	152	3.1	M16	8
SEV.30.A40.55.A.EX.4.61H	34.3	18.4	7.8	11.3	15	4.1	0	152	3.9	M16	8
SEV.30.A40.80.A.EX.2.61H	34.3	18.4	7.8	11.3	15	4.1	0	152	3.9	M16	8
SEV.30.A40.100.A.EX.2.61H	34.3	18.4	7.8	11.3	15	4.1	0	152	3.9	M16	8
SEV.30.A40.125.A.EX.2.61H	36.9	19.7	8.5	11.9	16.2	4.8	0	152	3.9	M16	8
SEV.30.A40.150.A.EX.2.61H	36.9	19.7	8.5	11.9	16.2	4.8	0	152	3.9	M16	8
SEV.40.A40.40.A.EX.4.61H	34.9	18	7.8	10.9	14.9	5.3	0	191	3.9	M16	8
SEV.40.A40.55.A.EX.4.61H	34.9	18	7.8	10.9	14.9	5.3	0	191	3.9	M16	8
SEV.40.A40.75.A.EX.4.61H	34.9	18	7.8	10.9	14.9	5.3	0	191	3.9	M16	8
SEV.40.A40.100.A.EX.4.61H	37.9	19.3	8.5	11.6	16.3	5.7	0	191	3.9	M16	8

Free-standing submerged pump on ring stand

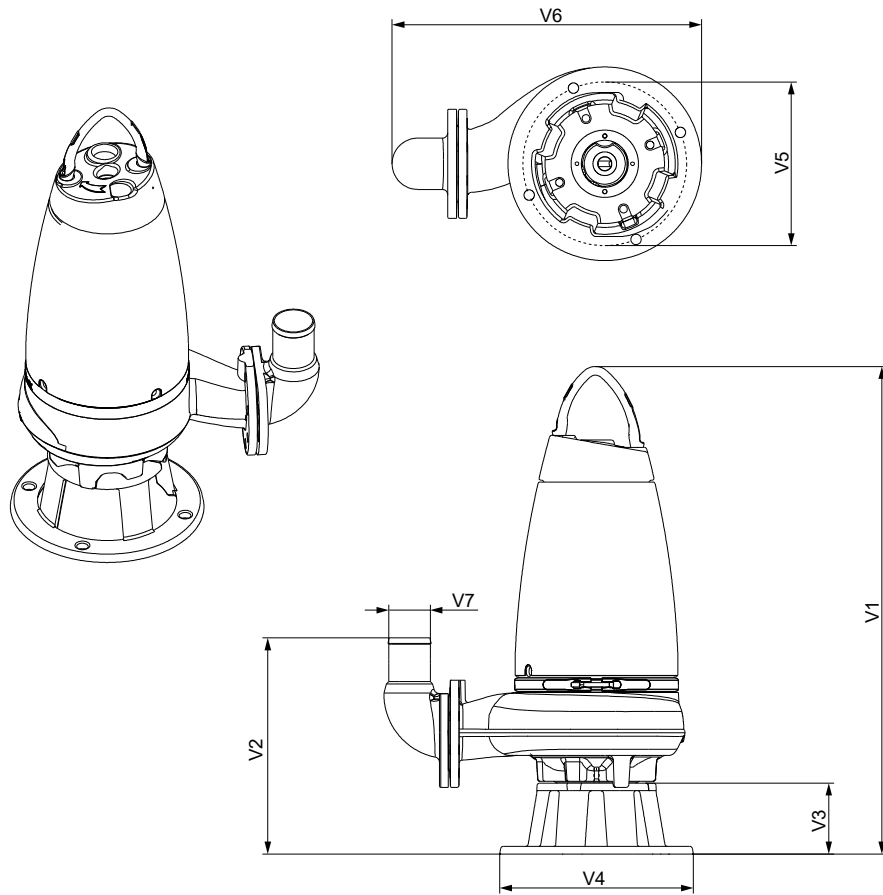

TM086244

Dimensions (inch)

VOE	Diameter								
Pump type	V1	V2	V3	V4	V5	V6	V7	VOE	
SE1.20.A25.30.A.EX.2.60R.B	33.6	14	5.1	12.8	10.6	19.4	2.4	0.8	
SE1.20.A25.30.A.EX.2.60H.B	33.6	14	5.1	12.8	10.6	19.4	2.4	0.8	
SE1.20.A25.40.A.EX.2.60R.B	33.6	14	5.1	12.8	10.6	19.4	2.4	0.8	
SE1.20.A25.40.A.EX.2.60H.B	33.6	14	5.1	12.8	10.6	19.4	2.4	0.8	
SE1.20.A25.55.A.EX.2.61R.B	36.8	14.1	5.1	12.8	10.6	20.6	2.4	0.8	
SE1.20.A30.30.A.EX.2.60R.B	33.6	14.6	5.1	12.8	10.6	19.5	3	0.8	
SE1.20.A30.30.A.EX.2.60H.B	33.6	14.6	5.1	12.8	10.6	19.5	3	0.8	
SE1.20.A30.40.A.EX.2.60R.B	33.6	14.6	5.1	12.8	10.6	19.5	3	0.8	
SE1.20.A30.40.A.EX.2.60H.B	33.6	14.6	5.1	12.8	10.6	19.5	3	0.8	
SE1.20.A30.55.A.EX.2.61R.B	36.8	14.7	5.1	12.8	10.6	20.7	3	0.8	
SE1.30.A30.20.A.EX.4.60R.B	35.2	15.6	5.1	14	11.8	22.3	3	0.8	
SE1.30.A30.20.A.EX.4.60H.B	35.2	15.6	5.1	14	11.8	22.3	3	0.8	
SE1.30.A30.30.A.EX.4.60R.B	35.2	15.6	5.1	14	11.8	22.3	3	0.8	
SE1.30.A30.30.A.EX.4.60H.B	35.2	15.6	5.1	14	11.8	22.3	3	0.8	
SE1.30.A30.40.A.EX.4.61R.B	39.6	16.6	5.1	14	11.8	24.7	3	0.8	
SE1.30.A30.55.A.EX.4.61R.B	39.6	16.6	5.1	14	11.8	24.7	3	0.8	
SE1.30.A30.75.A.EX.4.61R.B	39.6	16.6	5.1	14	11.8	24.7	3	0.8	
SE1.30.A30.100.A.EX.4.61R.B	42.1	16.6	5.1	14	11.8	25.4	3	0.8	
SE1.30.A40.20.A.EX.4.60R.B	35.2	15.7	5.1	14	11.8	23.3	4	0.8	

Pump type	V1	V2	V3	V4	V5	V6	V7	VOE
SE1.30.A40.20.A.EX.4.60H.B	35.2	15.7	5.1	14	11.8	23.3	4	0.8
SE1.30.A40.30.A.EX.4.60R.B	35.2	15.7	5.1	14	11.8	23.3	4	0.8
SE1.30.A40.30.A.EX.4.60H.B	35.2	15.7	5.1	14	11.8	23.3	4	0.8
SE1.30.A40.40.A.EX.4.61R.B	39.6	16.7	5.1	14	11.8	25.6	4	0.8
SE1.30.A40.55.A.EX.4.61R.B	39.6	16.7	5.1	14	11.8	25.6	4	0.8
SE1.30.A40.75.A.EX.4.61R.B	39.6	16.7	5.1	14	11.8	25.6	4	0.8
SE1.30.A40.100.A.EX.4.61R.B	42.1	16.7	5.1	14	11.8	26.4	4	0.8
SE1.40.A40.55.A.EX.4.61R.B	42	17.9	7.3	17.7	15.7	28	4	0.9
SE1.40.A40.75.A.EX.4.61R.B	42	17.9	7.3	17.7	15.7	28	4	0.9
SE1.40.A40.100.A.EX.4.61R.B	44.6	17.9	7.3	17.7	15.7	27.7	4	0.9
SE1.40.A60.55.A.EX.4.61R.B	42	22.4	7.3	17.7	15.7	31.9	5.8	0.9
SE1.40.A60.75.A.EX.4.61R.B	42	22.4	7.3	17.7	15.7	31.9	5.8	0.9
SE1.40.A60.100.A.EX.4.61R.B	44.6	22.4	7.3	17.7	15.7	31.3	5.8	0.9
SEV.25.A25.30.A.EX.2.60R	35.2	15.3	5	13	11	20.7	2.4	0.7
SEV.25.A25.30.A.EX.2.60H	35.2	15.3	5	13	11	20.7	2.4	0.7
SEV.25.A25.40.A.EX.2.60R	35.2	15.3	5	13	11	20.7	2.4	0.7
SEV.25.A25.40.A.EX.2.60H	35.2	15.3	5	13	11	20.7	2.4	0.7
SEV.25.A25.55.A.EX.2.61R	38.3	15.5	5	13	11	22.5	2.4	0.7
SEV.25.A30.30.A.EX.2.60R	35.2	16	5	13	11	20.9	3	0.7
SEV.25.A30.30.A.EX.2.60H	35.2	16	5	13	11	20.9	3	0.7
SEV.25.A30.40.A.EX.2.60R	35.2	16	5	13	11	20.9	3	0.7
SEV.25.A30.40.A.EX.2.60H	35.2	16	5	13	11	20.9	3	0.7
SEV.25.A30.55.A.EX.2.61R	38.3	16.1	5	13	11	22.6	3	0.7
SEV.30.A30.15.A.EX.4.60R	36.3	16.2	5	13	11	20.7	3	0.7
SEV.30.A30.15.A.EX.4.60H	36.3	16.2	5	13	11	20.7	3	0.7
SEV.30.A30.18.A.EX.4.60R	36.3	16.2	5	13	11	20.7	3	0.7
SEV.30.A30.18.A.EX.4.60H	36.3	16.2	5	13	11	20.7	3	0.7
SEV.30.A30.20.A.EX.4.60R	36.3	16.2	5	13	11	20.7	3	0.7
SEV.30.A30.20.A.EX.4.60H	36.3	16.2	5	13	11	20.7	3	0.7
SEV.30.A30.30.A.EX.4.60R	36.3	16.2	5	13	11	20.7	3	0.7
SEV.30.A30.30.A.EX.4.60H	36.3	16.2	5	13	11	20.7	3	0.7
SEV.30.A30.55.A.EX.4.61R	39.5	16.1	5	13	11	22.8	3	0.7
SEV.30.A30.80.A.EX.2.61R	39.4	16	5	13	11	22.6	3	0.7
SEV.30.A30.100.A.EX.2.61R	39.4	16	5	13	11	22.6	3	0.7
SEV.30.A30.125.A.EX.2.61R	41.9	16.7	5	13	11	23.9	3	0.7
SEV.30.A30.150.A.EX.2.61R	41.9	16.7	5	13	11	23.9	3	0.7
SEV.30.A40.15.A.EX.4.60R	36.3	16.3	5	13	11	21.6	4	0.7
SEV.30.A40.15.A.EX.4.60H	36.3	16.3	5	13	11	21.6	4	0.7
SEV.30.A40.18.A.EX.4.60R	36.3	16.3	5	13	11	21.6	4	0.7
SEV.30.A40.18.A.EX.4.60H	36.3	16.3	5	13	11	21.6	4	0.7
SEV.30.A40.20.A.EX.4.60R	36.3	16.3	5	13	11	21.6	4	0.7
SEV.30.A40.20.A.EX.4.60H	36.3	16.3	5	13	11	21.6	4	0.7
SEV.30.A40.30.A.EX.4.60R	36.3	16.3	5	13	11	21.6	4	0.7
SEV.30.A40.30.A.EX.4.60H	36.3	16.3	5	13	11	21.6	4	0.7
SEV.30.A40.55.A.EX.4.61R	39.5	16.3	5	13	11	23.6	4	0.7
SEV.30.A40.80.A.EX.2.61R	39.4	16.1	5	13	11	23.9	4	0.7
SEV.30.A40.100.A.EX.2.61R	39.4	16.1	5	13	11	23.9	4	0.7
SEV.30.A40.125.A.EX.2.61R	41.9	16.9	5	13	11	25.3	4	0.7
SEV.30.A40.150.A.EX.2.61R	41.9	16.9	5	13	11	25.3	4	0.7
SEV.40.A40.40.A.EX.4.61R	40	17.4	5.1	14	11.8	23.6	4	0.8
SEV.40.A40.55.A.EX.4.61R	40	17.4	5.1	14	11.8	23.6	4	0.8

Pump type	V1	V2	V3	V4	V5	V6	V7	VOE
SEV.40.A40.75.A.EX.4.61R	40	17.4	5.1	14	11.8	23.6	4	0.8
SEV.40.A40.100.A.EX.4.61R	43	17.8	5.1	14	11.8	24.9	4	0.8
SE1.20.A25.55.A.EX.2.61H.B	36.8	14.1	5.1	12.8	10.6	20.6	2.4	0.8
SE1.20.A30.55.A.EX.2.61H.B	36.8	14.7	5.1	12.8	10.6	20.7	3	0.8
SE1.30.A30.40.A.EX.4.61H.B	39.6	16.6	5.1	14	11.8	24.7	3	0.8
SE1.30.A30.55.A.EX.4.61H.B	39.6	16.6	5.1	14	11.8	24.7	3	0.8
SE1.30.A30.75.A.EX.4.61H.B	39.6	16.6	5.1	14	11.8	24.7	3	0.8
SE1.30.A30.100.A.EX.4.61H.B	42.1	16.6	5.1	14	11.8	25.4	3	0.8
SE1.30.A40.40.A.EX.4.61H.B	39.6	16.7	5.1	14	11.8	25.6	4	0.8
SE1.30.A40.55.A.EX.4.61H.B	39.6	16.7	5.1	14	11.8	25.6	4	0.8
SE1.30.A40.75.A.EX.4.61H.B	39.6	16.7	5.1	14	11.8	25.6	4	0.8
SE1.30.A40.100.A.EX.4.61H.B	42.1	16.7	5.1	14	11.8	26.4	4	0.8
SE1.40.A40.55.A.EX.4.61H.B	42	17.9	7.3	17.7	15.7	28	4	0.9
SE1.40.A40.75.A.EX.4.61H.B	42	17.9	7.3	17.7	15.7	28	4	0.9
SE1.40.A40.100.A.EX.4.61H.B	44.6	17.9	7.3	17.7	15.7	27.7	4	0.9
SE1.40.A60.55.A.EX.4.61H.B	42	22.4	7.3	17.7	15.7	31.9	5.8	0.9
SE1.40.A60.75.A.EX.4.61H.B	42	22.4	7.3	17.7	15.7	31.9	5.8	0.9
SE1.40.A60.100.A.EX.4.61H.B	44.6	22.4	7.3	17.7	15.7	31.3	5.8	0.9
SEV.25.A25.55.A.EX.2.61H	38.3	15.5	5	13	11	22.5	2.4	0.7
SEV.25.A30.55.A.EX.2.61H	38.3	16.1	5	13	11	22.6	3	0.7
SEV.30.A30.55.A.EX.4.61H	39.5	16.1	5	13	11	22.8	3	0.7
SEV.30.A30.80.A.EX.2.61H	39.4	16	5	13	11	22.6	3	0.7
SEV.30.A30.100.A.EX.2.61H	39.4	16	5	13	11	22.6	3	0.7
SEV.30.A30.125.A.EX.2.61H	41.9	16.7	5	13	11	23.9	3	0.7
SEV.30.A30.150.A.EX.2.61H	41.9	16.7	5	13	11	23.9	3	0.7
SEV.30.A40.55.A.EX.4.61H	39.5	16.3	5	13	11	23.6	4	0.7
SEV.30.A40.80.A.EX.2.61H	39.4	16.1	5	13	11	23.9	4	0.7
SEV.30.A40.100.A.EX.2.61H	39.4	16.1	5	13	11	23.9	4	0.7
SEV.30.A40.125.A.EX.2.61H	41.9	16.9	5	13	11	25.3	4	0.7
SEV.30.A40.150.A.EX.2.61H	41.9	16.9	5	13	11	25.3	4	0.7
SEV.40.A40.40.A.EX.4.61H	40	17.4	5.1	14	11.8	23.6	4	0.8
SEV.40.A40.55.A.EX.4.61H	40	17.4	5.1	14	11.8	23.6	4	0.8
SEV.40.A40.75.A.EX.4.61H	40	17.4	5.1	14	11.8	23.6	4	0.8
SEV.40.A40.100.A.EX.4.61H	43	17.8	5.1	14	11.8	24.9	4	0.8

Submerged pump on auto coupling

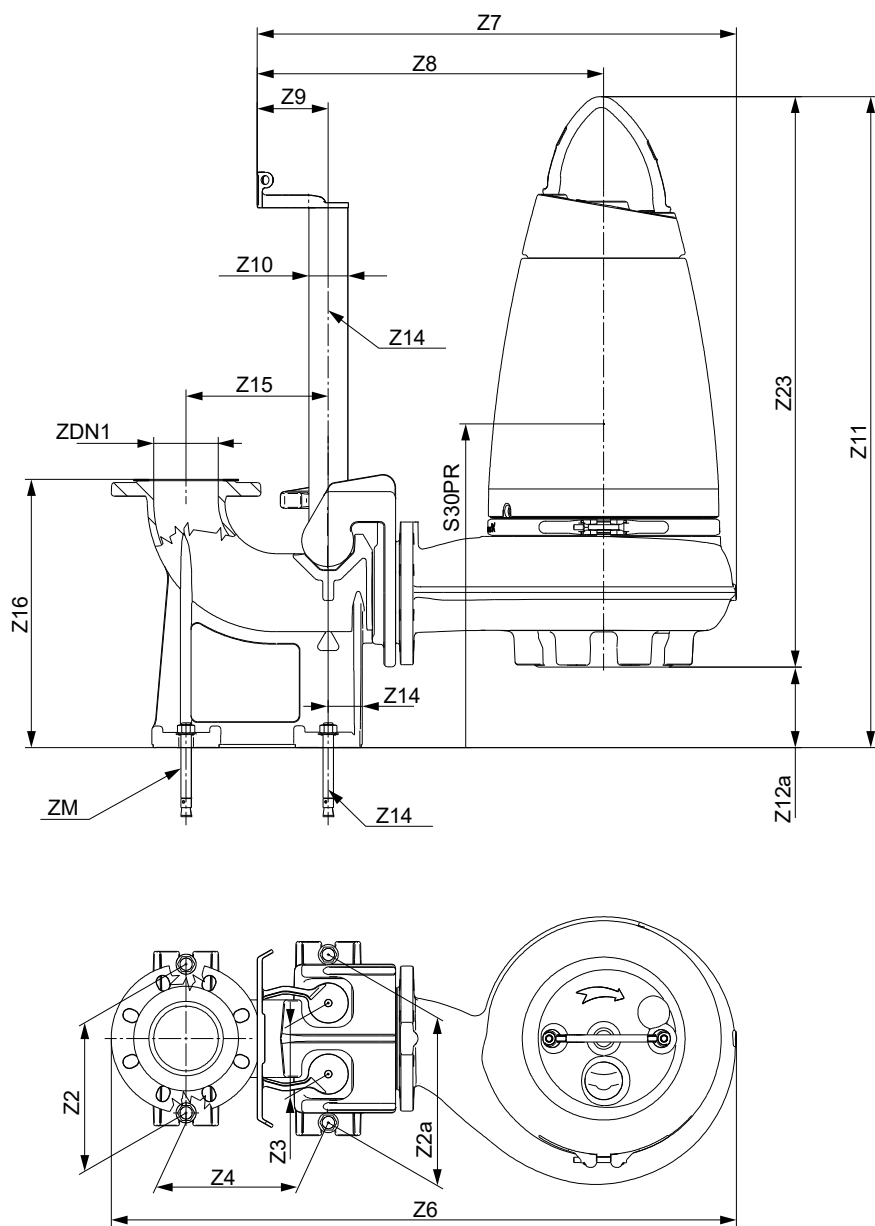

TM086247

Auto-coupling installation dimensions (inch)

ZDN	Size of discharge flange																	
ZM	Size of foundation bolts																	
Pump type	Z2	Z2A	Z3	Z4	Z6	Z7	Z8	Z9	Z10	Z11	Z12A	Z14	Z15	Z16	Z23	S30PR	ZDN	ZM
SE1.20.A25.30.A.EX.2.60R.B	8.3	8.3	3.7	5.5	27.6	20.3	14.3	3.2	1.5	32.4	2	0	6.9	10.6	23.5	9.3	2.6	M16
SE1.20.A25.30.A.EX.2.60H.B	8.3	8.3	3.7	5.5	27.6	20.3	14.3	3.2	1.5	32.4	2	0	6.9	10.6	23.5	9.3	2.6	M16
SE1.20.A25.40.A.EX.2.60R.B	8.3	8.3	3.7	5.5	27.6	20.3	14.3	3.2	1.5	32.4	2	0	6.9	10.6	23.5	9.3	2.6	M16
SE1.20.A25.40.A.EX.2.60H.B	8.3	8.3	3.7	5.5	27.6	20.3	14.3	3.2	1.5	32.4	2	0	6.9	10.6	23.5	9.3	2.6	M16
SE1.20.A25.55.A.EX.2.61R.B	8.3	8.3	3.7	5.5	29.2	21.8	14.7	3.2	1.5	35.5	2	0	6.9	10.6	25.7	9.3	2.6	M16
SE1.20.A30.30.A.EX.2.60R.B	8.7	8.7	3.7	6.3	28.4	20.8	14.8	3.2	1.5	33.7	2	0.5	6.7	13.7	23.5	10.6	3.1	M16
SE1.20.A30.30.A.EX.2.60H.B	8.7	8.7	3.7	6.3	28.4	20.8	14.8	3.2	1.5	33.7	2	0.5	6.7	13.7	23.5	10.6	3.1	M16
SE1.20.A30.40.A.EX.2.60R.B	8.7	8.7	3.7	6.3	28.4	20.8	14.8	3.2	1.5	33.7	2	0.5	6.7	13.7	23.5	10.6	3.1	M16

Pump type	Z2	Z2A	Z3	Z4	Z6	Z7	Z8	Z9	Z10	Z11	Z12A	Z14	Z15	Z16	Z23	S3OPR	ZDN	ZM
SE1.20.A30.40.A.EX.2.60H.B	8.7	8.7	3.7	6.3	28.4	20.8	14.8	3.2	1.5	33.7	2	0.5	6.7	13.7	23.5	10.6	3.1	M16
SE1.20.A30.55.A.EX.2.61R.B	8.7	8.7	3.7	6.3	29.9	22.4	15.2	3.2	1.5	36.9	2	0.5	6.7	13.7	25.7	10.6	3.1	M16
SE1.30.A30.20.A.EX.4.60R.B	8.7	8.7	3.7	6.3	31	23.4	17	3.2	1.5	34.3	3	0.5	6.7	13.7	25.1	11.5	3.1	M16
SE1.30.A30.20.A.EX.4.60H.B	8.7	8.7	3.7	6.3	31	23.4	17	3.2	1.5	34.3	3	0.5	6.7	13.7	25.1	11.5	3.1	M16
SE1.30.A30.30.A.EX.4.60R.B	8.7	8.7	3.7	6.3	31	23.4	17	3.2	1.5	34.3	3	0.5	6.7	13.7	25.1	11.5	3.1	M16
SE1.30.A30.30.A.EX.4.60H.B	8.7	8.7	3.7	6.3	31	23.4	17	3.2	1.5	34.3	3	0.5	6.7	13.7	25.1	11.5	3.1	M16
SE1.30.A30.40.A.EX.4.61R.B	8.7	8.7	3.7	6.3	33.9	26.3	18.9	3.2	1.5	37.7	3	0.5	6.7	13.7	28.5	11.5	3.1	M16
SE1.30.A30.55.A.EX.4.61R.B	8.7	8.7	3.7	6.3	33.9	26.3	18.9	3.2	1.5	37.7	3	0.5	6.7	13.7	28.5	11.5	3.1	M16
SE1.30.A30.75.A.EX.4.61R.B	8.7	8.7	3.7	6.3	33.9	26.3	18.9	3.2	1.5	37.7	3	0.5	6.7	13.7	28.5	11.5	3.1	M16
SE1.30.A30.100.A.EX.4.61R.B	8.7	8.7	3.7	6.3	34.7	27.1	19.3	3.2	1.5	40.2	3	0.5	6.7	13.7	30.2	11.5	3.1	M16
SE1.30.A40.20.A.EX.4.60R.B	9.1	10.2	4.3	8.7	34.5	25.6	19.2	4.3	2	35.9	3	0	8.7	16.3	25.1	13	3.9	M16
SE1.30.A40.20.A.EX.4.60H.B	9.1	10.2	4.3	8.7	34.5	25.6	19.2	4.3	2	35.9	3	0	8.7	16.3	25.1	13	3.9	M16
SE1.30.A40.30.A.EX.4.60R.B	9.1	10.2	4.3	8.7	34.5	25.6	19.2	4.3	2	35.9	3	0	8.7	16.3	25.1	13	3.9	M16
SE1.30.A40.30.A.EX.4.60H.B	9.1	10.2	4.3	8.7	34.5	25.6	19.2	4.3	2	35.9	3	0	8.7	16.3	25.1	13	3.9	M16
SE1.30.A40.40.A.EX.4.61R.B	9.1	10.2	4.3	8.7	37.4	28.5	21.1	4.3	2	39.3	3	0	8.7	16.3	28.5	13.2	3.9	M16
SE1.30.A40.55.A.EX.4.61R.B	9.1	10.2	4.3	8.7	37.4	28.5	21.1	4.3	2	39.3	3	0	8.7	16.3	28.5	13.2	3.9	M16
SE1.30.A40.75.A.EX.4.61R.B	9.1	10.2	4.3	8.7	37.4	28.5	21.1	4.3	2	39.3	3	0	8.7	16.3	28.5	13.2	3.9	M16
SE1.30.A40.100.A.EX.4.61R.B	9.1	10.2	4.3	8.7	38.2	29.3	21.4	4.3	2	41.8	3	0	8.7	16.3	30.2	13.1	3.9	M16
SE1.40.A40.55.A.EX.4.61R.B	9.1	10.2	4.3	8.7	38.4	29.2	21.1	4.3	2	39.6	4	0	8.7	16.3	28.8	13.7	3.9	M16
SE1.40.A40.75.A.EX.4.61R.B	9.1	10.2	4.3	8.7	38.4	29.2	21.1	4.3	2	39.6	4	0	8.7	16.3	28.8	13.7	3.9	M16
SE1.40.A40.100.A.EX.4.61R.B	9.1	10.2	4.3	8.7	37.8	28.9	20.8	4.3	2	42.2	4	0	8.7	16.3	30.6	13.4	3.9	M16
SE1.40.A60.55.A.EX.4.61R.B	11.8	11.8	4.3	11	42.4	30	22	4.3	2	41.2	4	0	11	17.8	28.8	15.2	5.9	M16
SE1.40.A60.75.A.EX.4.61R.B	11.8	11.8	4.3	11	42.4	30	22	4.3	2	41.2	4	0	11	17.8	28.8	15.2	5.9	M16
SE1.40.A60.100.A.EX.4.61R.B	11.8	11.8	4.3	11	42.2	29.9	21.4	4.3	2	43.8	4	0	11	17.8	30.6	15	5.9	M16
SEV.25.A25.30.A.EX.2.60R	8.3	8.7	3.7	5.5	28.8	21.5	15.6	3.2	1.5	32.6	3	0	6.9	10.6	25.2	10	2.6	M16
SEV.25.A25.30.A.EX.2.60H	8.3	8.7	3.7	5.5	28.8	21.5	15.6	3.2	1.5	32.6	3	0	6.9	10.6	25.2	10	2.6	M16
SEV.25.A25.40.A.EX.2.60R	8.3	8.7	3.7	5.5	28.8	21.5	15.6	3.2	1.5	32.6	3	0	6.9	10.6	25.2	10	2.6	M16
SEV.25.A25.40.A.EX.2.60H	8.3	8.7	3.7	5.5	28.8	21.5	15.6	3.2	1.5	32.6	3	0	6.9	10.6	25.2	10	2.6	M16
SEV.25.A25.55.A.EX.2.61R	8.3	8.7	3.7	5.5	31.1	23.8	16.7	3.2	1.5	35.7	3	0	6.9	10.6	27.3	9.9	2.6	M16
SEV.25.A30.30.A.EX.2.60R	8.7	8.7	3.7	6.3	29.5	21.9	16	3.2	1.5	34	3	0.5	6.7	13.7	25.2	11.3	3.1	M16
SEV.25.A30.30.A.EX.2.60H	8.7	8.7	3.7	6.3	29.5	21.9	16	3.2	1.5	34	3	0.5	6.7	13.7	25.2	11.3	3.1	M16
SEV.25.A30.40.A.EX.2.60R	8.7	8.7	3.7	6.3	29.5	21.9	16	3.2	1.5	34	3	0.5	6.7	13.7	25.2	11.3	3.1	M16
SEV.25.A30.40.A.EX.2.60H	8.7	8.7	3.7	6.3	29.5	21.9	16	3.2	1.5	34	3	0.5	6.7	13.7	25.2	11.3	3.1	M16
SEV.25.A30.55.A.EX.2.61R	8.7	8.7	3.7	6.3	31.9	24.3	17.2	3.2	1.5	37	3	0.5	6.7	13.7	27.3	11.2	3.1	M16
SEV.30.A30.15.A.EX.4.60R	8.7	8.7	3.7	6.3	30	22.4	15.8	3.2	1.5	34.8	3	0.5	6.7	13.7	26.3	11.9	3.1	M16
SEV.30.A30.15.A.EX.4.60H	8.7	8.7	3.7	6.3	30	22.4	15.8	3.2	1.5	34.8	3	0.5	6.7	13.7	26.3	11.9	3.1	M16
SEV.30.A30.18.A.EX.4.60R	8.7	8.7	3.7	6.3	30	22.4	15.8	3.2	1.5	34.8	3	0.5	6.7	13.7	26.3	11.9	3.1	M16
SEV.30.A30.18.A.EX.4.60H	8.7	8.7	3.7	6.3	30	22.4	15.8	3.2	1.5	34.8	3	0.5	6.7	13.7	26.3	11.9	3.1	M16
SEV.30.A30.20.A.EX.4.60R	8.7	8.7	3.7	6.3	30	22.4	15.8	3.2	1.5	34.8	3	0.5	6.7	13.7	26.3	11.9	3.1	M16
SEV.30.A30.20.A.EX.4.60H	8.7	8.7	3.7	6.3	30	22.4	15.8	3.2	1.5	34.8	3	0.5	6.7	13.7	26.3	11.9	3.1	M16
SEV.30.A30.30.A.EX.4.60R	8.7	8.7	3.7	6.3	30	22.4	15.8	3.2	1.5	34.8	3	0.5	6.7	13.7	26.3	11.9	3.1	M16
SEV.30.A30.30.A.EX.4.60H	8.7	8.7	3.7	6.3	30	22.4	15.8	3.2	1.5	34.8	3	0.5	6.7	13.7	26.3	11.9	3.1	M16
SEV.30.A30.55.A.EX.4.61R	8.7	8.7	3.7	6.3	31.9	24.3	17.2	3.2	1.5	38.1	3	0.5	6.7	13.7	28.3	12.3	3.1	M16
SEV.30.A30.80.A.EX.2.61R	8.7	8.7	3.7	6.3	31.9	24.3	17.2	3.2	1.5	38.1	3	0.5	6.7	13.7	28.3	12.3	3.1	M16
SEV.30.A30.100.A.EX.2.61R	8.7	8.7	3.7	6.3	31.9	24.3	17.2	3.2	1.5	38.1	3	0.5	6.7	13.7	28.3	12.3	3.1	M16
SEV.30.A30.125.A.EX.2.61R	8.7	8.7	3.7	6.3	33.1	25.6	17.8	3.2	1.5	39.9	3	0.5	6.7	13.7	30.2	11.4	3.1	M16
SEV.30.A30.150.A.EX.2.61R	8.7	8.7	3.7	6.3	33.1	25.6	17.8	3.2	1.5	39.9	3	0.5	6.7	13.7	30.2	11.4	3.1	M16
SEV.30.A40.15.A.EX.4.60R	8.7	9.1	4.3	8.7	33.4	24.5	18	4.3	2	36.4	3	0	8.7	16.3	26.3	13.5	3.9	M16
SEV.30.A40.15.A.EX.4.60H	8.7	9.1	4.3	8.7	33.4	24.5	18	4.3	2	36.4	3	0	8.7	16.3	26.3	13.5	3.9	M16
SEV.30.A40.18.A.EX.4.60R	8.7	9.1	4.3	8.7	33.4	24.5	18	4.3	2	36.4	3	0	8.7	16.3	26.3	13.5	3.9	M16
SEV.30.A40.18.A.EX.4.60H	8.7	9.1	4.3	8.7	33.4	24.5	18	4.3	2	36.4	3	0	8.7	16.3	26.3	13.5	3.9	M16

Pump type	Z2	Z2A	Z3	Z4	Z6	Z7	Z8	Z9	Z10	Z11	Z12A	Z14	Z15	Z16	Z23	S3OPR	ZDN	ZM
SEV.30.A40.20.A.EX.4.60R	8.7	9.1	4.3	8.7	33.4	24.5	18	4.3	2	36.4	3	0	8.7	16.3	26.3	13.5	3.9	M16
SEV.30.A40.20.A.EX.4.60H	8.7	9.1	4.3	8.7	33.4	24.5	18	4.3	2	36.4	3	0	8.7	16.3	26.3	13.5	3.9	M16
SEV.30.A40.30.A.EX.4.60R	8.7	9.1	4.3	8.7	33.4	24.5	18	4.3	2	36.4	3	0	8.7	16.3	26.3	13.5	3.9	M16
SEV.30.A40.30.A.EX.4.60H	8.7	9.1	4.3	8.7	33.4	24.5	18	4.3	2	36.4	3	0	8.7	16.3	26.3	13.5	3.9	M16
SEV.30.A40.55.A.EX.4.61R	8.7	9.1	4.3	8.7	35.7	26.9	19.8	4.3	2	39.7	3	0	8.7	16.3	28.3	13.6	3.9	M16
SEV.30.A40.80.A.EX.2.61R	8.7	9.1	4.3	8.7	35.7	26.9	19.8	4.3	2	39.7	3	0	8.7	16.3	28.3	13.6	3.9	M16
SEV.30.A40.100.A.EX.2.61R	8.7	9.1	4.3	8.7	35.7	26.9	19.8	4.3	2	39.7	3	0	8.7	16.3	28.3	13.6	3.9	M16
SEV.30.A40.125.A.EX.2.61R	8.7	9.1	4.3	8.7	37	28.1	20.4	4.3	2	41.5	3	0	8.7	16.3	30.2	12.8	3.9	M16
SEV.30.A40.150.A.EX.2.61R	8.7	9.1	4.3	8.7	37	28.1	20.4	4.3	2	41.5	3	0	8.7	16.3	30.2	12.8	3.9	M16
SEV.40.A40.40.A.EX.4.61R	8.7	9.1	4.3	8.7	35.4	26.5	19.4	4.3	2	39.1	4	0	8.7	16.3	29	13.1	3.9	M16
SEV.40.A40.55.A.EX.4.61R	8.7	9.1	4.3	8.7	35.4	26.5	19.4	4.3	2	39.1	4	0	8.7	16.3	29	13.1	3.9	M16
SEV.40.A40.75.A.EX.4.61R	8.7	9.1	4.3	8.7	35.4	26.5	19.4	4.3	2	39.1	4	0	8.7	16.3	29	13.1	3.9	M16
SEV.40.A40.100.A.EX.4.61R	8.7	9.1	4.3	8.7	35.4	26.5	19.4	4.3	2	39.1	4	0	8.7	16.3	29	13.1	3.9	M16
SE1.20.A25.55.A.EX.2.61H.B	8.3	8.3	3.7	5.5	29.2	21.8	14.7	3.2	1.5	35.5	2	0	6.9	10.6	25.7	9.3	2.6	M16
SE1.20.A30.55.A.EX.2.61H.B	8.7	8.7	3.7	6.3	29.9	22.4	15.2	3.2	1.5	36.9	2	0.5	6.7	13.7	25.7	10.6	3.1	M16
SE1.30.A30.40.A.EX.4.61H.B	8.7	8.7	3.7	6.3	33.9	26.3	18.9	3.2	1.5	37.7	3	0.5	6.7	13.7	28.5	11.5	3.1	M16
SE1.30.A30.55.A.EX.4.61H.B	8.7	8.7	3.7	6.3	33.9	26.3	18.9	3.2	1.5	37.7	3	0.5	6.7	13.7	28.5	11.5	3.1	M16
SE1.30.A30.75.A.EX.4.61H.B	8.7	8.7	3.7	6.3	33.9	26.3	18.9	3.2	1.5	37.7	3	0.5	6.7	13.7	28.5	11.5	3.1	M16
SE1.30.A30.100.A.EX.4.61H.B	8.7	8.7	3.7	6.3	34.7	27.1	19.3	3.2	1.5	40.2	3	0.5	6.7	13.7	30.2	11.5	3.1	M16
SE1.30.A40.40.A.EX.4.61H.B	9.1	10.2	4.3	8.7	37.4	28.5	21.1	4.3	2	39.3	3	0	8.7	16.3	28.5	13.2	3.9	M16
SE1.30.A40.55.A.EX.4.61H.B	9.1	10.2	4.3	8.7	37.4	28.5	21.1	4.3	2	39.3	3	0	8.7	16.3	28.5	13.2	3.9	M16
SE1.30.A40.75.A.EX.4.61H.B	9.1	10.2	4.3	8.7	37.4	28.5	21.1	4.3	2	39.3	3	0	8.7	16.3	28.5	13.2	3.9	M16
SE1.30.A40.100.A.EX.4.61H.B	9.1	10.2	4.3	8.7	38.2	29.3	21.4	4.3	2	41.8	3	0	8.7	16.3	30.2	13.1	3.9	M16
SE1.40.A40.55.A.EX.4.61H.B	9.1	10.2	4.3	8.7	38.4	29.2	21.1	4.3	2	39.6	4	0	8.7	16.3	28.8	13.7	3.9	M16
SE1.40.A40.75.A.EX.4.61H.B	9.1	10.2	4.3	8.7	38.4	29.2	21.1	4.3	2	39.6	4	0	8.7	16.3	28.8	13.7	3.9	M16
SE1.40.A40.100.A.EX.4.61H.B	9.1	10.2	4.3	8.7	37.8	28.9	20.8	4.3	2	42.2	4	0	8.7	16.3	30.6	13.4	3.9	M16
SE1.40.A60.55.A.EX.4.61H.B	11.8	11.8	4.3	11	42.4	30	22	4.3	2	41.2	4	0	11	17.8	28.8	15.2	5.9	M16
SE1.40.A60.75.A.EX.4.61H.B	11.8	11.8	4.3	11	42.4	30	22	4.3	2	41.2	4	0	11	17.8	28.8	15.2	5.9	M16
SE1.40.A60.100.A.EX.4.61H.B	11.8	11.8	4.3	11	42.2	29.9	21.4	4.3	2	43.8	4	0	11	17.8	30.6	15	5.9	M16
SEV.25.A25.55.A.EX.2.61H	8.3	8.7	3.7	5.5	31.1	23.8	16.7	3.2	1.5	35.7	3	0	6.9	10.6	27.3	9.9	2.6	M16
SEV.25.A30.55.A.EX.2.61H	8.7	8.7	3.7	6.3	31.9	24.3	17.2	3.2	1.5	37	3	0.5	6.7	13.7	27.3	11.2	3.1	M16
SEV.30.A30.55.A.EX.4.61H	8.7	8.7	3.7	6.3	31.9	24.3	17.2	3.2	1.5	38.1	3	0.5	6.7	13.7	28.3	12.3	3.1	M16
SEV.30.A30.80.A.EX.2.61H	8.7	8.7	3.7	6.3	31.9	24.3	17.2	3.2	1.5	38.1	3	0.5	6.7	13.7	28.3	12.3	3.1	M16
SEV.30.A30.100.A.EX.2.61H	8.7	8.7	3.7	6.3	31.9	24.3	17.2	3.2	1.5	38.1	3	0.5	6.7	13.7	28.3	12.3	3.1	M16
SEV.30.A30.125.A.EX.2.61H	8.7	8.7	3.7	6.3	33.1	25.6	17.8	3.2	1.5	39.9	3	0.5	6.7	13.7	30.2	11.4	3.1	M16
SEV.30.A30.150.A.EX.2.61H	8.7	8.7	3.7	6.3	33.1	25.6	17.8	3.2	1.5	39.9	3	0.5	6.7	13.7	30.2	11.4	3.1	M16
SEV.30.A40.55.A.EX.4.61H	8.7	9.1	4.3	8.7	35.7	26.9	19.8	4.3	2	39.7	3	0	8.7	16.3	28.3	13.6	3.9	M16
SEV.30.A40.80.A.EX.2.61H	8.7	9.1	4.3	8.7	35.7	26.9	19.8	4.3	2	39.7	3	0	8.7	16.3	28.3	13.6	3.9	M16
SEV.30.A40.100.A.EX.2.61H	8.7	9.1	4.3	8.7	35.7	26.9	19.8	4.3	2	39.7	3	0	8.7	16.3	28.3	13.6	3.9	M16
SEV.30.A40.125.A.EX.2.61H	8.7	9.1	4.3	8.7	37	28.1	20.4	4.3	2	41.5	3	0	8.7	16.3	30.2	12.8	3.9	M16
SEV.30.A40.150.A.EX.2.61H	8.7	9.1	4.3	8.7	37	28.1	20.4	4.3	2	41.5	3	0	8.7	16.3	30.2	12.8	3.9	M16
SEV.40.A40.40.A.EX.4.61H	8.7	9.1	4.3	8.7	35.4	26.5	19.4	4.3	2	39.1	4	0	8.7	16.3	29	13.1	3.9	M16
SEV.40.A40.55.A.EX.4.61H	8.7	9.1	4.3	8.7	35.4	26.5	19.4	4.3	2	39.1	4	0	8.7	16.3	29	13.1	3.9	M16
SEV.40.A40.75.A.EX.4.61H	8.7	9.1	4.3	8.7	35.4	26.5	19.4	4.3	2	39.1	4	0	8.7	16.3	29	13.1	3.9	M16
SEV.40.A40.100.A.EX.4.61H	8.7	9.1	4.3	8.7	35.4	26.5	19.4	4.3	2	39.1	4	0	8.7	16.3	29	13.1	3.9	M16

Horizontal dry installation with brackets

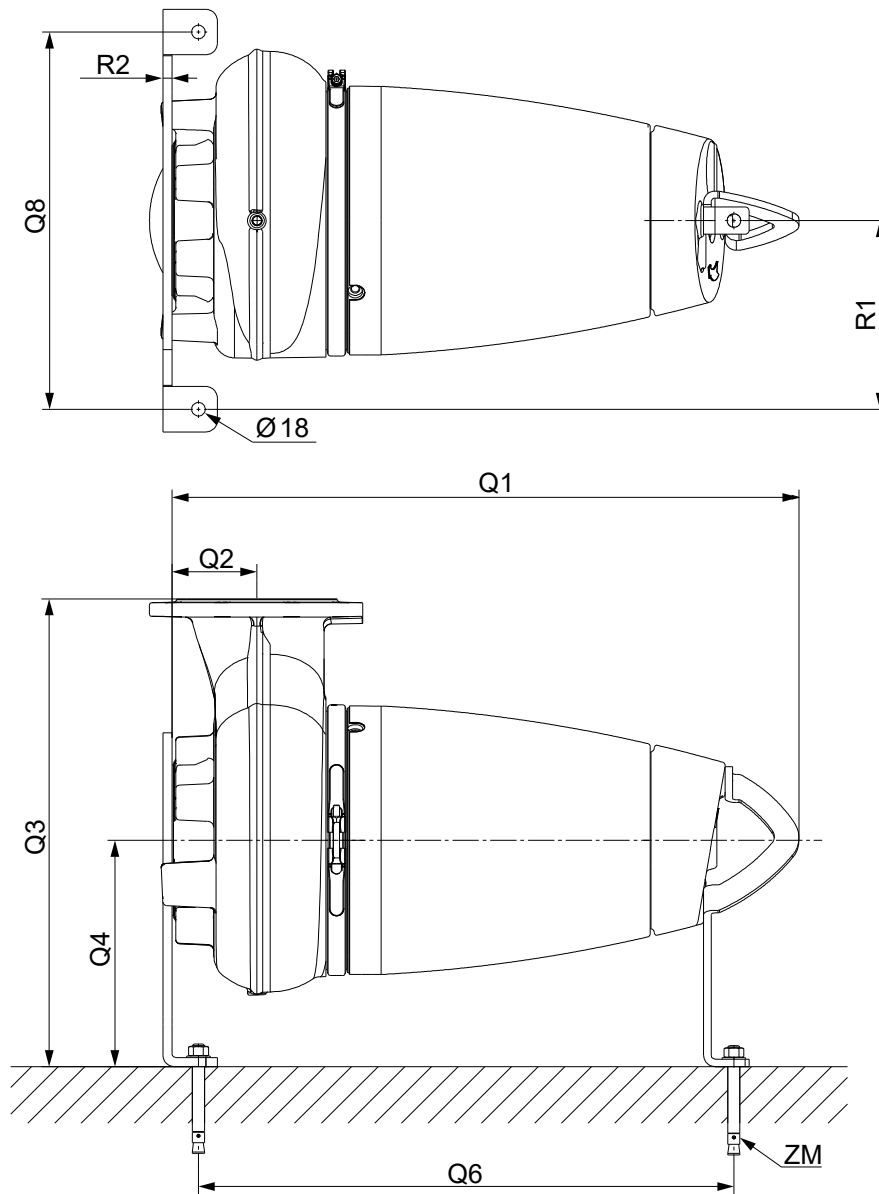

TM086246

Dimensions (inch)

Pump type	Foundation bolt size								
	ZM	Q1	Q2	Q3	Q4	Q6	Q8	R1	R2
SE1.20.A25.30.A.EX.2.60R.B	M16	26.9	2.7	16.4	7.9	22.9	13.8	6.9	0.4
SE1.20.A25.30.A.EX.2.60H.B	M16	26.9	2.7	16.4	7.9	22.9	13.8	6.9	0.4
SE1.20.A25.40.A.EX.2.60R.B	M16	26.9	2.7	16.4	7.9	22.9	13.8	6.9	0.4
SE1.20.A25.40.A.EX.2.60H.B	M16	26.9	2.7	16.4	7.9	22.9	13.8	6.9	0.4
SE1.20.A25.55.A.EX.2.61R.B	M16	30	2.8	16.8	7.9	24.9	13.8	6.9	0.4
SE1.20.A30.30.A.EX.2.60R.B	M16	26.9	2.7	16.4	7.9	22.9	13.8	6.9	0.4
SE1.20.A30.30.A.EX.2.60H.B	M16	26.9	2.7	16.4	7.9	22.9	13.8	6.9	0.4
SE1.20.A30.40.A.EX.2.60R.B	M16	26.9	2.7	16.4	7.9	22.9	13.8	6.9	0.4
SE1.20.A30.40.A.EX.2.60H.B	M16	26.9	2.7	16.4	7.9	22.9	13.8	6.9	0.4
SE1.20.A30.55.A.EX.2.61R.B	M16	30	2.8	16.8	7.9	24.9	13.8	6.9	0.4

Pump type	ZM	Q1	Q2	Q3	Q4	Q6	Q8	R1	R2
SE1.30.A30.20.A.EX.4.60R.B	M16	28.5	3.7	18.6	7.9	24.5	13.8	6.9	0.4
SE1.30.A30.20.A.EX.4.60H.B	M16	28.5	3.7	18.6	7.9	24.5	13.8	6.9	0.4
SE1.30.A30.30.A.EX.4.60R.B	M16	28.5	3.7	18.6	7.9	24.5	13.8	6.9	0.4
SE1.30.A30.30.A.EX.4.60H.B	M16	28.5	3.7	18.6	7.9	24.5	13.8	6.9	0.4
SE1.30.A30.40.A.EX.4.61R.B	M16	32.8	4.7	20.4	7.9	27.7	13.8	6.9	0.4
SE1.30.A30.55.A.EX.4.61R.B	M16	32.8	4.7	20.4	7.9	27.7	13.8	6.9	0.4
SE1.30.A30.75.A.EX.4.61R.B	M16	32.8	4.7	20.4	7.9	27.7	13.8	6.9	0.4
SE1.30.A30.100.A.EX.4.61R.B	M16	34.6	4.7	21.2	8.3	29.3	13.8	6.9	0.4
SE1.30.A40.20.A.EX.4.60R.B	M16	28.5	3.7	18.6	7.9	24.5	13.8	6.9	0.4
SE1.30.A40.20.A.EX.4.60H.B	M16	28.5	3.7	18.6	7.9	24.5	13.8	6.9	0.4
SE1.30.A40.30.A.EX.4.60R.B	M16	28.5	3.7	18.6	7.9	24.5	13.8	6.9	0.4
SE1.30.A40.30.A.EX.4.60H.B	M16	28.5	3.7	18.6	7.9	24.5	13.8	6.9	0.4
SE1.30.A40.40.A.EX.4.61R.B	M16	32.8	4.7	20.4	7.9	27.7	13.8	6.9	0.4
SE1.30.A40.55.A.EX.4.61R.B	M16	32.8	4.7	20.4	7.9	27.7	13.8	6.9	0.4
SE1.30.A40.75.A.EX.4.61R.B	M16	32.8	4.7	20.4	7.9	27.7	13.8	6.9	0.4
SE1.30.A40.100.A.EX.4.61R.B	M16	34.6	4.7	21.2	8.3	29.3	13.8	6.9	0.4
SE1.40.A40.55.A.EX.4.61R.B	M16	32.7	4.6	24.4	11.8	28	19.7	9.8	0.5
SE1.40.A40.75.A.EX.4.61R.B	M16	32.7	4.6	24.4	11.8	28	19.7	9.8	0.5
SE1.40.A40.100.A.EX.4.61R.B	M16	34.9	4.6	24.1	11.8	29.6	19.7	9.8	0.5
SE1.40.A60.55.A.EX.4.61R.B	M16	32.7	4.4	24.4	11.8	28	19.7	9.8	0.5
SE1.40.A60.75.A.EX.4.61R.B	M16	32.7	4.4	24.4	11.8	28	19.7	9.8	0.5
SE1.40.A60.100.A.EX.4.61R.B	M16	34.9	4.4	23.9	11.8	29.6	19.7	9.8	0.5
SEV.25.A25.30.A.EX.2.60R	M16	28.6	4.1	17.6	7.9	24.6	13.8	6.9	0.4
SEV.25.A25.30.A.EX.2.60H	M16	28.6	4.1	17.6	7.9	24.6	13.8	6.9	0.4
SEV.25.A25.40.A.EX.2.60R	M16	28.6	4.1	17.6	7.9	24.6	13.8	6.9	0.4
SEV.25.A25.40.A.EX.2.60H	M16	28.6	4.1	17.6	7.9	24.6	13.8	6.9	0.4
SEV.25.A25.55.A.EX.2.61R	M16	31.6	4.3	18.7	7.9	26.5	13.8	6.9	0.4
SEV.25.A30.30.A.EX.2.60R	M16	28.7	4.1	17.6	7.9	24.6	13.8	6.9	0.4
SEV.25.A30.30.A.EX.2.60H	M16	28.7	4.1	17.6	7.9	24.6	13.8	6.9	0.4
SEV.25.A30.40.A.EX.2.60R	M16	28.7	4.1	17.6	7.9	24.6	13.8	6.9	0.4
SEV.25.A30.40.A.EX.2.60H	M16	28.7	4.1	17.6	7.9	24.6	13.8	6.9	0.4
SEV.25.A30.55.A.EX.2.61R	M16	31.6	4.3	18.7	7.9	26.5	13.8	6.9	0.4
SEV.30.A30.15.A.EX.4.60R	M16	29.7	4.4	17.4	7.9	25.6	13.8	6.9	0.4
SEV.30.A30.15.A.EX.4.60H	M16	29.7	4.4	17.4	7.9	25.6	13.8	6.9	0.4
SEV.30.A30.18.A.EX.4.60R	M16	29.7	4.4	17.4	7.9	25.6	13.8	6.9	0.4
SEV.30.A30.18.A.EX.4.60H	M16	29.7	4.4	17.4	7.9	25.6	13.8	6.9	0.4
SEV.30.A30.20.A.EX.4.60R	M16	29.7	4.4	17.4	7.9	25.6	13.8	6.9	0.4
SEV.30.A30.20.A.EX.4.60H	M16	29.7	4.4	17.4	7.9	25.6	13.8	6.9	0.4
SEV.30.A30.30.A.EX.4.60R	M16	29.7	4.4	17.4	7.9	25.6	13.8	6.9	0.4
SEV.30.A30.30.A.EX.4.60H	M16	29.7	4.4	17.4	7.9	25.6	13.8	6.9	0.4
SEV.30.A30.55.A.EX.4.61R	M16	32.6	4.2	18.7	7.9	27.5	13.8	6.9	0.4
SEV.30.A30.80.A.EX.2.61R	M16	32.6	4.2	18.7	7.9	27.5	13.8	6.9	0.4
SEV.30.A30.100.A.EX.2.61R	M16	32.6	4.2	18.7	7.9	27.5	13.8	6.9	0.4
SEV.30.A30.125.A.EX.2.61R	M16	34.5	4.9	19.8	8.3	29.2	13.8	6.9	0.4
SEV.30.A30.150.A.EX.2.61R	M16	34.5	4.9	19.8	8.3	29.2	13.8	6.9	0.4
SEV.30.A40.15.A.EX.4.60R	M16	29.7	4.4	17.4	7.9	25.6	13.8	6.9	0.4
SEV.30.A40.15.A.EX.4.60H	M16	29.7	4.4	17.4	7.9	25.6	13.8	6.9	0.4
SEV.30.A40.18.A.EX.4.60R	M16	29.7	4.4	17.4	7.9	25.6	13.8	6.9	0.4
SEV.30.A40.18.A.EX.4.60H	M16	29.7	4.4	17.4	7.9	25.6	13.8	6.9	0.4
SEV.30.A40.20.A.EX.4.60R	M16	29.7	4.4	17.4	7.9	25.6	13.8	6.9	0.4
SEV.30.A40.20.A.EX.4.60H	M16	29.7	4.4	17.4	7.9	25.6	13.8	6.9	0.4

Pump type	ZM	Q1	Q2	Q3	Q4	Q6	Q8	R1	R2
SEV.30.A40.30.A.EX.4.60R	M16	29.7	4.4	17.4	7.9	25.6	13.8	6.9	0.4
SEV.30.A40.30.A.EX.4.60H	M16	29.7	4.4	17.4	7.9	25.6	13.8	6.9	0.4
SEV.30.A40.55.A.EX.4.61R	M16	32.6	4.2	19.1	7.9	27.5	13.8	6.9	0.4
SEV.30.A40.80.A.EX.2.61R	M16	32.6	4.2	19.1	7.9	27.5	13.8	6.9	0.4
SEV.30.A40.100.A.EX.2.61R	M16	32.6	4.2	19.1	7.9	27.5	13.8	6.9	0.4
SEV.30.A40.125.A.EX.2.61R	M16	34.5	4.9	20.2	8.3	29.2	13.8	6.9	0.4
SEV.30.A40.150.A.EX.2.61R	M16	34.5	4.9	20.2	8.3	29.2	13.8	6.9	0.4
SEV.40.A40.40.A.EX.4.61R	M16	33.2	5.4	18.8	7.9	28.1	13.8	6.9	0.4
SEV.40.A40.55.A.EX.4.61R	M16	33.2	5.4	18.8	7.9	28.1	13.8	6.9	0.4
SEV.40.A40.75.A.EX.4.61R	M16	33.2	5.4	18.8	7.9	28.1	13.8	6.9	0.4
SE1.20.A25.55.A.EX.2.61H.B	M16	30	2.8	16.8	7.9	24.9	13.8	6.9	0.4
SE1.20.A30.55.A.EX.2.61H.B	M16	30	2.8	16.8	7.9	24.9	13.8	6.9	0.4
SE1.30.A30.40.A.EX.4.61H.B	M16	32.8	4.7	20.4	7.9	27.7	13.8	6.9	0.4
SE1.30.A30.55.A.EX.4.61H.B	M16	32.8	4.7	20.4	7.9	27.7	13.8	6.9	0.4
SE1.30.A30.75.A.EX.4.61H.B	M16	32.8	4.7	20.4	7.9	27.7	13.8	6.9	0.4
SE1.30.A30.100.A.EX.4.61H.B	M16	34.6	4.7	21.2	8.3	29.3	13.8	6.9	0.4
SE1.30.A40.40.A.EX.4.61H.B	M16	32.8	4.7	20.4	7.9	27.7	13.8	6.9	0.4
SE1.30.A40.55.A.EX.4.61H.B	M16	32.8	4.7	20.4	7.9	27.7	13.8	6.9	0.4
SE1.30.A40.75.A.EX.4.61H.B	M16	32.8	4.7	20.4	7.9	27.7	13.8	6.9	0.4
SE1.30.A40.100.A.EX.4.61H.B	M16	34.6	4.7	21.2	8.3	29.3	13.8	6.9	0.4
SE1.40.A40.55.A.EX.4.61H.B	M16	32.7	4.6	24.4	11.8	28	19.7	9.8	0.5
SE1.40.A40.75.A.EX.4.61H.B	M16	32.7	4.6	24.4	11.8	28	19.7	9.8	0.5
SE1.40.A40.100.A.EX.4.61H.B	M16	34.9	4.6	24.1	11.8	29.6	19.7	9.8	0.5
SE1.40.A60.55.A.EX.4.61H.B	M16	32.7	4.4	24.4	11.8	28	19.7	9.8	0.5
SE1.40.A60.75.A.EX.4.61H.B	M16	32.7	4.4	24.4	11.8	28	19.7	9.8	0.5
SE1.40.A60.100.A.EX.4.61H.B	M16	34.9	4.4	23.9	11.8	29.6	19.7	9.8	0.5
SEV.25.A25.55.A.EX.2.61H	M16	31.6	4.3	18.7	7.9	26.5	13.8	6.9	0.4
SEV.25.A30.55.A.EX.2.61H	M16	31.6	4.3	18.7	7.9	26.5	13.8	6.9	0.4
SEV.30.A30.55.A.EX.4.61H	M16	32.6	4.2	18.7	7.9	27.5	13.8	6.9	0.4
SEV.30.A30.80.A.EX.2.61H	M16	32.6	4.2	18.7	7.9	27.5	13.8	6.9	0.4
SEV.30.A30.100.A.EX.2.61H	M16	32.6	4.2	18.7	7.9	27.5	13.8	6.9	0.4
SEV.30.A30.125.A.EX.2.61H	M16	34.5	4.9	19.8	8.3	29.2	13.8	6.9	0.4
SEV.30.A30.150.A.EX.2.61H	M16	34.5	4.9	19.8	8.3	29.2	13.8	6.9	0.4
SEV.30.A40.55.A.EX.4.61H	M16	32.6	4.2	19.1	7.9	27.5	13.8	6.9	0.4
SEV.30.A40.80.A.EX.2.61H	M16	32.6	4.2	19.1	7.9	27.5	13.8	6.9	0.4
SEV.30.A40.100.A.EX.2.61H	M16	32.6	4.2	19.1	7.9	27.5	13.8	6.9	0.4
SEV.30.A40.125.A.EX.2.61H	M16	34.5	4.9	20.2	8.3	29.2	13.8	6.9	0.4
SEV.30.A40.150.A.EX.2.61H	M16	34.5	4.9	20.2	8.3	29.2	13.8	6.9	0.4
SEV.40.A40.40.A.EX.4.61H	M16	33.2	5.4	18.8	7.9	28.1	13.8	6.9	0.4
SEV.40.A40.55.A.EX.4.61H	M16	33.2	5.4	18.8	7.9	28.1	13.8	6.9	0.4
SEV.40.A40.75.A.EX.4.61H	M16	33.2	5.4	18.8	7.9	28.1	13.8	6.9	0.4

Weights

Pump type	Weight (lbs)
SE1.20.A25.30.A.EX.2.60H.B	231.8
SE1.20.A25.30.A.EX.2.60R.B	229.9
SE1.20.A25.40.A.EX.2.60H.B	241.1
SE1.20.A25.40.A.EX.2.60R.B	241
SE1.20.A25.55.A.EX.2.61R.B	344.4
SE1.20.A30.30.A.EX.2.60H.B	233.8
SE1.20.A30.30.A.EX.2.60R.B	233
SE1.20.A30.40.A.EX.2.60H.B	242.6
SE1.20.A30.40.A.EX.2.60R.B	242.6
SE1.20.A30.55.A.EX.2.61R.B	349.8
SE1.30.A30.100.A.EX.4.61R.B	539.1
SE1.30.A30.20.A.EX.4.60H.B	259.8
SE1.30.A30.20.A.EX.4.60R.B	259.8
SE1.30.A30.30.A.EX.4.60H.B	275.8
SE1.30.A30.30.A.EX.4.60R.B	276.5
SE1.30.A30.40.A.EX.4.61R.B	399
SE1.30.A30.55.A.EX.4.61R.B	408.6
SE1.30.A30.75.A.EX.4.61R.B	414
SE1.30.A40.100.A.EX.4.61R.B	541.6
SE1.30.A40.20.A.EX.4.60H.B	262.6
SE1.30.A40.20.A.EX.4.60R.B	262.9
SE1.30.A40.30.A.EX.4.60H.B	278.9
SE1.30.A40.30.A.EX.4.60R.B	279.6
SE1.30.A40.40.A.EX.4.61R.B	401.5
SE1.30.A40.55.A.EX.4.61R.B	373.1
SE1.30.A40.75.A.EX.4.61R.B	422
SE1.40.A40.100.A.EX.4.61R.B	544.5
SE1.40.A40.55.A.EX.4.61R.B	422
SE1.40.A40.75.A.EX.4.61R.B	437.1
SE1.40.A60.100.A.EX.4.61R.B	557.8
SE1.40.A60.55.A.EX.4.61R.B	445.4
SE1.40.A60.75.A.EX.4.61R.B	445.9
SEV.25.A25.30.A.EX.2.60H	235.4
SEV.25.A25.30.A.EX.2.60R	235.4
SEV.25.A25.40.A.EX.2.60H	246
SEV.25.A25.40.A.EX.2.60R	245.5
SEV.25.A25.55.A.EX.2.61R	346.7
SEV.25.A30.30.A.EX.2.60H	238.4
SEV.25.A30.30.A.EX.2.60R	237.3
SEV.25.A30.40.A.EX.2.60H	247.9
SEV.25.A30.40.A.EX.2.60R	247.9
SEV.25.A30.55.A.EX.2.61R	347.6
SEV.30.A30.100.A.EX.2.61R	378.6
SEV.30.A30.125.A.EX.2.61R	505.4
SEV.30.A30.15.A.EX.4.60H	251.7
SEV.30.A30.15.A.EX.4.60R	251.7
SEV.30.A30.150.A.EX.2.61R	506.2
SEV.30.A30.18.A.EX.4.60H	256.3
SEV.30.A30.18.A.EX.4.60R	256.2

Pump type	Weight (lbs)
SEV.30.A30.20.A.EX.4.60H	258.8
SEV.30.A30.20.A.EX.4.60R	258.2
SEV.30.A30.30.A.EX.4.60H	271.4
SEV.30.A30.30.A.EX.4.60R	270.6
SEV.30.A30.55.A.EX.4.61R	383.6
SEV.30.A30.80.A.EX.2.61R	376.8
SEV.30.A40.100.A.EX.2.61R	381.6
SEV.30.A40.125.A.EX.2.61R	503.2
SEV.30.A40.15.A.EX.4.60H	247.7
SEV.30.A40.15.A.EX.4.60R	246.5
SEV.30.A40.150.A.EX.2.61R	505.6
SEV.30.A40.18.A.EX.4.60H	252.9
SEV.30.A40.18.A.EX.4.60R	252.4
SEV.30.A40.20.A.EX.4.60H	253.3
SEV.30.A40.20.A.EX.4.60R	252.9
SEV.30.A40.30.A.EX.4.60H	267.3
SEV.30.A40.30.A.EX.4.60R	267.3
SEV.30.A40.55.A.EX.4.61R	377.5
SEV.30.A40.80.A.EX.2.61R	381.3
SEV.40.A40.100.A.EX.4.61R	499
SEV.40.A40.40.A.EX.4.61R	364.4
SEV.40.A40.55.A.EX.4.61R	372.3
SEV.40.A40.75.A.EX.4.61R	386.3

Flange forces

The flange forces and moments are according to EN ISO 5199.

Forces can be found for both horizontal and vertical installations in Table B.3 in EN ISO 5199 by selecting the correct flange dimension. Forces cannot be used directly for end-suction wastewater pumps without using a coefficient which can be found in Table B.5 in EN ISO 5199 by selecting the correct pump family.

For Grundfos wastewater pumps, the pump families and coefficients are stated below.

- Horizontally installed pumps
Pump family A4 = Coefficient 0.35
- Vertically installed pumps
Pump family 10A = Coefficient 0.30

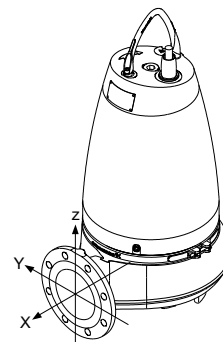

TM080160

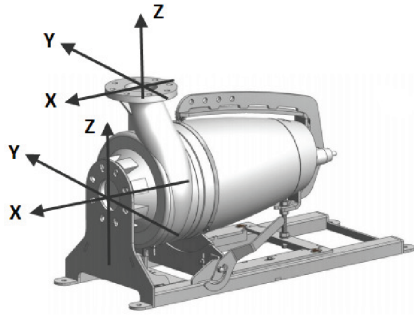

TM080161

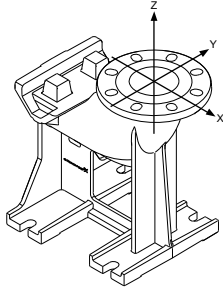

TM064901

12. Grundfos Product Center

It is an online search and sizing tool to help you make the right choice.

From the international view, you can select your specific country to view the product range available to you.

International view: <https://product-selection.grundfos.com>

All the information you need in one place

Performance curves, technical specifications, pictures, dimensional drawings, motor curves, wiring diagrams, spare parts, service kits, 3D drawings, documents, system parts. The Product Center displays any recent and saved items - including complete projects - right on the main page.

Downloads

On the product pages, you can download installation and operating instructions, data booklets, service instructions, etc., in PDF format.

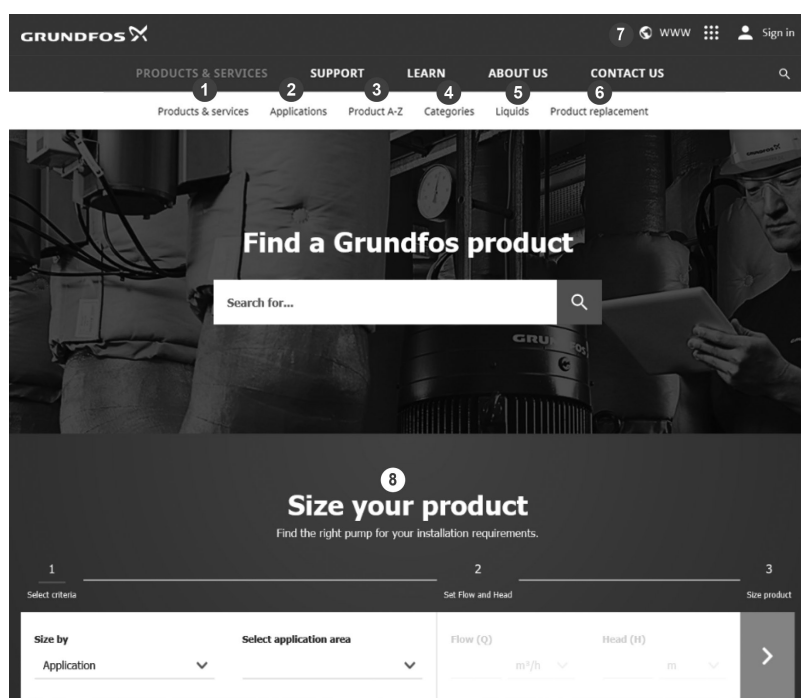

When you select your country, you see the menus below. Note that some menus may not be available depending on the country.

Example: <https://product-selection.grundfos.com/us>

Pos.	Description
1	Products & services enables you to find products and documents by typing a product number or name into the search field.
2	Applications enables you to choose an application to see how Grundfos can help you design and optimize your system.
3	Products A-Z enables you to look through a list of all the Grundfos products.
4	Categories enables you to look for a product category.
5	Liquids enables you to find pumps designed for aggressive, flammable or other special liquids.
6	Product replacement enables you to find a suitable replacement.
7	WWW enables you to select the country, which changes the language, the available product range and the structure of the website.
8	Sizing enables you to size a product based on your application and operating conditions.

Grundfos GO

Mobile solution for professionals on the GO!

Grundfos GO is the mobile tool box for professional users on the go. It is the most comprehensive platform for mobile pump control and pump selection including sizing,

replacement and documentation. It offers intuitive, handheld assistance and access to Grundfos online tools, and it saves valuable time for reporting and data collection.



TM0061109

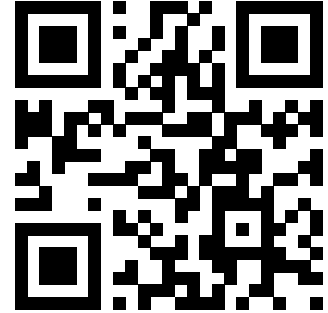

TM058869

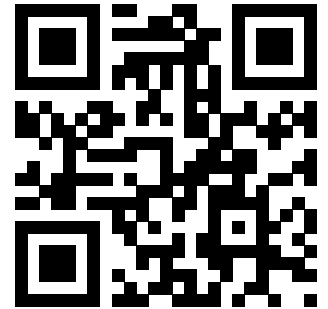

TM058868

93126063 03.2024

ECM: 1388406

GRUNDFOS Holding A/S
Poul Due Jensens Vej 7
DK-8850 Bjerringbro
Tel: +45 87 50 14 00
www.grundfos.com

GRUNDFOS 