

C41 • C51 • C61 Series Centrifugal Pumps



- Capacities to 100 GPM
- Heads to 140 Feet
- All Investment Cast Stainless Steel Construction



Questions? Call **1-800-810-1053**



C41 • C51 • C61 Series Centrifugal Pumps

MTH C Series

Close-coupled centrifugal pumps from MTH provide economical performance for 5 to 100 GPM applications requiring heads to 140 feet. By combining the latest concepts in pump design with precision manufacturing, the C Series pumps deliver excellent efficiency and low NPSH requirements. Efficient manufacturing processes and highly optimized mechanical designs control costs. Maintenance costs are kept to a minimum by combining a highly serviceable design with quality components to provide a long service life.

Impeller Design

C Series semi-open impellers allow the pump to pass small solids and fibrous material while close running tolerances maintain efficiency and performance. Impellers are pre-trimmed to be non-overloading to the pump and motor size indicated.

NPSH Requirements

C Series centrifugal pumps meet low net positive suction head requirements (NPSHR) without sacrificing efficiency. This is achieved by low fluid inlet velocity and gentle acceleration to peripheral velocities.

Mechanical Seal Box

The large seal chamber provides a wide fluid passage area for maximum cooling of the seal faces and allows debris and gases to be flushed away.

Axial Balance System

The C Series pumps utilize a thrust balancing system which combines the advantages of both static and dynamic balancing techniques to reduce axial thrust and provide longer bearing life.

D3 Motors

Similar to the T31 Series, the C Series takes advantage of our custom manufactured dual face D3 motors that incorporate a 304 stainless steel shaft and heavy-duty bearing. The stainless steel shaft eliminates the necessity of a shaft sleeve, thereby reducing the parts count and simplifying maintenance and servicing procedures. All D3 motors also feature a two-pole 50/60Hz rating, as well as CE Mark approval useful for OEM's with worldwide customers. The three-phase versions of the D3 motors

feature a compact TEFC enclosure and a range from 1/3 to 3HP. The single phase D3 motors have an ODP enclosure and a range from 1/3 to 2HP.

Adjustable Casing

C Series pump casings are axially adjustable allowing the use of custom impellers for OEM applications and to allow restoration of performance by closing up the internal clearances that develop over the course of a unit's extended service life.

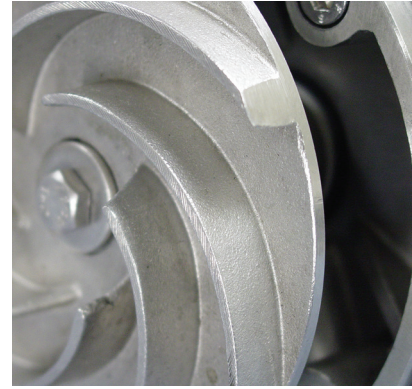

Optional Features

Construction Materials

All major components are 316 investment cast stainless steel. Seal elastomer and "O" ring gaskets of Buna, EPR, and Viton are available. Carbon vs. ceramic seal/seat materials are standard with graphite loaded silicon carbide seal/seat as an option.

Vertical Flange Mounting

MTH vertical flange mounted centrifugal pumps offer the best materials available to create the longest lasting pumps for your boiler feed needs. Our flange mounted pumps feature high grade investment cast stainless steel in a compact size. This unique design is adaptable to many fits and can easily replace your existing condensate return

pump with very little modification to your existing system. These pumps are made to fit standard vertical flange mount tanks.

56C-Face Adapter

When it is necessary to use special configuration motors or special enclosure motors for the C Series pumps, the 56 C-face adapter allows a small footprint and better alignment than the optional pedestal mounted configuration by maintaining a close coupled configuration and only adding 3 inches to the overall length of the pump and motor.

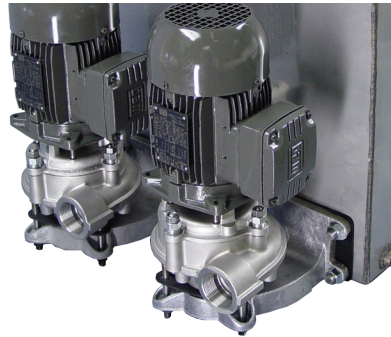

STANDARD MATERIALS

PART	MATERIALS
Motor Bracket	Stainless Steel
Casing	Stainless Steel
Impeller	Stainless Steel
Motor Shaft	Stainless Steel
"O" Rings	Viton A
Seals	Carbon/Viton
Seats	Ceramic/Viton

LIMITATIONS

Discharge Pressure	200 PSI
Seal Pressure* (Max)	145 PSI
Suction Pressure (Min)	26" Hg Vac.
Speed** (Max.)	5500 RPM
Temperature	
Standard Construction	-20° F
Ceramic Seal Seat - Water	+230° F
Graph. Loaded Silicon Carbide Seal Seat & Seal Flush	+250° F
Horsepower	
D3 - 3Ø	3 HP
D3 - 1Ø	2 HP



WARNING:
CANCER AND REPRODUCTIVE HARM
WWW.P65WARNINGS.CA.GOV

* Consult factory for pressures over 145 psi

** With variable frequency drive @ 90Hz

C41 • C51 • C61 SERIES

Performance Curves

C41 • C51 • C61 SERIES

3450 RPM

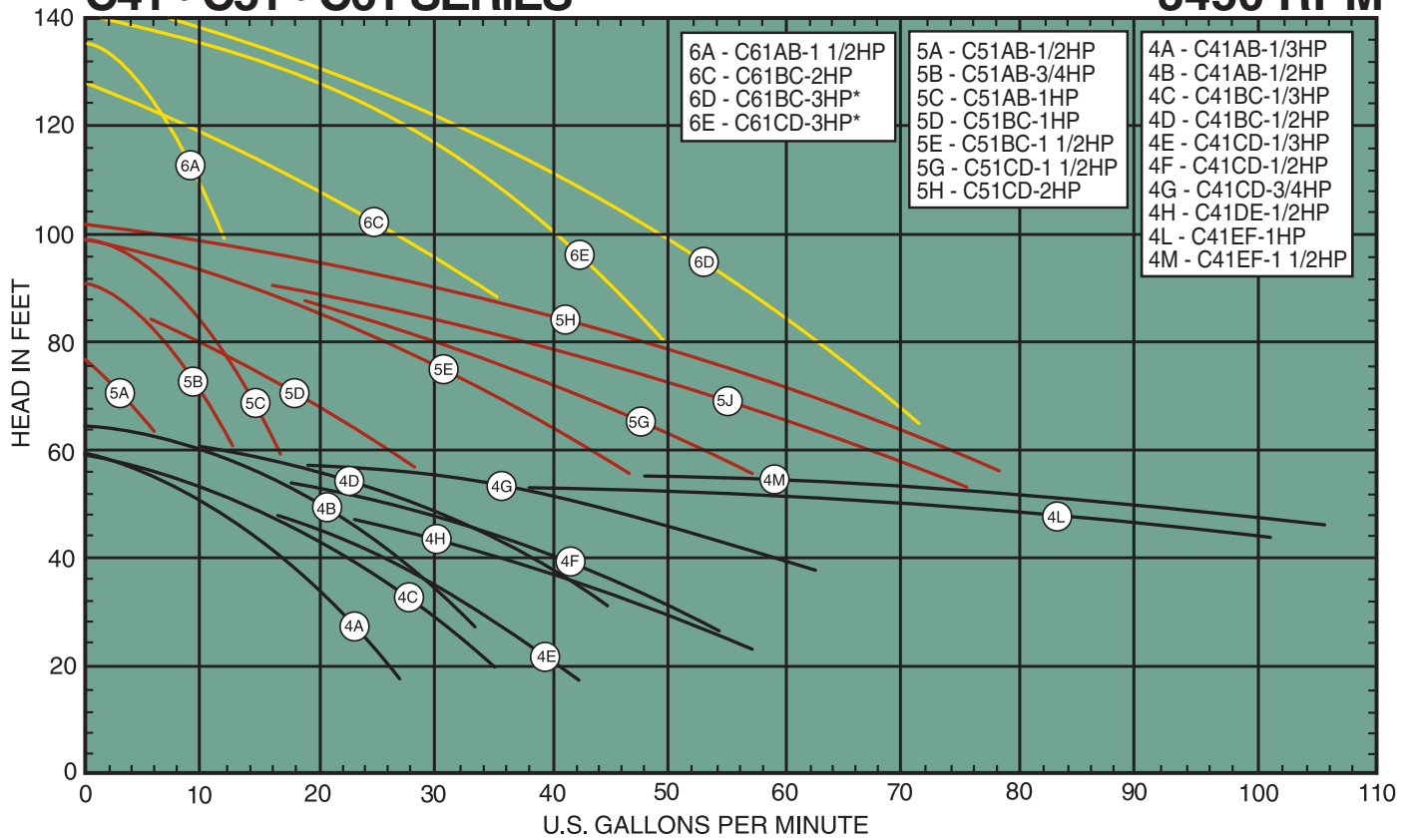

C41 • C51 • C61 SERIES

2880 RPM

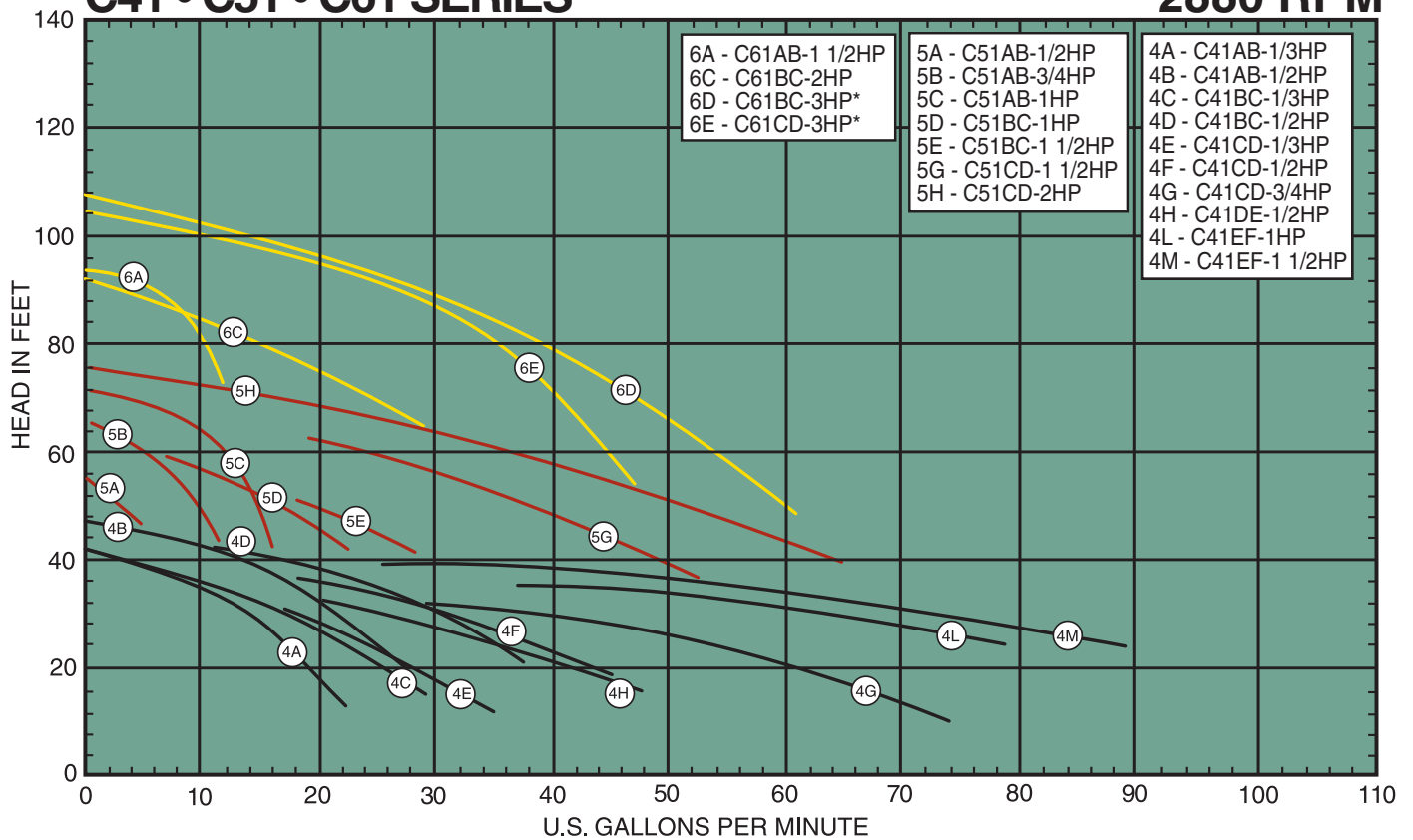

*#HP motors are available in 3 phase only

Dimensions (Three Phase)

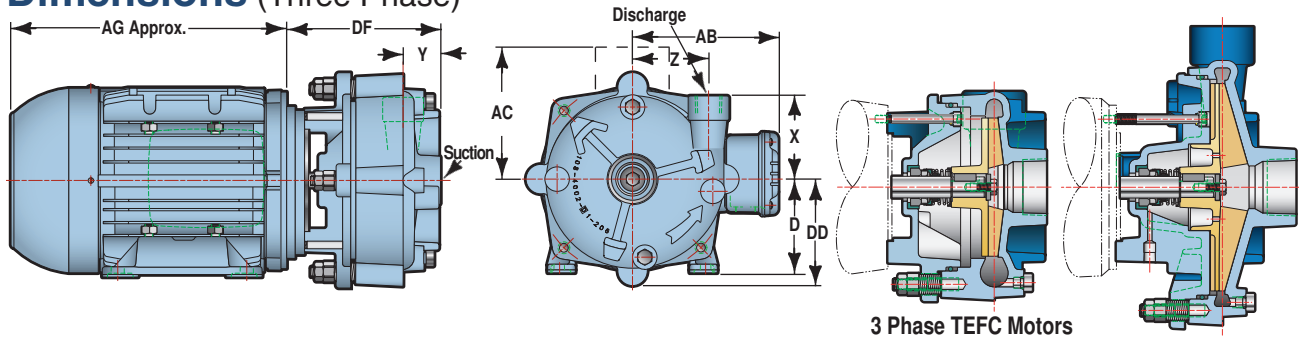

Pump Size				71 Frame (1/3HP - 3/4HP)			80 Frame (1HP - 1 1/2HP)			90 Frame (2HP - 3HP)							
Model	Disch.	Suction	Imp. Ø	DD	DF	X	Y	Z	AB	D	AG	AB	D	AG	AC	D	AG
C41AB	1/2	3/4	4	3 1/4	4 3/16	2 9/16	1 3/16	2 5/16	5	2 13/16	8 13/16	---	---	---	---	---	---
C41BC	3/4	1	4	3 1/4	4 3/8	2 5/8	1 5/16	2 7/16	5	2 13/16	8 13/16	---	---	---	---	---	---
C41CD	1	1 1/4	4	3 1/4	4 9/16	2 3/4	1 1/2	2 9/16	5	2 13/16	8 13/16	---	---	---	---	---	---
C41DE	1 1/4	1 1/2	4	3 7/16	4 13/16	2 15/16	1 3/4	2 11/16	5	2 13/16	8 13/16	5 3/8	3 1/8	9 7/16	---	---	---
C41EF	1 1/2	2	4	3 5/16	5 3/16	2 15/16	2 1/16	2 13/16	5	2 13/16	8 13/16	5 3/8	3 1/8	9 7/16	---	---	---
C51AB	1/2	3/4	5	3 1/2	4 3/8	3 1/16	1 5/16	2 3/4	5	2 13/16	8 13/16	5 3/8	3 1/8	9 7/16	---	---	---
C51BC	3/4	1	5	3 1/2	4 7/16	3 1/16	1 5/16	2 13/16	---	---	---	5 3/8	3 1/8	9 7/16	---	---	---
C51CD	1	1 1/4	5	3 5/8	4 9/16	3 3/16	1 1/2	3	---	---	---	5 3/8	3 1/8	9 7/16	5 7/8	3 9/16	11 5/16
C61AB	1/2	3/4	6	3 15/16	4 5/8	3 7/16	1 1/2	3 5/16	---	---	---	5 3/8	3 1/8	9 7/16	---	---	---
C61BC	3/4	1	6	3 15/16	4 7/16	3 15/16	1 5/16	3 1/4	---	---	---	5 3/8	3 1/8	9 7/16	5 7/8	3 9/16	11 5/16
C61CD	1	1 1/4	6	3 15/16	5 3/16	4 5/8	2 1/8	3 3/16	---	---	---	---	---	---	5 7/8	3 9/16	11 5/16

All units in inches

Dimensions (Single Phase)

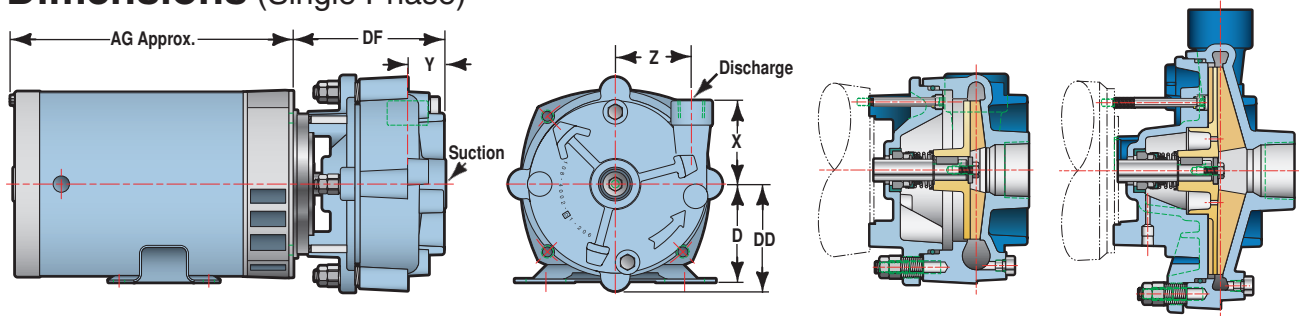

Pump Size				48 Frame (1/3 - 1HP)			56 Frame (1 1/2 - 2HP)					
Model	Disch.	Suction	Imp. Ø	DD	DF	X	Y	Z	D	AG(Max.)	D	AG
C41AB	1/2	3/4	4	3 1/4	4 3/16	2 9/16	1 3/16	2 5/16	3	10 1/4	---	---
C41BC	3/4	1	4	3 1/4	4 3/8	2 5/8	1 5/16	2 7/16	3	10 1/4	---	---
C41CD	1	1 1/4	4	3 1/4	4 9/16	2 3/4	1 1/2	2 9/16	3	10 13/16	---	---
C41DE	1 1/4	1 1/2	4	3 7/16	4 13/16	2 15/16	1 3/4	2 11/16	3	10 13/16	---	---
C41EF	1 1/2	2	4	3 5/16	5 3/16	2 15/16	2 1/16	2 13/16	3	11 5/16	---	---
C51AB	1/2	3/4	5	3 1/2	4 3/8	3 1/16	1 5/16	2 3/4	3	10 13/16	---	---
C51BC	3/4	1	5	3 1/2	4 7/16	3 1/16	1 5/16	2 13/16	3	11 5/16	---	---
C51CD	1	1 1/4	5	3 5/8	4 9/16	3 3/16	1 1/2	3	3	11 5/16	3 1/2	10 15/16
C61AB	1/2	3/4	6	3 15/16	4 5/8	3 7/16	1 1/2	3 5/16	3	11 5/16	---	---
C61BC	3/4	1	6	3 15/16	4 7/16	3 15/16	1 5/16	3 1/4	3	11 5/16	3 1/2	10 15/16

All units in inches



ISO Registered Company



MTH PUMPS

401 West Main Street • Plano, IL 60545-1436
 Phone: 630-552-4115 • Fax: 630-552-3688
 Email: SALES@MTHPUMPS.COM
 http://WWW.MTHPUMPS.COM