

EXPLODED VIEW & PARTS LISTING

Model: G15S[x]
Stainless Steel Series

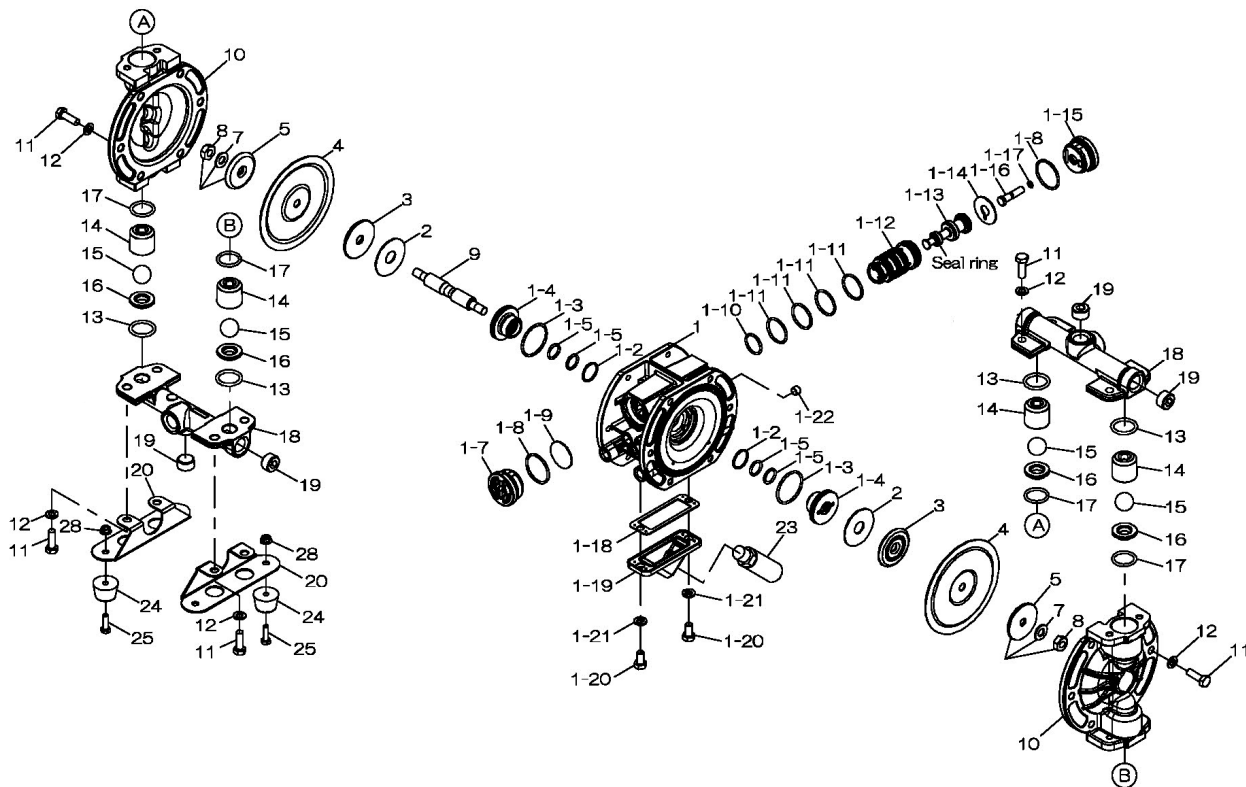

Air Operated Double Diaphragm Pump

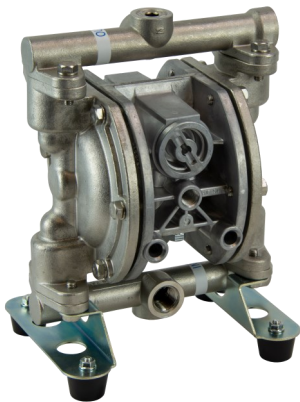

Air Operated Double Diaphragm Pump

	G15SH	G15SN	G15SS			
	854736	854734	854737			
REF. NO.	PART NO.	PART NO.	PART NO.	DESCRIPTION	QTY.	REORDER
1	805130	805130	805130	BODY ASSY NPT	1	
1-1	717082	717082	717082	BODY NPT	1	
1-2	684725	684725	684725	O-RING	2	
1-3	686733	686733	686733	O-RING	2	
1-4	773279	773279	773279	GUIDE BUSH	2	
1-5	640015	640015	640015	O-RING	4	
1-7	716917	716917	716917	CAP A	1	
1-8	686734	686734	686734	O-RING	2	
1-9	773280	773280	773280	CUSHION	1	
1-10	685276	685276	685276	O-RING	1	
1-11	686029	686029	686029	O-RING	4	
1-12	716950	716950	716950	SLEEVE	1	
1-13	805131	805131	805131	SPOOL ASSY	1	
1-14	773281	773281	773281	CUSHION	1	
1-15	716918	716918	716918	CAP B	1	
1-16	717035	717035	717035	RESET BUTTON	1	
1-17	640002	640002	640002	O-RING	1	
1-18	773283	773283	773283	GASKET	1	
1-19	717083	717083	717083	COVER NPT	1	
1-20	611145	611145	611145	BOLT	2	
1-21	631916	631916	631916	WAVE WASHER M8	2	
1-22	634360	634360	634360	PLUG 1/8"	1	
2	773278	773278	773278	CUSHION	2	
3	716923	716923	716923	CENTER DISC	2	
4	773316	773277	773315	DIAPHRAGM	2	
5	717215	717215	717215	CENTER DISK	2	
9	717100	717100	717100	CENTER ROD	1	
10	716927	716927	716927	OUT CHAMBER	2	
11	621149	621149	621149	BOLT HET FT	20	
12	631936	631936	631936	WAVE WASHER M8	20	
13	640025	640025	684114	O-RING	4	
14	717208	717208	717208	VALVE STOPPER	4	
15	773374	773422	773424	BALL	4	
16	717210	717210	717210	VALVE SEAT	4	
17	640130	640130	684113	O-RING	4	
18	716929	716929	716929	MANIFOLD NPT	2	
19	686789	686789	686789	PLUG 1/2" NPT	4	
20	717186	717186	717186	BASE	2	
23	682520	682520	682520	SILENCER NPT 3/8	1	
24	771123	771123	771123	FOOT RUBBER	4	
25	611101	611101	611101	BOLT	4	
28	682817	682817	682817	NUT W/ FLANGE	4	
KIT	KG15-MH	KG15-MN	KG15-MS	LIQUID END KIT		
KIT		KG15-AM-M		AIR MOTOR KIT		

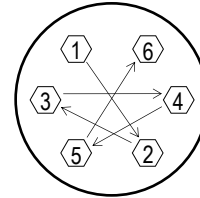

Tightening torque for center rod and out chambers.
 Center Rod 160 in-lbf {18 N-m}
 Out Chambers 105 in-lbf {12 N-m}

Tightening torque for manifold retainer bolts.
 G15SN/S 105 in-lbf {12 N-m}

General Tools:

- Socket wrench - 10mm, 17mm
- Hexagonal box wrenches - 5mm
- Open-end wrench - 10mm, 13mm, 17mm

Special Tools:

- Cap & disc remover (771132)
- Sleeve remover (713148)

Miscellaneous:

- Assembly Oil—turbine oil none additional class 1 (equivalent to ISO VG32 grade)
- Urea grease grade (NLGI) No. 2
- Thread locking agent (equivalent to LOCTITE 222)

Customer Notes

Model #: _____
 Description: _____
 Serial #: _____
 Date Installed: _____
 Department Location: _____
 Tag/Project: _____