

Please read and save this Repair Parts Manual. Read this manual and the General Operating Instructions carefully before attempting to assemble, install, operate or maintain the product described. Protect yourself and others by observing all safety information. The Safety Instructions are contained in the General Operating Instructions. Failure to comply with the safety instructions accompanying this product could result in personal injury and/or property damage! Retain instructions for future reference. AMT reserves the right to discontinue any model or change specifications at any time without incurring any obligation.  
©2017 AMT Pump Company, A Subsidiary of The Gorman-Rupp Company, All Rights Reserved.

Periodic maintenance and inspection is required on all pumps to ensure proper operation. Unit must be clear of debris and sediment. Inspect for leaks and loose bolts. Failure to do so voids warranty.

# 2MP Series Pumps

Refer to pump manual 1808-633-00 for General Operating and Safety Instructions.



## DESCRIPTION

IPT engine driven pumps are commercial duty, centrifugal, self-priming (to 20 ft. vertical lift after initially filling casing with liquid), portable units. Pumps are equipped with industry standard mechanical shaft seals. Iron suction and discharge manifolds are standard NPT threads for connection to swivel hose fitting with gasket or standard NPT pipe fittings. Pump components will handle liquids with a temperature range of 40° to 200°F (4° to 93° C). Pump only nonflammable liquids compatible with pump component materials. Standard pumps are close coupled to internal combustion engines manufactured by Honda, Briggs & Stratton, Hatz, AMT specification engines and others. All engines meet current EPA emissions requirements. Pumps (70cc and larger) are preempted from emissions regulation in California.

## SPECIFICATIONS

Standard units are constructed of cast aluminum with cast iron diffusers, suction flange and discharge manifold. Standard seals are EPDM/EPR with carbon/ silicon ceramic wear faces.

**IMPORTANT: Not for use with petroleum based liquids.**

## UNPACKING

1. Remove pump from packaging materials.
2. Package should include: pump/engine mounted in roll frame, strainer, general/safety manual, specification/parts manual and engine manual. Pump kits: Pump end, general safety manual and specification/parts manual.
3. Make sure all components are accounted for before discarding packaging material.
4. Inspect all components for damage.
5. No assembly is required for standard engine driven pumps. Pump kits must be constructed on appropriate engine.

## PREPARING UNIT FOR OPERATION

### Placing Pump

1. Always place the pump as close to the liquid source as possible. Priming efficiency and pump output will be reduced if a long (>20 ft.) suction line is used. Keep all lines as short and straight as possible. Avoid any sharp bends. Suction line cannot have loops or high spots, hose must have a gradual slope up to pump.
2. Pump/engine must be located on a solid level surface.

### Connecting Hose or Piping

**IMPORTANT:** Pipe Dope/Thread Sealant must be used on all suction and discharge connections.

1. (2) Male NPT Pipe Ports are included for use with specific hose connections.
2. All suction hose/piping connection must be air tight.

**NOTE: Pump will not prime if there are any air leaks in the suction line or connections. Use only non-collapsible hose or pipe on the suction.**

3. If collapsible hose is used on the discharge with the end of discharge line is submerged in liquid or a check valve is placed in the discharge line, a means of venting air out of the pump during the priming cycle must be employed.
4. Always use a suction strainer to keep large debris out of the pump. Position strainer well below liquid surface and on a bed of rocks or other suitable surface. If possible, tie strainer up so it is suspended off pit bottom. As a last resort, tie the strainer in a large submerged bucket if bottom of water source is too soft or muddy.

### Before Starting Engine

1. Fill engine crankcase with oil. Follow engine manufacturer recommendations for service classification and viscosity of oil as detailed in engine manual.
2. Fill fuel tank with clean, fresh fuel. Follow engine manufacturer's guidelines as listed in engine manual.
3. Always fill pump with liquid through the priming port located on top of the discharge manifold or pump casing before starting engine.

**IMPORTANT:** The pump is self-priming only when the pump is filled with liquid.

### Operation

1. Make certain pump is filled with liquid before starting engine. Failure to do so will result in damage to the mechanical shaft seal. Never run pump dry.

### **▲ WARNING**

**DO NOT USE PUMP IN EXPLOSIVE ATMOSPHERE. DO NOT PUMP VOLATILE OR FLAMMABLE LIQUIDS.**

2. Follow engine manufacturer's starting procedure. Run engine at full speed during priming. After pump has primed, speed may be reduced to regulate pump output.

# 2MP Series Pumps

- Pump will self-prime to a vertical height of 10' in less than one minute, 20' may take up to 4 minutes. If pump doesn't prime: check for air leaks, move pump closer to liquid, shorten suction line, remove loops and high spots from suction line, refill pump with liquid or see troubleshooting guide in this manual.
- Operating pump at shut-off or close to shut-off for an extended period of time, greater than a minute or two, will cause premature wear and possible internal damage. Operating at flows less than 10 gpm for models 2MP5AR, 2MP5HR, & 2MP7ZR, 20 gpm for models 2MP9AR, 2MP9HR, 2MP9ZR, & 2MP13HR, 2MP13ZR and 40 gpm for 2MP13AR should be avoided.
- Always allow engine to cool before refueling.
- Install #270 o-ring (Ref. No. D5) into bracket. Lubricate o-ring with soapy water.
- Install shaft collar (Ref. No. A15) onto engine (Ref. No. A18) shaft, large diameter end towards engine.
- Install seal plate into bracket. Fasten with four nuts (Ref. No. B3). Tighten nuts to 140 in-lb torque.
- Locate seal plate and bracket assembly onto engine (Ref. No. A18). Slide on until seal plate bosses contact engine bell housing.
- Install a #011 o-ring (Ref. No. D11) onto four socket screws (Ref. No. B2). Lubricate o-ring with soapy water. Fasten seal plate assembly to engine with screw & o-ring assemblies. Tighten screws to 140 in-lb torque.

## After Pump is Shut Down

- Always flush the pump out at the end of operation if the liquid being pumped may leave a solid or sticky residue inside of pump or if a buildup of sediment inside the pump is expected.
- Always drain pump completely of liquid if there is a chance of freezing.

## Storing Pump

- When pump is out of service for an extended period of time, completely drain liquid from casing and store pump in a dry, protected, well-ventilated area.
- Add fuel stabilizer to engine fuel tank or drain fuel from tank. Turn fuel tank valve to the off position.

## COMPLETE PUMP ASSEMBLY PROCEDURE

*Reference Repair/Replacement Part Exploded View and Lists*

**NOTE:** Do not use petroleum based lubricants with EPDM / EPR rubber seal parts and o-rings. Petroleum based products will damage EPDM/EPR components.

**NOTE:** Apply a small amount of anti-seize lubricant to bore, threaded or keyed, in impeller. If petroleum based anti-seize lubricant is used, do not allow it to contact EPDM/EPR components.

### 2MP5 (5/8-18 threaded shaft) SERIES ASSEMBLY:

#### Assemble Bracket

- Apply permanent thread locker to end of 1/4-20x1-1/2" stud (Ref. No. A4). Install studs into tapped holes in bracket (Ref. No. A1). Stud cannot extend past back face (flush).
- Lock studs in position with 1/4-20 jam nuts (Ref. No. A5).
- Apply permanent thread locker to end of 3/8-16 stud (Ref. No. A19). Install studs into tapped holes in bracket until stud bottoms.

#### Install Seal Plate / Bracket

- Install shaft seal seat (Ref. No. A17) into bore in pump side of seal plate (Ref. No. B1). Lubricate rubber cup of seat with soapy water. Press into seal plate with thumb pressure, take care not to scratch or damage seal face.

#### Install Stub Shaft

- Apply permanent thread locker onto threads of 3/8-16x3/4" hex screw (Ref. No. A14). Install screw into threaded bore in threaded end of stub shaft (Ref. No. A13).
- Lubricate inside diameter of rubber portion of shaft seal head (Ref. No. A15) with soapy water. Insert smooth end outside diameter end of stub shaft into seal head. Slide seal head onto stub shaft until seal spring washer contacts shoulder and spring compresses.
- Locate stub shaft onto end of engine shaft. Thread on clockwise until stub shaft bottoms on shaft collar. This will position the seal head. Be careful when tightening stub shaft that seal seat ring or seal head ring is not damaged.

### 2MP7 – 2MP13 (1"-14 threaded shaft) SERIES ASSEMBLY

#### Assemble Bracket

Same as 5/8-18 threaded section

#### Install Adapter

- Locate adapter (Ref. No. C3) onto engine (Ref. No. A17) bell housing. Position cast arrow up. Locate adapter machined bore on engine bell housing locating diameter.
- Install four screws (Ref. No. C4). Tighten screws to 140 in-lb torque.
- Install shaft collar (Ref. No. A15) onto engine shaft, chamfered end towards engine.

#### Install Seal Plate / Bracket

- Install shaft seal seat (Ref. No. A17) into bore in pump side of seal plate (Ref. No. C1). Lubricate rubber cup of seat with soapy water. Press into seal plate with thumb pressure, take care not to scratch or damage seal face.
- Slide seal plate over engine shaft until seal plate bottoms against adapter.
- Install #270 o-ring (Ref. No. D5) into bracket (Ref. No. A1). Lubricate o-ring with soapy water.
- Position bracket on seal plate. Seal plate outside diameter locates into large bore in bracket engine side. Slide bracket back onto seal plate and adapter. Fasten bracket to adapter with four 3/8-16 hex nuts (Ref. No. C5). Tighten nuts to 140 in-lb torque.

# 2MP Series Pumps

## Install Stub Shaft

1. Apply permanent thread locker onto threads of 3/8-16x3/4" hex screw (Ref. No. A14). Install screw into threaded bore in threaded end of stub shaft (Ref. No. A13).
2. Lubricate inside diameter of rubber portion of shaft seal head (Ref. No. A16) with soapy water. Insert smooth outside diameter of stub shaft into seal head. Slide seal head onto stub shaft. Seal head rotating ring face should be towards engine shaft end of stub shaft.
3. Locate stub shaft onto end of engine shaft. Thread on clockwise until stub shaft bottoms on end of shaft collar. This will position the seal head. Be careful when tightening stub shaft that seal seat ring or seal head ring is not damaged.

## ALL PUMPS:

### Install Second Stage Impeller & Diffuser

1. Thread impeller (Ref. No. A11) (both are identical) onto stub shaft until it bottoms on stub shaft shoulder. On 1"-14 engine shaft units, be careful that seal spring washer doesn't become pinched between impeller and stub shaft shoulder. Washer must slide up over stub shaft.
2. Install diffuser #2 (Ref. No. A2) over impeller, align holes in diffuser with 1/4-20 studs in bracket, locate on seal plate. Fasten with two 1/4-20 hex nuts (Ref. No. A3).

### ▲ WARNING

**Do not over-tighten nuts or damage to diffuser casting will result. Use thread locking compound such as Loctite and tighten nuts to 35 lb-in maximum**

3. Install #148 o-ring (Ref. No. D3) on front of diffuser #2. Lubricate o-ring with soapy water.
4. Install impeller spacer (Ref. No. A12) on stub shaft. Slide on until spacer bottoms against impeller #1.

### Install First Stage Diffuser

1. Install bushing (Ref. No. A7) into diffuser #1 (Ref. No. A6). Press bushing into bore in impeller #1 side of diffuser #1 casting.
2. Slide diffuser #1 over stub shaft. Align bushing with spacer. Diffuser #1 locates on front nose diameter of diffuser #2. Push diffuser #1 until it bottoms against diffuser #2 shoulder.
3. Rotate diffuser #1 until cast drain slot is positioned down and holes in ears align with tapped holes in diffuser #2.
4. Thread impeller #1 (Ref. No. A11) onto stub shaft until it bottoms against spacer.

### Install Diffuser Cover

1. Install #169 o-ring (Ref. No. D2) on diffuser cover (Ref. No. A8). Lubricate o-ring with soapy water.
2. Locate diffuser cover o-ring diameter into diffuser #1 bore. Position diffuser cover nose up. Align diffuser cover bolt ears with ears in diffuser #1 and diffuser #2. Slide diffuser cover into diffuser #1 until it bottoms.
3. Install three 1/4-20x3" hex screws (Ref. No. A9) with flat washer (Ref. No. A10) through the diffuser cover and

diffuser #1 threading into tapped holes in diffuser #2. Tighten screws until all parts fit metal to metal and all o-rings are compressed. Do not over tighten. Tighten screws to 60 in-lb torque.

4. Install check valve (Ref. No. D1) onto diffuser cover suction nose. Position check valve so flapper hinges at the top or 12:00 position.

### Check Rotation

1. After diffuser assembly is complete rotate driver shaft and check for interference.
2. There may be some drag or rubbing of the impeller nose in its bore. This is normal.
3. Driver shaft must rotate relatively freely. Drag of impeller nose in its bore cannot greatly restrict shaft rotation.

### Install Casing

1. Install #378 o-ring (Ref. No. D4) onto casing (Ref. No. H1). Lubricate o-ring with soapy water.
2. Install six hex screws (Ref. No. H3) through casing ears. Fix screws in position by sliding a #109 o-ring (Ref. No. H2) over each screw into casing ear back bore.
3. Install a #117 o-ring (Ref. No. D8) onto a plug (Ref. No. D7). Lubricate o-ring with soapy water. Install plug into casing drain port.
4. Position casing onto bracket, locate casing o-ring nose into bracket front bore. Slide casing into bore until it bottoms. Tighten all six hex screws in a diagonal pattern fastening casing to bracket. Tighten screws to 100 in-lb torque.
5. Check operation of check valve. Check valve must swing freely.

### Install Suction Flange

1. Position a flange gasket (Ref. No. D6) on the casing (Ref. No. H1) suction flange.
2. Position suction flange (Ref. No. H4) on flange gasket. Install four screws (Ref. No. H5) tighten to 100 in-lb torque. Alternate tightening screws in a cross pattern to reduce the chance of crushing the flange gasket.

### Assemble 3-Way Discharge Manifold

1. Install #117 o-ring (Ref. No. D8) onto a plug (Ref. No. D7). Lubricate o-ring with soapy water. Install plug into discharge manifold (Ref. No. H6) top fill port.
2. Install #316 o-ring (Ref. No. D9) in both 1" NPT caps (Ref. No. H8). Lubricate o-ring with soapy water. Thread a cap onto each 1" NPT discharge port of manifold. Tighten until o-ring compresses against end of port.
3. Install #325 o-ring (Ref. No. D10) in the 1-1/2" NPT cap (Ref. No. H9). Lubricate o-ring with soapy water. Thread cap onto 1-1/2" port of manifold. Tighten until o-ring compresses against end of port.
4. Install a section of chain (Ref. No. H11) on each cap with a screw (Ref. No. H10).
5. Free end of three chains terminate on screw installed in manifold boss located directly under 1-1/2" NPT port.

# 2MP Series Pumps

## **Install Discharge Manifold**

1. Position a flange gasket (Ref. No. D6) on the casing discharge flange.
2. Position discharge manifold assembly on flange gasket. Install four screws (Ref. No. H7) tighten to 100 in-lb torque. Alternate tightening screws in a cross pattern to reduce the chance of crushing the flange gasket.

## **REPAIR AND MAINTENANCE INSTRUCTIONS**

### **Shaft Seal Replacement**

1. Loosen six screws (Ref. No. H3) until screw disengages bracket (Ref. No. A1).
2. Remove casing assembly from bracket.
3. Remove screws (Ref. No. A9)
4. Remove diffuser cover (Ref. No. A8) and o-ring (Ref. No. D2).
5. Remove impeller #1 (Ref. No. A11). Impeller unthreads counterclockwise. Utilize the cast slots in the impeller front shroud, use a screw driver in slot and tap with a mallet to loosen impeller. Hold stub shaft (Ref. No. A13) by putting a socket wrench on screw (Ref. No. A14) installed in end of shaft if required.
6. Remove diffuser #1 (Ref. No. A6).
7. Remove spacer (Ref. No. A12) from shaft.
8. Remove o-ring (Ref. No. D3) from diffuser #2 (Ref. No. A2).
9. Remove flange nuts (Ref. No. A3).
10. Remove diffuser #2.
11. Remove impeller #2, use same technique as impeller #1 (Ref. No. A11).
12. Remove stub shaft. Utilize screw in end or machined flats, shaft unthreads counterclockwise. Removing the engine recoil starter to hold the engine shaft may be required.
13. 5/8-18 shaft engine driven pumps
  - Remove screws (Ref. No. B2) with o-rings (Ref. No. D11) and remove screws (Ref. No. E6) fastening bracket (Ref. No. A1) to frame (Ref. No. E1).
  - Remove seal plate (Ref. No. B1) & bracket assembly from engine
14. 1"-14 shaft engine driven pumps
  - Remove nuts (Ref. No. C5) holding bracket (Ref. No. A1) to adapter (Ref. No. C3) and remove screws (Ref. No. F5) fastening bracket to frame (Ref. No. F1).
  - Remove bracket and seal plate from adapter.
15. All pumps
  - Remove seal seat (stationary ring) (Ref. No. A17) from seal plate. Discard old seal.
  - Remove seal head (rotating ring, Ref. No. A16) from stub shaft. Discard old seal.
  - Replace any o-rings that are worn or damaged.
  - Rebuild pump with new replacement seal assembly, follow COMPLETE PUMP ASSEMBLY PROCEDURE.

## **Cleaning Pump**

This is a high pressure pump with closed impellers and diffusers. This pump should be used with clean liquids, it will not pass solids.

1. Remove the casing. Clean out any accumulated solids.
2. Remove all diffusers and impellers.
3. The impellers and diffuser #1 have internal cast passages that are difficult to clean. Using pressurized air or water may be required to dislodge any accumulated solids. Running a wire through the passages may also dislodge solids.
4. Reassemble pump.

### **Impeller/Diffuser Wear**

- Pump performance relies on a close running clearance of the impeller nose in its bore in the diffuser cover (impeller #1), or diffuser #2 (impeller #2).
- If the clearance, on diameter, (bore id – impeller nose od) exceeds 0.06" replacing the diffuser cover (Ref. No. A8) and/or diffuser #2 (Ref. No. A2) may be required to restore performance.
- If pump performance is acceptable there is no need to replace any parts.

### **Periodic Maintenance**

1. Clean outside of pump and engine to remove accumulated dirt, oil and grime.
2. Maintain engine according to engine manufacturer's recommendations.
3. It is recommended that a replacement shaft seal and seal kit be kept on hand at all times.
4. Check for leaks during pump operation. Leaks may occur at shaft seal, casing to bracket connection, suction and discharge manifold connections and through pump casing and bracket. Investigate and repair any leaks immediately.

**NOTE:** Engine failure due to water intrusion into crankcase caused by a leaking seal will not be covered by engine or pump warranty.

5. Mechanical shaft seals are a wear item and require periodic replacement. Seal life is dependent on many factors including: liquid pumped, sediment type, operating point and suction conditions.
6. Inspect for loose fasteners. Tighten any loose fasteners immediately.

# 2MP Series Pumps

Problem	Possible Cause(s)	Corrective Action
Pump fails to prime	1 Pump not filled with liquid	1 Add liquid to pump through priming port
	2 Air leak at suction line connection	2 Add sealant to connection
	3 Worn suction connection gasket	3 Replace suction gasket
	4 Leaking suction line	4 Inspect, repair or replace suction line
	5 Engine speed too low	5 Run engine at maximum speed
	6 Worn or broken volute or impeller	6 Replace parts as required
	7 Leaking/worn mechanical shaft seal	7 Replace mechanical shaft seal
	8 Clogged suction strainer/line	8 Clean strainer and suction line
	9 Suction lift too great (25 ft. max)	9 Reduce lift
	10 Suction line too long	10 Reduce length to under 30 feet
	11 Pump is air locked	11 Vent pump discharge through priming port
Priming remedies that will NOT work:		
<ol style="list-style-type: none"> <li>Holding suction line out of liquid source and forcing liquid into end while pump is running</li> <li>Pinching off the discharge line to "build up pressure".</li> <li>Holding hand against end of suction line or pump suction port to "feel" for suction.</li> </ol>		
Follow above priming troubleshooting guide.		
If pump still will not prime after all corrective action is exhausted, check pump priming capacity by:		
<ol style="list-style-type: none"> <li>Install a vacuum gauge on capped suction port. Gauge to suction port connection must be 100% air tight.</li> <li>Fill pump casing completely with water.</li> <li>Run pump at full speed, some water will be thrown out of discharge.</li> <li>Vacuum gauge should register 18-22 inches of mercury within a minute or so. <ol style="list-style-type: none"> <li>If vacuum registers below 18 in of hg check gauge to pump connection for air leaks, inspect/replace volute, impeller and shaft seal as required.</li> <li>If vacuum gauge value is within range pump is working correctly. The problem is not the pump.</li> </ol> </li> </ol>		
Reduced capacity or discharge pressure	1. Clogged strainer or lines	1. Clean strainer, suction and discharge lines
	2. High friction loss in line	2. Remove kinks and elbows, reduce length
	3. Discharge head too high	3. Lower end of discharge line, remove nozzles
	4. Engine speed too low	4. Increase engine speed
	5. Drop in engine output	5. Repair engine
	6. Clogged impeller	6. Remove clog
	7. Worn/damaged impeller or volute	7. Replace parts as required
Pump will not work/engine will not turn over	1. Clogged pump	1. Remove clog between impeller and volute
	2. Pump parts rusted together	2. Disassemble pump, free parts
	3. Damaged impeller or volute	3. Replace volute or impeller
	4. Engine seized	4. Remove pump from engine, check engine itself
Pump will not work/engine runs	1. Impeller stripped/key sheared	1. Disassemble pump, replace parts/engine
	2. Pump impeller/volute clogged	2. Clean pump
	3. Will not prime	3. See Priming Troubleshooting Section
	4. Insufficient liquid supply	4. Increase liquid supply

# 2MP Series Pumps

**For Repair Parts contact dealer where pump was purchased.**

Please provide following information:

-Model Number

-Serial Number (if any)

Part description and number as shown in parts list

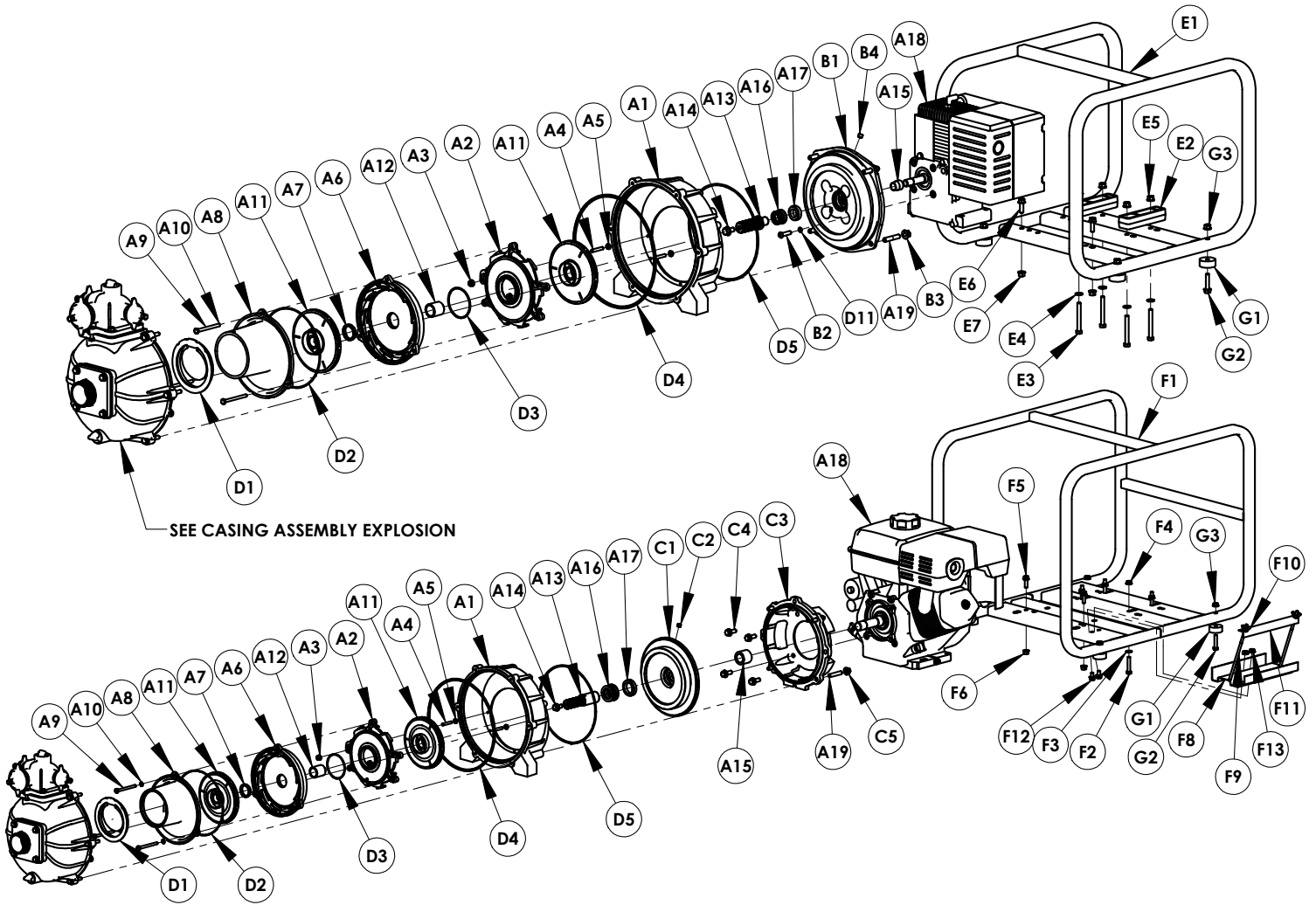

Figure 1 - Repair Parts Illustrations

# 2MP Series Pumps

***For Repair Parts contact dealer where pump was purchased.***

*Please provide following information:*

*-Model Number*

*-Serial Number (if any)*

*Part description and number as shown in parts list*

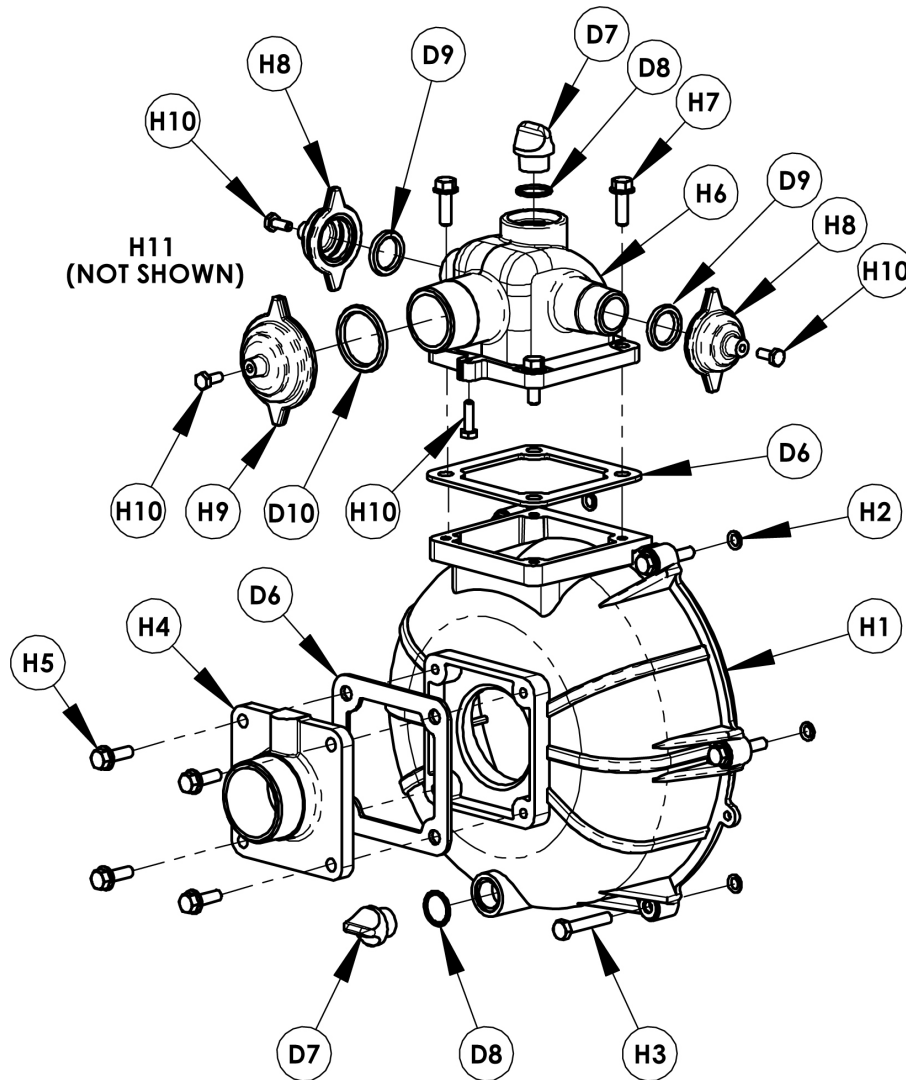

Figure 2 - Repair Parts Illustrations - Casing

## Repair Parts List

Ref.		Vanguard 6.5	Honda GX160	Hatz 1B30	Vanguard 10	Honda GX270	Hatz 1B40	Vanguard 13	Honda GX390	Hatz 1B50	
No.	Description	2MP5AR	2MP5HR	2MP7ZR	2MP9AR	2MP9HR	2MP9ZR	2MP13AR	2MP13HR	2MP13ZR	Qty.
A1	Bracket Kit (includes Ref. Nos. A1, A4, A5, and A19)	2MP5-030-96	2MP5-030-96	2MPX-030-96	2MPX-030-96	2MPX-030-96	2MPX-030-96	2MPX-030-96	2MPX-030-96	2MPX-030-96	1
A2	Diffuser #2 Kit (includes Ref. Nos. A2 and A3)	2MPX-152-95	2MPX-152-95	2MPX-152-95	2MPX-158-95	2MPX-158-95	2MPX-158-95	2MPX-157-95	2MPX-157-95	2MPX-157-95	1
A3	1/4-20 Hex Flange Nut	Incl. w/Ref. A2	Incl. w/Ref. A2	Incl. w/Ref. A2	Incl. w/Ref. A2	Incl. w/Ref. A2	Incl. w/Ref. A2	Incl. w/Ref. A2	Incl. w/Ref. A2	Incl. w/Ref. A2	2
A4	1/4-20x1-1/2" Stud	Incl. w/Ref. A1	Incl. w/Ref. A1	Incl. w/Ref. A1	Incl. w/Ref. A1	Incl. w/Ref. A1	Incl. w/Ref. A1	Incl. w/Ref. A1	Incl. w/Ref. A1	Incl. w/Ref. A1	2
A5	1/4-20 Hex Jam Nut	Incl. w/Ref. A1	Incl. w/Ref. A1	Incl. w/Ref. A1	Incl. w/Ref. A1	Incl. w/Ref. A1	Incl. w/Ref. A1	Incl. w/Ref. A1	Incl. w/Ref. A1	Incl. w/Ref. A1	2
A6	Diffuser #1 Kit (includes Ref. Nos. A6 and A7)	2MPX-151-95	2MPX-151-95	2MPX-151-95	2MPX-153-95	2MPX-153-95	2MPX-153-95	2MPX-156-95	2MPX-156-95	2MPX-156-95	1
A7	Bushing	Incl. w/Ref. A6	Incl. w/Ref. A6	Incl. w/Ref. A6	Incl. w/Ref. A6	Incl. w/Ref. A6	Incl. w/Ref. A6	Incl. w/Ref. A6	Incl. w/Ref. A6	Incl. w/Ref. A6	1
A8	Diffuser Cover Kit (includes Ref. Nos. A8, A9, and A10)	2MPX-150-95	2MPX-150-95	2MP7-150-95	2MPX-154-95	2MPX-154-95	2MPX-154-95	2MPX-155-95	2MPX-155-95	2MPX-155-95	1
A9	1/4-20x3" Hex Screw	Incl. w/Ref. A8	Incl. w/Ref. A8	Incl. w/Ref. A8	Incl. w/Ref. A8	Incl. w/Ref. A8	Incl. w/Ref. A8	Incl. w/Ref. A8	Incl. w/Ref. A8	Incl. w/Ref. A8	3
A10	1/4 Flat Washer	Incl. w/Ref. A8	Incl. w/Ref. A8	Incl. w/Ref. A8	Incl. w/Ref. A8	Incl. w/Ref. A8	Incl. w/Ref. A8	Incl. w/Ref. A8	Incl. w/Ref. A8	Incl. w/Ref. A8	3
A11	Impeller Kit (includes Ref. Nos. A11 and A12)	2MP5-011-96	2MP5-010-96	2MP5-011-96	2MP9-010-96	2MP9-010-96	2MP9-010-96	2MPX-010-96	2MPX-010-96	2MPX-010-96	1
A12	Spacer	Incl. w/Ref. A11	Incl. w/Ref. A11	Incl. w/Ref. A11	Incl. w/Ref. A11	Incl. w/Ref. A11	Incl. w/Ref. A11	Incl. w/Ref. A11	Incl. w/Ref. A11	Incl. w/Ref. A11	1
A13	Stub Shaft Kit (includes Ref. Nos. A13, A14 and A15)	2MPX-140-90	2MPX-140-90	2MP9-140-90	2MP9-140-90	2MP9-140-90	2MP9-140-90	2M13-140-90	2MP9-140-90	2MP9-140-90	1
A14	3/8-16x3/4" Hex Screw	Incl. w/Ref. A13	Incl. w/Ref. A13	Incl. w/Ref. A13	Incl. w/Ref. A13	Incl. w/Ref. A13	Incl. w/Ref. A13	Incl. w/Ref. A13	Incl. w/Ref. A13	Incl. w/Ref. A13	1
A15	Shaft Collar	Incl. w/Ref. A13	Incl. w/Ref. A13	Incl. w/Ref. A13	Incl. w/Ref. A13	Incl. w/Ref. A13	Incl. w/Ref. A13	Incl. w/Ref. A13	Incl. w/Ref. A13	Incl. w/Ref. A13	1
A16,A17	Shaft Seal Kit	1643-324-00	1643-324-00	1646-324-00	1646-324-00	1646-324-00	1646-324-00	1646-324-00	1646-324-00	1646-324-00	1
A18	Engine	1639-049-00	1639-036-00	1630-030-00	1639-060-00	1639-026-00	1630-040-00	1639-063-00	1639-031-00	1639-050-00	1
A19	3/8-16x1-1/2" Stud	Incl. w/Ref. A1	Incl. w/Ref. A1	N/A	N/A	N/A	N/A	N/A	N/A	N/A	4
A19	3/8-16x2" Stud	N/A	N/A	Incl. w/Ref. A1	Incl. w/Ref. A1	Incl. w/Ref. A1	Incl. w/Ref. A1	Incl. w/Ref. A1	Incl. w/Ref. A1	Incl. w/Ref. A1	4
B1	Seal Plate Kit (includes Ref. Nos. B1, B2, B3 and B4)	2MPX-020-96	2MPX-020-96	N/A	N/A	N/A	N/A	N/A	N/A	N/A	1
B2	5/16-24x1-1/4" Soc Screw	Incl. w/Ref. B1	Incl. w/Ref. B1	N/A	N/A	N/A	N/A	N/A	N/A	N/A	4
B3	3/8-16 Hex Nut	Incl. w/Ref. B1	Incl. w/Ref. B1	N/A	N/A	N/A	N/A	N/A	N/A	N/A	4
B4	1/8" NPT Plug	Incl. w/Ref. B1	Incl. w/Ref. B1	N/A	N/A	N/A	N/A	N/A	N/A	N/A	1
C1	Seal Plate Kit (includes Ref. Nos. C1, and C2)	N/A	N/A	2MPX-021-96	2MPX-022-96	2MPX-022-96	2MPX-022-96	2MPX-022-96	2MPX-022-96	2MPX-022-96	1
C2	1/8" NPT Plug	N/A	N/A	Incl. w/Ref. C1	Incl. w/Ref. C1	Incl. w/Ref. C1	Incl. w/Ref. C1	Incl. w/Ref. C1	Incl. w/Ref. C1	Incl. w/Ref. C1	1
C3	Adapter Kit (includes Ref. Nos. C3, C4, and C5)	N/A	N/A	2MPX-032-96	2MPX-031-96	2MPX-031-96	2MPX-032-96	2MPX-031-96	2MPX-032-96	3S9X-031-96	1
C4	3/8-16x1" Hex Screw	N/A	N/A	N/A	Incl. w/Ref. C3	Incl. w/Ref. C3	N/A	Incl. w/Ref. C3	Incl. w/Ref. C3	N/A	4
C4	M8x35mm Hex Screw	N/A	N/A	Incl. w/Ref. C3	N/A	N/A	Incl. w/Ref. C3	N/A	N/A	N/A	4
C4	M10x30mm Hex Screw	N/A	N/A	N/A	N/A	N/A	N/A	N/A	N/A	Incl. w/Ref. C3	4
C5	3/4-16 Hex Nut	N/A	N/A	Incl. w/Ref. C3	Incl. w/Ref. C3	Incl. w/Ref. C3	Incl. w/Ref. C3	Incl. w/Ref. C3	Incl. w/Ref. C3	N/A	4
C5	M10 Lock Washer	N/A	N/A	N/A	N/A	N/A	N/A	N/A	N/A	Incl. w/Ref. C3	4

Repair Parts List Continued on Next Page

2MPX-250-00

G

3/2017

Ref.		Vanguard 6.5	Honda GX160	Hatz 1B30	Vanguard 10	Honda GX270	Hatz 1B40	Vanguard 13	Honda GX390	Hatz 1B50	
No.	Description	2MP5AR	2MP5HR	2MP7ZR	2MP9AR	2MP9HR	2MP9ZR	2MP13AR	2MP13HR	2MP13ZR	Qty.
KIT	Gasket / O-Ring (EPDM) Kit (includes Ref. Nos. D1 to D11)	2MPE-300-90	2MPE-300-90	2MPE-300-91	2MPE-300-91	2MPE-300-91	2MPE-300-91	2MPE-300-91	2MPE-300-91	2MPE-300-91	1
D1	Check Valve	Incl. w/Ref. KIT	Incl. w/Ref. KIT	Incl. w/Ref. KIT	Incl. w/Ref. KIT	Incl. w/Ref. KIT	Incl. w/Ref. KIT	Incl. w/Ref. KIT	Incl. w/Ref. KIT	Incl. w/Ref. KIT	1
D2	#169 O-Ring	Incl. w/Ref. KIT	Incl. w/Ref. KIT	Incl. w/Ref. KIT	Incl. w/Ref. KIT	Incl. w/Ref. KIT	Incl. w/Ref. KIT	Incl. w/Ref. KIT	Incl. w/Ref. KIT	Incl. w/Ref. KIT	1
D3	#148 O-Ring	Incl. w/Ref. KIT	Incl. w/Ref. KIT	Incl. w/Ref. KIT	Incl. w/Ref. KIT	Incl. w/Ref. KIT	Incl. w/Ref. KIT	Incl. w/Ref. KIT	Incl. w/Ref. KIT	Incl. w/Ref. KIT	1
D4	#378 O-Ring	Incl. w/Ref. KIT	Incl. w/Ref. KIT	Incl. w/Ref. KIT	Incl. w/Ref. KIT	Incl. w/Ref. KIT	Incl. w/Ref. KIT	Incl. w/Ref. KIT	Incl. w/Ref. KIT	Incl. w/Ref. KIT	1
D5	#270 O-Ring	Incl. w/Ref. KIT	Incl. w/Ref. KIT	Incl. w/Ref. KIT	Incl. w/Ref. KIT	Incl. w/Ref. KIT	Incl. w/Ref. KIT	Incl. w/Ref. KIT	Incl. w/Ref. KIT	Incl. w/Ref. KIT	1
D6	Flange Gasket	Incl. w/Ref. KIT	Incl. w/Ref. KIT	Incl. w/Ref. KIT	Incl. w/Ref. KIT	Incl. w/Ref. KIT	Incl. w/Ref. KIT	Incl. w/Ref. KIT	Incl. w/Ref. KIT	Incl. w/Ref. KIT	2
D7	Plug	Incl. w/Ref. KIT	Incl. w/Ref. KIT	Incl. w/Ref. KIT	Incl. w/Ref. KIT	Incl. w/Ref. KIT	Incl. w/Ref. KIT	Incl. w/Ref. KIT	Incl. w/Ref. KIT	Incl. w/Ref. KIT	2
D8	#117 O-Ring (plug)	Incl. w/Ref. KIT	Incl. w/Ref. KIT	Incl. w/Ref. KIT	Incl. w/Ref. KIT	Incl. w/Ref. KIT	Incl. w/Ref. KIT	Incl. w/Ref. KIT	Incl. w/Ref. KIT	Incl. w/Ref. KIT	2
D9	#316 O-Ring	Incl. w/Ref. KIT	Incl. w/Ref. KIT	Incl. w/Ref. KIT	Incl. w/Ref. KIT	Incl. w/Ref. KIT	Incl. w/Ref. KIT	Incl. w/Ref. KIT	Incl. w/Ref. KIT	Incl. w/Ref. KIT	2
D10	#325 O-Ring	Incl. w/Ref. KIT	Incl. w/Ref. KIT	Incl. w/Ref. KIT	Incl. w/Ref. KIT	Incl. w/Ref. KIT	Incl. w/Ref. KIT	Incl. w/Ref. KIT	Incl. w/Ref. KIT	Incl. w/Ref. KIT	1
D11	#011 O-Ring	Incl. w/Ref. KIT	Incl. w/Ref. KIT	N/A	N/A	N/A	N/A	N/A	N/A	N/A	4
E1	Frame	C400-100-00	C400-100-00	N/A	N/A	N/A	N/A	N/A	N/A	N/A	1
E2	Raising Block	Incl. w/Ref. E8	Incl. w/Ref. E8	N/A	N/A	N/A	N/A	N/A	N/A	N/A	2
E3	5/16-18x2-3/4" Hex Bolt	Incl. w/Ref. E8	Incl. w/Ref. E8	N/A	N/A	N/A	N/A	N/A	N/A	N/A	4
E4	5/16 Flat Washer	Incl. w/Ref. E8	Incl. w/Ref. E8	N/A	N/A	N/A	N/A	N/A	N/A	N/A	4
E5	5/16-18 Hex Flange Nut	Incl. w/Ref. E8	Incl. w/Ref. E8	N/A	N/A	N/A	N/A	N/A	N/A	N/A	4
E6	5/16-18x1" Hex Bolt	Incl. w/Ref. E8	Incl. w/Ref. E8	N/A	N/A	N/A	N/A	N/A	N/A	N/A	2
E7	5/16-18 Hex Flange Nut	Incl. w/Ref. E8	Incl. w/Ref. E8	N/A	N/A	N/A	N/A	N/A	N/A	N/A	2
E8	Mounting Hardware Kit (includes Ref. Nos. E2, E3, E4, E5, E6, and E7)	2MP5-100-90	2MP5-100-90	N/A	N/A	N/A	N/A	N/A	N/A	N/A	1
F1	Frame	N/A	N/A	C401-100-00	C401-100-00	C401-100-00	C401-100-00	C401-100-00	C401-100-00	C401-100-00	1
F2	5/16-18x1-1/2" Hex Bolt	N/A	N/A	Incl. w/Ref. F14	N/A	N/A	N/A	N/A	N/A	N/A	4
F2	5/16-18x1-3/4" Hex Bolt	N/A	N/A	N/A	Incl. w/Ref. F14	Incl. w/Ref. F14	Incl. w/Ref. F14	Incl. w/Ref. F14	Incl. w/Ref. F14	Incl. w/Ref. F14	4
F3	5/16 Flat Washer	N/A	N/A	Incl. w/Ref. F14	Incl. w/Ref. F14	Incl. w/Ref. F14	Incl. w/Ref. F14	Incl. w/Ref. F14	Incl. w/Ref. F14	Incl. w/Ref. F14	4
F4	5/16-18 Hex Flange Nut	N/A	N/A	Incl. w/Ref. F14	Incl. w/Ref. F14	Incl. w/Ref. F14	Incl. w/Ref. F14	Incl. w/Ref. F14	Incl. w/Ref. F14	Incl. w/Ref. F14	4
F5	5/16-18x1-1/2" Hex Bolt	N/A	N/A	Incl. w/Ref. F14	N/A	N/A	N/A	N/A	N/A	N/A	2
F5	5/16-18x1" Hex Bolt	N/A	N/A	N/A	Incl. w/Ref. F14	Incl. w/Ref. F14	N/A	Incl. w/Ref. F14	Incl. w/Ref. F14	Incl. w/Ref. F14	2
F5	5/16-18x1-3/4" Hex Bolt	N/A	N/A	N/A	N/A	N/A	Incl. w/Ref. F14	N/A	N/A	N/A	2
F6	5/16-18 Hex Flange Nut	N/A	N/A	Incl. w/Ref. F14	Incl. w/Ref. F14	Incl. w/Ref. F14	Incl. w/Ref. F14	Incl. w/Ref. F14	Incl. w/Ref. F14	Incl. w/Ref. F14	2
F7	Bracket Raising Block 0.5"	N/A	N/A	Incl. w/Ref. F14	N/A	N/A	N/A	N/A	N/A	N/A	2
F7	Bracket Raising Block 0.88"	N/A	N/A	N/A	N/A	N/A	Incl. w/Ref. F14	N/A	N/A	N/A	2
F8	Battery Base Plate	N/A	N/A	Incl. w/Ref. F15	N/A	N/A	Incl. w/Ref. F15	Incl. w/Ref. F15	Incl. w/Ref. F15	Incl. w/Ref. F15	1
F9	1/4-20 Hook Bolt	N/A	N/A	Incl. w/Ref. F15	N/A	N/A	Incl. w/Ref. F15	Incl. w/Ref. F15	Incl. w/Ref. F15	Incl. w/Ref. F15	2
F10	1/4-20 Wing Nut	N/A	N/A	Incl. w/Ref. F15	N/A	N/A	Incl. w/Ref. F15	Incl. w/Ref. F15	Incl. w/Ref. F15	Incl. w/Ref. F15	2
F11	Battery Hold Down	N/A	N/A	Incl. w/Ref. F15	N/A	N/A	Incl. w/Ref. F15	Incl. w/Ref. F15	Incl. w/Ref. F15	Incl. w/Ref. F15	1
F12	5/16-18x1/2" Hex Bolt	N/A	N/A	Incl. w/Ref. F15	N/A	N/A	Incl. w/Ref. F15	Incl. w/Ref. F15	Incl. w/Ref. F15	Incl. w/Ref. F15	2
F13	5/16-18 Hex Flange Nut	N/A	N/A	Incl. w/Ref. F15	N/A	N/A	Incl. w/Ref. F15	Incl. w/Ref. F15	Incl. w/Ref. F15	Incl. w/Ref. F15	2
F14	Mounting Hardware Kit (includes Ref. Nos. F2, F3, F4, F5, F6, and F7)	N/A	N/A	2MP7-100-90	2MP9-100-90	2MP9-100-90	2MP9-102-90	2MP9-100-90	2MP9-100-90	2MP9-100-90	1
F15	Battery Hardware Kit (includes Ref. Nos. F8, F9, F10, F11, F12, and F13)	N/A	N/A	C401-101-90	N/A	N/A	C401-101-90	C401-101-90	C401-101-90	C401-101-90	1

Repair Parts List Continued on Next Page

2MPX-250-00

Ref.		Vanguard 6.5	Honda GX160	Hatz 1B30	Vanguard 10	Honda GX270	Hatz 1B40	Vanguard 13	Honda GX390	Hatz 1B50	
No.	Description	2MP5AR	2MP5HR	2MP7ZR	2MP9AR	2MP9HR	2MP9ZR	2MP13AR	2MP13HR	2MP13ZR	Qty.
G1	Rubber Foot Kit (includes Ref. Nos. G1, G2, and G3)	C400-100-91	C400-100-91	C400-100-91	C400-100-91	C400-100-91	C400-100-91	C400-100-91	C400-100-91	C400-100-91	1
G2	5/16-18x1-1/2" Hex Bolt	Incl. w/Ref. G1	Incl. w/Ref. G1	Incl. w/Ref. G1	Incl. w/Ref. G1	Incl. w/Ref. G1	Incl. w/Ref. G1	Incl. w/Ref. G1	Incl. w/Ref. G1	Incl. w/Ref. G1	4
G3	5/16-18 Hex Flange Nut	Incl. w/Ref. G1	Incl. w/Ref. G1	Incl. w/Ref. G1	Incl. w/Ref. G1	Incl. w/Ref. G1	Incl. w/Ref. G1	Incl. w/Ref. G1	Incl. w/Ref. G1	Incl. w/Ref. G1	4
H1	Casing Kit (includes Ref. Nos. H1, H2 and H3)	2MPX-001-96	2MPX-001-96	2MPX-001-96	2MPX-001-96	2MPX-001-96	2MPX-001-96	2MPX-001-96	2MPX-001-96	2MPX-001-96	1
H2	Screw Keeper #109 O-Ring	Incl. w/Ref. H1	Incl. w/Ref. H1	Incl. w/Ref. H1	Incl. w/Ref. H1	Incl. w/Ref. H1	Incl. w/Ref. H1	Incl. w/Ref. H1	Incl. w/Ref. H1	Incl. w/Ref. H1	6
H3	5/16-18x1-1/4" Hex Screw	Incl. w/Ref. H1	Incl. w/Ref. H1	Incl. w/Ref. H1	Incl. w/Ref. H1	Incl. w/Ref. H1	Incl. w/Ref. H1	Incl. w/Ref. H1	Incl. w/Ref. H1	Incl. w/Ref. H1	6
H4	Suction Flange Kit (includes Ref. Nos. H4 and H5)	2MPX-050-95	2MPX-050-95	2MPX-050-95	2MPX-050-95	2MPX-050-95	2MPX-050-95	2MPX-050-95	2MPX-050-95	2MPX-050-95	1
H5	5/16-18x1" Hex Screw	Incl. w/Ref. H4	Incl. w/Ref. H4	Incl. w/Ref. H4	Incl. w/Ref. H4	Incl. w/Ref. H4	Incl. w/Ref. H4	Incl. w/Ref. H4	Incl. w/Ref. H4	Incl. w/Ref. H4	4
H6	Discharge Manifold Kit (includes Ref. Nos. H6, H7, H8, H9, H10, and H11)	2MPX-080-95	2MPX-080-95	2MPX-080-95	2MPX-080-95	2MPX-080-95	2MPX-080-95	2MPX-080-95	2MPX-080-95	2MPX-080-95	1
H7	5/16-18x1" Hex Screw	Incl. w/Ref. H6	Incl. w/Ref. H6	Incl. w/Ref. H6	Incl. w/Ref. H6	Incl. w/Ref. H6	Incl. w/Ref. H6	Incl. w/Ref. H6	Incl. w/Ref. H6	Incl. w/Ref. H6	4
H8	1" NPT Cap	Incl. w/Ref. H6	Incl. w/Ref. H6	Incl. w/Ref. H6	Incl. w/Ref. H6	Incl. w/Ref. H6	Incl. w/Ref. H6	Incl. w/Ref. H6	Incl. w/Ref. H6	Incl. w/Ref. H6	2
H9	1-1/2" NPT Cap	Incl. w/Ref. H6	Incl. w/Ref. H6	Incl. w/Ref. H6	Incl. w/Ref. H6	Incl. w/Ref. H6	Incl. w/Ref. H6	Incl. w/Ref. H6	Incl. w/Ref. H6	Incl. w/Ref. H6	1
H10	1/4-20x3/4" Hex Screw	Incl. w/Ref. H6	Incl. w/Ref. H6	Incl. w/Ref. H6	Incl. w/Ref. H6	Incl. w/Ref. H6	Incl. w/Ref. H6	Incl. w/Ref. H6	Incl. w/Ref. H6	Incl. w/Ref. H6	4
H11	Cap Chain (not shown)	Incl. w/Ref. H6	Incl. w/Ref. H6	Incl. w/Ref. H6	Incl. w/Ref. H6	Incl. w/Ref. H6	Incl. w/Ref. H6	Incl. w/Ref. H6	Incl. w/Ref. H6	Incl. w/Ref. H6	3
N/S	Suction Strainer 2"NPTx1/8" (not shown & not included with pedestal models)	44-315	44-315	44-315	44-315	44-315	44-315	44-315	44-315	44-315	1
N/S	12" Negative Battery Cable Assembly (Black) not shown	N/A	N/A	3102-104-90	N/A	N/A	3102-104-90	3102-104-90	3102-104-90	3102-104-90	1
N/S	30" Positive Battery Cable Assembly (Red) not shown	N/A	N/A	3102-105-90	N/A	N/A	3102-105-90	3102-105-90	3102-105-90	3102-105-90	1
N/S	Pedestal Shaft Drive Kit (not shown)	2870-090-99	2870-090-99	2870-090-99	2870-090-99	2870-090-99	2870-090-99	2870-090-99	2870-090-99	2870-090-99	1
N/S	Adapter Pedestal Kit (not shown)	3P9X-035-96	3P9X-035-96	3P9X-035-96	3P9X-035-96	3P9X-035-96	3P9X-035-96	3P9X-035-96	3P9X-035-96	3P9X-035-96	1

10

3/2017



AMT Pump Company  
(herein "AMT")  
400 Spring Street  
Royersford, PA 19468  
Phone: (610) 948-3800  
Fax: (610) 948-5300  
www.amtpump.com



## General Information

**SALES POLICY:** AMT products are sold through our established Distributors. We do not sell direct to the consumer or organization not entitled to trade recognition. Therefore, possession of our catalogs and/or price list(s) does not infer an offer to sell.

**MINIMUM ORDER:** We appreciate your order, however, all orders are subject to a minimum \$35.00 net invoice charge (excluding freight). This applies to all pump and parts purchase orders.

**PRICES:** Prices are subject to change without notice. All orders accepted are subject to prices in effect at time of shipment.

**PAYMENT TERMS:** Terms, upon establishment of credit, are Net 30 days. Past due accounts may be subject to a service charge of 1.5% per month. Domestic or assignable letter of credit is required for all export trade.

**PAST DUE ACCOUNTS:** AMT reserves the right to withhold open account shipments on any past due account. Invoices are considered past due after thirty (30) days. In the interest of sound business, all orders are subject to approval of the Credit Department.

**SHIPPING INSTRUCTIONS:** All shipments will be made F.O.B. the factory. Where instructions for shipment do not appear on the order, the shipment will be made according to our best judgment. Full risk of loss (including transportation delays and losses) shall pass to the customer upon delivery of the products to the carrier at the F.O.B. point. When loss or delay occurs, primary responsibility for tracing rests with the customer. When there is LOSS or APPARENT VISIBLE DAMAGE to a shipment, when tendered for delivery, **DO NOT** give the carrier a clear receipt. Note such damage on the carrier's delivery receipt and **HAVE THE DRIVER SIGN THE RECEIPT.**

**PRODUCT REVISIONS:** AMT reserves the right to discontinue, change or improve its products or any portions thereof without being obligated to provide such a change or improvement for units sold and/or shipped prior to such a change or improvement.

## 12 Month Limited Warranty

### EXTENT AND DURATION OF LIMITED WARRANTY

**Coverage:** AMT Pump Company (herein "AMT") or IPT Pumps by Gorman-Rupp (herein "IPT") or Gorman-Rupp Industries Division of The Gorman-Rupp Company, Patterson, or the Gorman-Rupp Company (herein referred to as "G-R Unit") each individually warrants that its products and parts shall be free from defects in material and workmanship for twelve (12) months from the date of purchase by the original end user when installation is made and maintenance is performed in accordance with G-R Unit's recommendations. Wear and tear resulting from use and items normally consumed in use are not covered.

### EXCEPTIONS

( A ) This Limited Warranty shall not apply to mechanical seals in AMT or IPT pumps and the following products and parts: engines, motors, trade accessories and all other products, components, parts and materials not manufactured by the G-R Units. These items may, however, be covered by the warranties of their respective manufacturers. ( B ) This warranty does not extend to or apply to any unit which has been repaired or altered at any place other than by a G-R Unit, or by persons not expressly approved by a G-R Unit to make repairs or alterations, nor to any unit the serial number, model number or identification of which has been removed, defaced or altered. ( C ) This warranty does not extend to any product manufactured by a G-R Unit, which has been subjected to mis-use, neglect, accident, improper installation, or use in violation of instructions furnished by a G-R Unit. ( D ) Pump Kits: This warranty does not extend to any product sold by a G-R Unit unassembled as a Pump Kit. Pump Kits are warranted against defects in material and workmanship for 60 days from the date of shipment from a G-R Unit. Any Pump Kit parts deemed defective by a G-R Unit will be replaced free of charge within 60 days of shipment. Pump Kits are not returnable for credit.

### LIMITATIONS

**THE G-R UNITS' SOLE AND EXCLUSIVE WARRANTY WITH RESPECT TO THEIR PRODUCTS AND PARTS IS THIS LIMITED WARRANTY. THIS LIMITED WARRANTY IS IN LIEU OF ALL OTHER EXPRESS AND/OR IMPLIED WARRANTIES, INCLUDING IMPLIED WARRANTIES OF MERCHANTABILITY AND FITNESS FOR PARTICULAR PURPOSE.**

### EXCLUSIVE REMEDY AND DAMAGES

The sole and exclusive remedy for breach of this Warranty by a G-R Unit and the entire extent of its liability for such breach or for damages arising from the use of the products and parts covered under this Limited Warranty, shall be as follows:

**LEAD TIME:** Products designated "Quick Ship Product", also referred to as "QSP" will normally be shipped within 24 hours of receipt of a non-cancellable purchase order. Only limited quantities of "QSP" pumps are available.

**STANDARD LEAD TIME:** Lead time is two weeks for all non "QSP" product. AMT reserves the right to revise lead times as required due to availability of materials and all other causes beyond our control.

**VIP SHIPMENT:** Select AMT and IPT branded pumps are available for next day shipment for non-QSP (Quick Ship Products) items and subjected to a specific model surcharge per unit noted in the respective price book. Requires calling for availability, confirmation and a non-cancellable purchase order or credit card payment prior to shipment. The expedited shipping charges are an additional cost added separately from the VIP charges per item. AMT reserves the right to revise lead times as required due to availability of materials and all other causes beyond our control. QSP quantities are limited as determined by AMT.

ALL purchase orders must be submitted via hard copy sent to AMT customer service department by fax, EDI or e-mail.

**RETURN GOODS POLICY:** Goods shall not be returned without a return goods authorization number (RGA) issued by AMT customer service. The RGA number must be listed on the packing list. Only current model and part numbers with a valid date code may be returned (within one year from date of purchase). **A 20% restocking and packaging charge will apply to all returns. All shipping charges must be pre-paid. No exceptions.**

**ORDER CHANGES BY CUSTOMER:** Orders in process may not be changed except with written consent and may be subject to special charges.

- 1. Repair or Replacement:** If inspection shows that any G-R Unit product or part covered under this Limited Warranty is defective in materials or workmanship, the G-R Unit shall repair or replace the defective or non-conforming product or part without charge, whichever the G-R Unit chooses. You must have properly maintained and used the product or part claimed to be defective in accordance with the maintenance schedule or manual, which comes with the product. No allowance will be made for labor, installation, removal, transportation or other charges incurred by you in connection with such repair or replacement.
- 2. To obtain the above remedy:**
  - A.** Immediately notify the G-R Unit upon discovery of the claimed defect in materials or workmanship and provide the serial number or date code of the product and/or part(s) or provide the G-R Unit with the invoice or bill of sale referencing the product by no later than the expiration date of the warranty period.
  - B.** The G-R Unit will advise whether inspection will be necessary and how whether repair or replacement will be made. If inspection by the G-R Unit is necessary, the pump or defective part must be sent freight pre-paid to the G-R Unit. Return shipment will be F.O.B. the G-R Unit's plant.
  - C. Return Goods Authorization Requirement:** No product will be accepted for return or replacement without the prior written authorization of the G-R Unit. Upon such authorization, and in accordance with instructions from the G-R Unit, the product will be returned to the G-R Unit, shipping charges prepaid by the Buyer.
- 3. Damages:** The G-R Unit's liability for damages for breach of this Limited Warranty shall not exceed the amount of the purchase price of the product or part(s) in respect to which Such damages are claimed. **IN NO EVENT SHALL THE G-R UNITS BE LIABLE FOR INCIDENTAL, CONSEQUENTIAL OR SPECIAL DAMAGES FOR BREACH OF THIS LIMITED WARRANTY.**

Some states do not allow the exclusion or limitation of incidental or consequential damages, so the above limitation or exclusion may not apply to you. This Limited Warranty gives you specific legal rights, and you may also have other rights, which vary from state to state.



**A Gorman-Rupp Company**

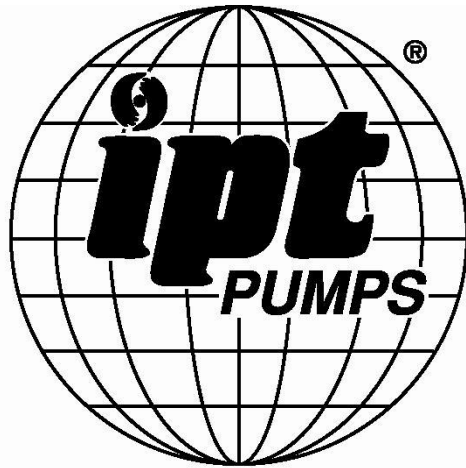

BY  
**GORMAN-RUPP®**

[www.amtpump.com](http://www.amtpump.com)