

Please read and save this Repair Parts Manual. Read this manual and the General Operating Instructions carefully before attempting to assemble, install, operate or maintain the product described. Protect yourself and others by observing all safety information. The Safety Instructions are contained in the General Operating Instructions. Failure to comply with the safety instructions accompanying this product could result in personal injury and/or property damage! Retain instructions for future reference. AMT reserves the right to discontinue any model or change specifications at any time without incurring any obligation.

©2012 American Machine & Tool Co., Inc. of PA, A Subsidiary of The Gorman-Rupp Company, All Rights Reserved.

Periodic maintenance and inspection is required on all pumps to insure proper operation. Unit must be clear of debris and sediment. Inspect for leaks and loose bolts. Failure to do so voids warranty.

# Polypropylene Piston Drum Pumps



## DESCRIPTION

These thermoplastic hand pumps are double-action piston pumps which deliver up to 17 gallons per 100 strokes. The pumps are self-priming and are built for everyday pumping at farms, construction sites and manufacturing plants.

Polypropylene pump (Model 4660-99) has excellent resistance to many organic acids, plating solutions, alcohols, and most water soluble inorganic chemicals.

**IMPORTANT:** Always refer to a chemical resistance chart to confirm compatibility. Not rated for food products.

## SPECIFICATIONS

Type.....	Piston
Flow.....	17 gallons per 100 strokes
Maximum Liquid Temperature.....	130° F (77° C)
Mounting.....	2" Bung Adapter
Inlet.....	1" NPT
Outlet.....	3/4" NPT
Spout.....	Polypropylene
Nozzle.....	Polypropylene
Pump Housing.....	Polypropylene
Piston.....	Polypropylene/Viton/Teflon
Piston Rod.....	.316 Stainless Steel
Valves.....	Polypropylene/Viton
Vacuum Breaker.....	Viton
Cover Plate.....	Polypropylene
Fastener (external).....	18-8 Stainless Steel
Ph Range.....	.4 to 11
Suction Tube.....	3-Piece Polypropylene (std.)
Gasket.....	Cork/Nitrile

hazardous conditions for the operator or equipment. TAKE NECESSARY STEPS TO PROTECT PERSONNEL AND EQUIPMENT.

Pump should only be used with liquids compatible with pump component materials. Consult PUMP CHEMICAL COMPATIBILITY CHART and PUMP SPECIFICATIONS. Also, the chemical supplier should be consulted regarding any questions of chemical compatibility, proper and safe use and handling of chemical. Misapplication of pump or use of incompatible liquids will void warranty.

### ▲ WARNING

***In order to properly use this product familiarize yourself with this pump and also with the liquid (chemical, etc.) that is going to be pumped through the unit. Although this pump is suitable for many liquids, it is not suitable for all liquids or liquids with debris or solids!***

## GENERAL SAFETY INFORMATION

### ▲ WARNING

***It is the responsibility of the user to operate the pump in conformance with OSHA rules for dispensing liquids. Pump containers should be grounded when using with flammable liquids to avoid static electricity. Pump should be washed out before usage since processing lubricants could contaminate the fluid.***

- When using a hand pump (especially when pumping flammable, combustible or hazardous liquids) follow all electrical and safety codes, as well as the United States Occupational Safety and Health Act (OSHA), most recent National Electrical Code (NEC), National Fire Protection Association, Inc.\* (NFPA) Code 30 (Flammable and Combustible Code), NFPA 56A (Standard for use of Inhalation Anesthetics), NFPA 77 (Static Electricity), NFPA 78 (Lighting Protection Code), NFPA 80 (Standard for Fire Doors and Windows), NFPA 251 (Standard Method of Fire Test of Building Construction), NFPA 704 (Identification of the Fire Hazards of Materials), other NFPA codes, local codes and ordinances, as needed in a particular application.

(\*Any of the NFPA Codes can be obtained from: National Fire Protection Association, Inc., 1 Batterymarch Park, Quincy, MA 02269, telephone 1-800-344-3555. Write or call for listing and prices.

- Know the pump application, limitations, and potential hazards. The WARNING statements indicate potentially

- Pumping hazardous, flammable, or combustible liquids should only be done in buildings, rooms, or areas suited for this purpose. (See NFPA 30, NFPA 78, NFPA 80, NFPA 251, NFPA 704, other suitable NFPA codes, OSHA, insurance companies, local codes and ordinances.)

### ▲ WARNING

***When filling cans, drums, etc. with combustible or flammable liquids, both containers (container pumping from and container pumping to), should be bonded and grounded to dissipate possible accumulations of static electricity and minimize sparks caused by static electricity. (Refer to NFPA 77 for specifics and further details.) Removal of outer garments in work areas where there may be flammable or explosive liquids, which are ignitable with low electrical energy can be fatal and/or cause property damage. (Refer to NFPA 56A and NFPA 77 for further details.)***

- The WARNING and instructions that follow pertain not only to gasoline, but to any flammable, combustible or hazardous fluid.

### ▲ WARNING

***Gasoline is a highly flammable fuel. The improper use, handling, or storage of gasoline can be dangerous. Prevent accidents by following these safety rules.***

- Use gasoline only as fuel, never as a cleaning fluid.
- Use only an approved container to hold or store gasoline. Never store gasoline in familiar containers such as milk containers or soda pop bottles.
- Store gasoline in a cool location, out of the reach of children. Never store gasoline near heat or an open flame.

# Polypropylene Piston Drum Pumps

- d. Provide a fire extinguisher nearby when working with gasoline. Be sure extinguisher is in operating condition – check the pressure gauge of indicator. Be familiar with its proper use. Consult local fire department for the correct type of extinguisher for your application. Extinguishers rated ABC by the National Fire Protection Association are appropriate for most applications.
- e. Provide positive shut-off valves on all permanent fuel supplies. Fuel lines must be of steel piping, adequately secured, and free from leaks.
- f. Provide adequate ventilation, and clean up any spills when handling or pumping flammable liquids.
- g. **POSITIVELY NO SMOKING!**
5. Do not use torches or apply fire to this pump for any reason.
6. Secure the discharge line before starting the pump. An unsecured discharge line will slip, possibly causing personal injury and/or property damage.
7. Do not over tighten nonmetallic, threaded fittings. One full turn past hand tight is usually enough to prevent leakage. Teflon® sealant tape is provided and should be used on all threaded joints, including the spout.
8. Check hoses for weak or worn conditions before each use, making certain that all connections are secure.
9. Periodically inspect pump and system components. Perform routine maintenance as required.
10. Drain all liquids from the system before servicing.
11. **PREVENT SPILLING LIQUID WHEN REMOVING PUMP FROM BARREL:**
  - a. Straighten the discharge hose and hold it below the pump discharge. Allow hose to drain into a container.
  - b. Loosen bung adapter clamp (Ref. No. 30, Figure 8).
  - c. Pull pump from bung adapter and allow suction tube to drain back to the barrel. Lay pump flat with handle up. Place container under nozzle. Operate handle until liquid is cleared from pump housing.
  - d. Allow discharge hose to drain. Place the hose nozzle in its hanger. If pump will not be installed in a new barrel, all caustic or corrosive chemicals should be flushed with fresh water internally and externally to prevent personal injury during handling.

## ▲ WARNING

**Any pump used to transfer flammable liquids must be stored in a well-ventilated area after use.**

12. Personal Safety
  - a. Wear safety glasses at all times when working with pump.
  - b. Wear a face shield, proper apparel and suitable respiratory equipment when pumping hazardous chemicals.
  - c. Keep work area clean, uncluttered, and properly lighted. Replace all unused tools and equipment.
  - d. Keep visitors at a safe distance from the work area.
  - e. Make workshop childproof with padlocks, master switches, and by removing starter keys.

## ▲ WARNING

**Failure to follow all General Safety Information can result in a fatality, personal injury and/or property damage!**

## INSTALLATION

(All Ref. Nos. correspond to the Replacement Parts List, Figure 9).

1. Screw the bung adapter (Ref. No. 30) into the drum or barrel. Be sure that the gasket (Ref. No. 29) is in place and that the threads are not over-tightened.



Figure 1

2. Install the bung adapter clamp loosely around the bung adapter.
3. Thread the reducer bushing (Ref. No. 35) and the appropriate length of suction tube (Ref. No. 33) into pump inlet. Use the Teflon sealant tape provided.

**NOTE:** The suction tube and extension tube supplied are 19½" long. The suction tube has a bevel cut at one end and is threaded at the other end. The extension tubes are threaded at both ends.

A 55 gallon drum requires one extension tube, one coupling and one suction tube, threaded together (See Figure 2). For 275 gallon tanks, thread together two extension tubes, two couplings (one of each is supplied with pump. See Replacement Parts List to order others if needed), and one suction tube.

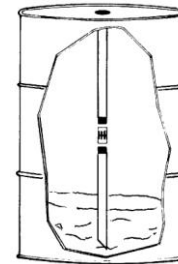

Figure 2



Figure 3

4. Install pump and tubing into bung adapter by firmly pushing straight down. Pump will snap into place (See Figure 3). Tighten the bung adapter clamp. Thread hose assembly (Ref. No. 16) and adapter or spout (Ref. No. 34) into pump housing.
5. The handle position can be changed to either the 12:00 or 6:00 positions.
  - a. Remove hairpin clip (Ref. No. 6) from the clevis pin (Ref. No. 7).
  - b. Remove clevis pin from housing to free links (Ref. No. 8). See Figure 4.

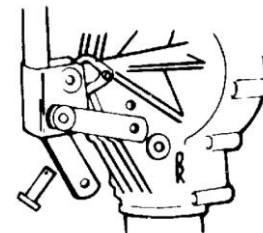

Figure 4

- c. With links clear of housing, rotate handle one-half turn to new position



Figure 5

# Polypropylene Piston Drum Pumps

- d. Install clevis pin through the links and the opposite hole in the housing.

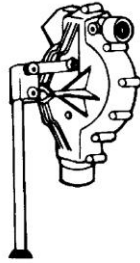

**Figure 6**

- e. Install hairpin clip through the hole in the clevis pin. Ensure that the flat washer (Ref. No. 5) is installed between the hairpin clip and the link.
6. A spout (Ref. No. 34) is provided as a standard accessory. The spout is threaded into the 3/4" discharge outlet. (Position spout downward). Wrap the threads with Teflon tape (approx. 2 turns) and screw in hand tight only.

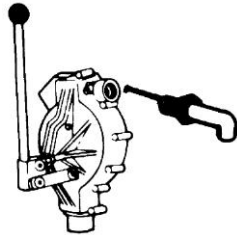

**Figure 7**

## OPERATION

- Remove hose from hanger and place nozzle in a container. Operate handle to prime the pump. Six to twelve rapid strokes are required under most conditions for priming. After the pump is primed, it will deliver about one gallon for every five strokes (17 gallons per 100 strokes).

**NOTE:** A vacuum breaker is built into the pump discharge. This prevents siphoning the drum if the hose drops from its hanger.

**NOTE:** The barrel is vented by four relief channels molded into the bung adapter. This prevents drawing a vacuum in the barrel.

## MAINTENANCE

**Important:** Periodically inspect the pump, hose assembly and suction tubes for weak or worn conditions. Make certain that all connections and fasteners are tight and secure. Perform routine maintenance as required.

- To test vacuum breaker, lay loose on ground with nozzle in a suitable container to hold the liquid. Operate the handle until liquid flows from the nozzle. Stop pumping: the hose should drain and the flow should stop. If flow continues without moving the handle, place the nozzle in its hanger to stop the flow. Inspect the vacuum breaker vent for blocking or freezing. Flush the vent with fresh water if pumping chemicals, or with cleaning product if pumping petroleum products.

## IN ORDER TO INSPECT INTERNAL PARTS, THE PUMP MUST BE DISASSEMBLED AS FOLLOWS:

- Remove hose assembly and suction tubes from the pump housing.
- Remove hex nuts (Ref. No. 21) and screws (Ref. No. 19) from the pump housing. Remove cover plate (Ref. No. 18) and gasket (Ref. No. 17), being careful not to damage the gasket.

- Remove large and small valve assemblies (Ref. Nos. 11 and 23) and inspect for broken or weak springs or damaged or clogged valves.
- Remove cotter pin (Ref. No. 6) from 1" clevis pin (Ref. No. 3) which holds handle (Ref. No. 2) to the piston rod. Remove cotter pin clip, flat washer and clevis pin (Ref. Nos. 6, 4 and 7) from links (Ref. No. 8). Remove pin from piston rod and set handle aside. Slide piston assembly (Ref. No. 25) from the housing (Ref. No. 1)
- Inspect Teflon piston (Ref. No. 27) in piston groove. It must extend 1/32" above the edge of the piston to seal properly. If the ring has worn flush with the piston edge, then the Teflon piston ring must be replaced. When replacing the Teflon piston ring, always replace the Viton O-ring (Ref. No. 26) because extended compression reduces its ability to seal.
- Inspect piston bore in housing (Ref. No. 1) for wear. Any gouging or scraping indicates the liquid being pumped contains abrasives. Replace the housing, Teflon piston ring and Viton O-ring (Ref. Nos. 1, 26 and 27) if the surfaces are gouged or worn.
- Remove the two screws (Ref. No. 9) which hold retaining plate (Ref. No. 10) to the housing. Remove plate to expose piston rod O-ring (Ref. No. 1). Replace O-ring if worn or cut.

## IN ORDER TO REASSEMBLE THE PUMP, PROCEED AS FOLLOWS:

- Install piston rod O-ring (Ref. No. 11). Install retaining plate (Ref. No. 10) with the groove facing away from the pump housing. Ensure that the Viton O-ring is inserted in the piston ring groove first and then the Teflon piston ring. Slide piston rod into housing. The Teflon piston ring may catch on the edge of the housing. To help seat the ring, turn piston slowly while pushing ring into groove with fingers. **DO NOT FORCE THE PISTON!**
- Install clevis pin (Ref. No. 3) through the piston rod and handle.
- Install the two small valve assemblies (Ref. No. 22) in the housing first and then the two large valve assemblies (Ref. No. 23). There is a small tab molded into the valve seats which fits a guide channel in the housing. This prevents installing the valve seats backwards. If these tabs are broken, please note the (lower) suction valve seats should have their springs facing each other and that the (upper) discharge valve seats should have their springs facing away from each other, when installed.
- Inspect cover plate gasket (Ref. No. 17) for damage.
- Lay cover plate and gasket assembly on the housing and install screws (Ref. No. 19) and hex nuts (Ref. No. 21). Tighten the screws and nuts firmly enough to compress the gasket.
- DO NOT OVER TIGHTEN!**
- Install the hose and suction tubes as required. Refer to Figure 3.

**For Repair Parts contact dealer where pump was purchased.**

Please provide following information:

- Model Number
- Serial Number (if any)
- Part description and number as shown in parts list

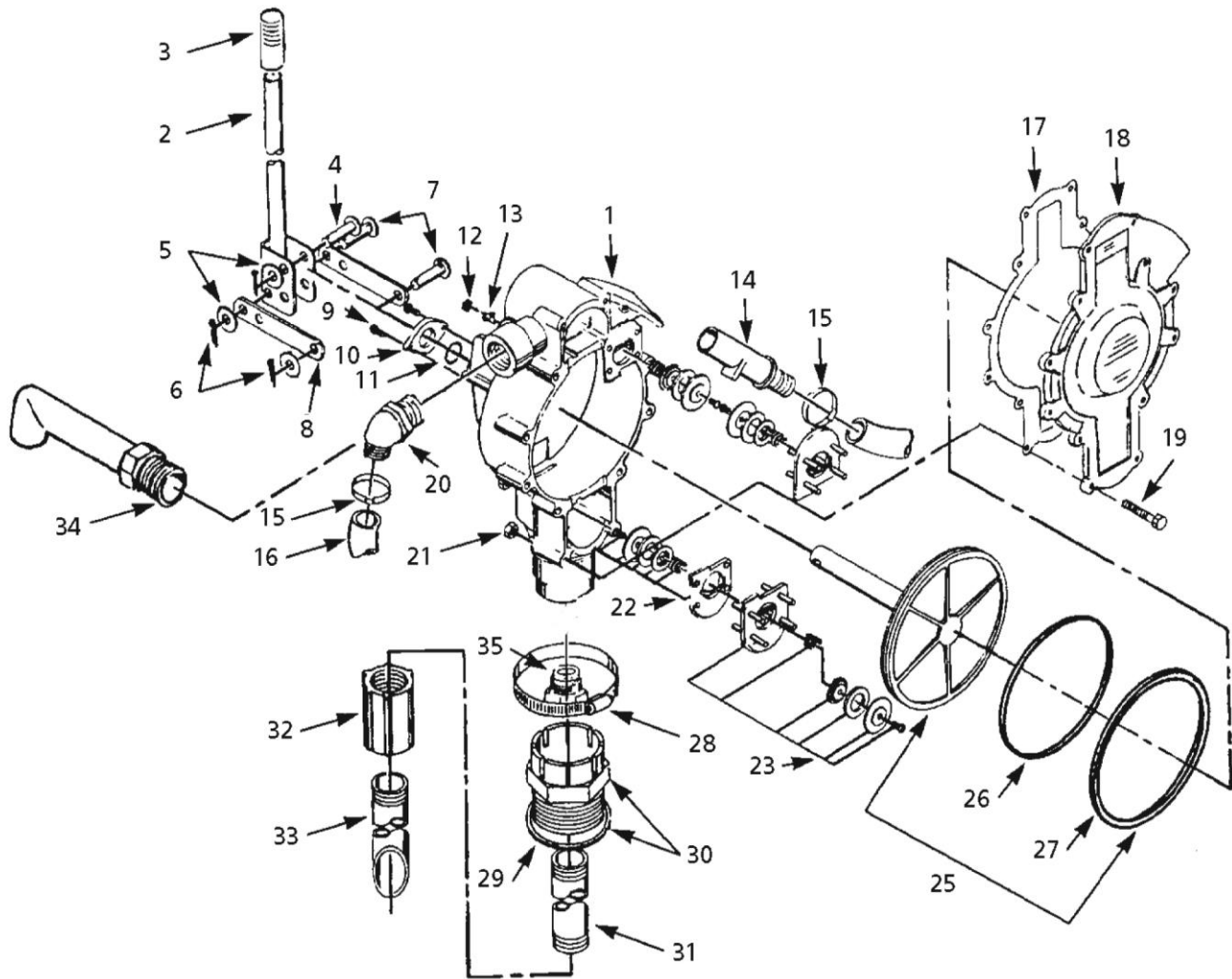

## Repair Parts List

Ref. No.	Description	Part Number for Model:	
		4660-99	Qty.
1	Pump Body	4660-001-00	1
2	Handle	4660-101-90	1
3	Grip	4660-104-00	1
4	Clevis Pin, Plated 5/16 x 1-1/8"	1766-024-00	1
5	5/16" Flat Washer	1790-003-00	3
6	Cotter Pins, Plates	1766-022-00	3
7	Clevis Pin, Plated 5/16 x 1-3/8"	1766-025-00	2
8	Link, Plated	4660-105-00	2
9	Screw, #10 x 3/4", S.S.	*	2
10	Retaining Plate	4660-050-00	1
11	Piston Rod O-Ring, Viton	2186-002-00	1
12	Vent Plug	4660-051-00	1
13	Vacuum Valve, Viton	4660-052-00	1
14	Nozzle	4660-073-00	1
15	Hose Clamp, S.S.	N/A	N/A
16	Hose, 8ft	N/A	N/A
17	Gasket, Cork/Nitrile	4660-300-00	1
18	Front Cover	4660-020-00	1
19	Hex Head Screw, 1/4-20 x 2" S.S.	*	12
20	Hose Adapter	4660-172-00	1
21	Hex Nut, 1/4-20 S.S.	*	12
22	Valve Assembly, Small	4660-070-99	2
23	Valve Assembly, Large	4660-071-99	2
25	Piston Assembly, S.S. (includes Viton O-Ring and Teflon Ring)	4660-012-99	1
26	Piston O-Ring, Viton	2186-003-00	1
27	Piston Ring, Teflon	4660-304-00	1
28	Bung Adapter Clamp, S.S.	4660-184-00	1
29	Bung Adapter Gasket, Cork/Nitrile	4660-301-00	1
30	Bung Adapter Assembly	4660-174-99	1
†31	Suction Tube Extension	4660-175-00	1
†32	Coupling	4660-177-00	1
33	Suction Tube	4660-176-00	1
34	Spout, 3/4" NPT	4660-179-00	1
35	Reducer Bushing	4660-181-00	1
◇	Teflon Tape	1696-094-00	1

(\*) Standard Hardware Item, Available Locally

(†) Pump reaches depth of 55 gallon drum with pieces provided. To reach depth of 275 gallon tank requires an addition of one (1) each of Ref. Nos. 34 and 35 (these extra parts are not supplied).

(◇) Not Shown





American Machine & Tool Co., Inc. of PA  
(herein "AMT")  
400 Spring Street  
Royersford, PA 19468  
Phone: (610) 948-3800  
Fax: (610) 948-5300  
www.amtpump.com



## General Information

**SALES POLICY:** AMT products are sold through our established Distributors. We do not sell direct to the consumer or organization not entitled to trade recognition. Therefore, possession of our catalogs and/or price list(s) does not infer an offer to sell.

**MINIMUM ORDER:** We appreciate your order, however, all orders are subject to a minimum \$35.00 net invoice charge (excluding freight). This applies to all pump and parts purchase orders.

**PRICES:** Prices are subject to change without notice. All orders accepted are subject to prices in effect at time of shipment.

**PAYMENT TERMS:** Terms, upon establishment of credit, are Net 30 days. Past due accounts may be subject to a service charge of 1.5% per month. Domestic or assignable letter of credit is required for all export trade.

**PAST DUE ACCOUNTS:** AMT reserves the right to withhold open account shipments on any past due account. Invoices are considered past due after thirty (30) days. In the interest of sound business, all orders are subject to approval of the Credit Department.

**SHIPPING INSTRUCTIONS:** All shipments will be made F.O.B. the factory. Where instructions for shipment do not appear on the order, the shipment will be made according to our best judgment. Full risk of loss (including transportation delays and losses) shall pass to the customer upon delivery of the products to the carrier at the F.O.B. point. When loss or delay occurs, primary responsibility for tracing rests with the customer. When there is LOSS or APPARENT VISIBLE DAMAGE to a shipment, when tendered for delivery, *DO NOT* give the carrier a clear receipt. Note such damage on the carrier's delivery receipt and *HAVE THE DRIVER SIGN THE RECEIPT.*

**PRODUCT REVISIONS:** AMT reserves the right to discontinue, change or improve its products or any portions thereof without being obligated to provide such a change or improvement for units sold and/or shipped prior to such a change or improvement.

**LEAD TIME:** Products designated "Quick Ship Product", also referred to as "QSP" will normally be shipped within 24 hours of receipt of a non-cancellable purchase order. Only limited quantities of "QSP" pumps are available.

**STANDARD LEAD TIME:** Lead time is two weeks for all non "QSP" product. AMT reserves the right to revise lead times as required due to availability of materials and all other causes beyond our control.

**VIP SHIPMENT:** Select AMT and IPT branded pumps are available for next day shipment for non-QSP (Quick Ship Products) items and subjected to a specific model surcharge per unit noted in the respective price book. Requires calling for availability, confirmation and a non-cancellable purchase order or credit card payment prior to shipment. The expedited shipping charges are an additional cost added separately from the VIP charges per item. AMT reserves the right to revise lead times as required due to availability of materials and all other causes beyond our control. QSP quantities are limited as determined by AMT.

ALL purchase orders must be submitted via hard copy sent to AMT customer service department by fax, EDI or e-mail.

**RETURN GOODS POLICY:** Goods shall not be returned without a return goods authorization number (RGA) issued by AMT customer service. The RGA number must be listed on the packing list. Only current model and part numbers with a valid date code may be returned (within one year from date of purchase). **A 20% restocking and packaging charge will apply to all returns. All shipping charges must be pre-paid. No exceptions.**

**ORDER CHANGES BY CUSTOMER:** Orders in process may not be changed except with written consent and may be subject to special charges.

## 12 Month Limited Warranty

### EXTENT AND DURATION OF LIMITED WARRANTY

**Coverage:** American Machine & Tool Company (herein "AMT") or IPT Pumps by Gorman-Rupp (herein "IPT") or Gorman-Rupp Industries Division of The Gorman-Rupp Company, Patterson, or the Gorman-Rupp Company (herein referred to as "G-R Unit") each individually warrants that its products and parts shall be free from defects in material and workmanship for twelve (12) months from the date of purchase by the original end user when installation is made and maintenance is performed in accordance with G-R Unit's recommendations. Wear and tear resulting from use and items normally consumed in use are not covered.

### EXCEPTIONS

( A ) This Limited Warranty shall not apply to mechanical seals in AMT or IPT pumps and the following products and parts: engines, motors, trade accessories and all other products, components, parts and materials not manufactured by the G-R Units. These items may, however, be covered by the warranties of their respective manufacturers. ( B ) This warranty does not extend to or apply to any unit which has been repaired or altered at any place other than by a G-R Unit, or by persons not expressly approved by a G-R Unit to make repairs or alterations, nor to any unit the serial number, model number or identification of which has been removed, defaced or altered. ( C ) This warranty does not extend to any product manufactured by a G-R Unit, which has been subjected to mis-use, neglect, accident, improper installation, or use in violation of instructions furnished by a G-R Unit. ( D ) Pump Kits: This warranty does not extend to any product sold by a G-R Unit unassembled as a Pump Kit. Pump Kits are warranted against defects in material and workmanship for 60 days from the date of shipment from a G-R Unit. Any Pump Kit parts deemed defective by a G-R Unit will be replaced free of charge within 60 days of shipment. Pump Kits are not returnable for credit.

### LIMITATIONS

**THE G-R UNITS' SOLE AND EXCLUSIVE WARRANTY WITH RESPECT TO THEIR PRODUCTS AND PARTS IS THIS LIMITED WARRANTY. THIS LIMITED WARRANTY IS IN LIEU OF ALL OTHER EXPRESS AND/OR IMPLIED WARRANTIES, INCLUDING IMPLIED WARRANTIES OF MERCHANTABILITY AND FITNESS FOR PARTICULAR PURPOSE.**

### EXCLUSIVE REMEDY AND DAMAGES

The sole and exclusive remedy for breach of this Warranty by a G-R Unit and the entire extent of its liability for such breach or for damages arising from the use of the products and parts covered under this Limited Warranty, shall be as follows:

- Repair or Replacement:** If inspection shows that any G-R Unit product or part covered under this Limited Warranty is defective in materials or workmanship, the G-R Unit shall repair or replace the defective or non-conforming product or part without charge, whichever the G-R Unit chooses. You must have properly maintained and used the product or part claimed to be defective in accordance with the maintenance schedule or manual, which comes with the product. No allowance will be made for labor, installation, removal, transportation or other charges incurred by you in connection with such repair or replacement.
- To obtain the above remedy:
  - Immediately notify the G-R Unit upon discovery of the claimed defect in materials or workmanship and provide the serial number or date code of the product and/or part(s) or provide the G-R Unit with the invoice or bill of sale referencing the product by no later than the expiration date of the warranty period.
  - The G-R Unit will advise whether inspection will be necessary and how whether repair or replacement will be made. If inspection by the G-R Unit is necessary, the pump or defective part must be sent freight pre-paid to the G-R Unit. Return shipment will be F.O.B. the G-R Unit's plant.
  - Return Goods Authorization Requirement:** No product will be accepted for return or replacement without the prior written authorization of the G-R Unit. Upon such authorization, and in accordance with instructions from the G-R Unit, the product will be returned to the G-R Unit, shipping charges prepaid by the Buyer.
- Damages:** The G-R Unit's liability for damages for breach of this Limited Warranty shall not exceed the amount of the purchase price of the product or part(s) in respect to which Such damages are claimed. **IN NO EVENT SHALL THE G-R UNITS BE LIABLE FOR INCIDENTAL, CONSEQUENTIAL OR SPECIAL DAMAGES FOR BREACH OF THIS LIMITED WARRANTY.**

Some states do not allow the exclusion or limitation of incidental or consequential damages, so the above limitation or exclusion may not apply to you. This Limited Warranty gives you specific legal rights, and you may also have other rights, which vary from state to state.



**A Gorman-Rupp Company**



BY  
**GORMAN-RUPP®**

[www.amtpump.com](http://www.amtpump.com)