

Please read and save this Repair Parts Manual. Read this manual and the General Operating Instructions carefully before attempting to assemble, install, operate or maintain the product described. Protect yourself and others by observing all safety information. The Safety Instructions are contained in the General Operating Instructions. Failure to comply with the safety instructions accompanying this product could result in personal injury and/or property damage! Retain instructions for future reference. AMT reserves the right to discontinue any model or change specifications at any time without incurring any obligation.

©2017 AMT Pump Company, A Subsidiary of The Gorman-Rupp Company, All Rights Reserved.

Periodic maintenance and inspection is required on all pumps to ensure proper operation. Unit must be clear of debris and sediment. Inspect for leaks and loose bolts. Failure to do so voids warranty.

Small Coolant Pumps

Suction and Immersion Models



Refer to pump manual 1808-634-00 for General Operating and Safety Instructions.

DESCRIPTION

These coolant pumps are the ideal replacement pumps for installation on machine tools. All units have cast iron construction, and feature stainless steel impellers. Pumps are equipped with a 3450 RPM motor with permanently lubricated bearings. They handle liquids with a maximum specific gravity of 1.0, maximum viscosity of 550 SSU, and maximum temperature of 180° F. For use with non-flammable liquids compatible with pump component materials. The motor on these pumps is not intended to be submerged in liquid.

IMMERSION-TYPE PUMPS:

For circulation of coolant and spraying of cutting oil in all machines, including grinders.

SUCTION-TYPE PUMPS:

May be mounted above the liquid level as well as other remote locations. Maximum suction lift is 2 feet. Pumps include a Buna-N elastomer shaft seal. For circulating coolant and spraying cutting oil in all types of machines, except grinders.

INSTALLATION

1. Install pump upright only, suction and discharge ports must be parallel to liquid surface.

NOTE: Suction-type pumps must be mounted above the liquid surface. Adding a low restriction foot valve to the suction line will enhance priming time. Both units are designed to drain away any liquid leaking past the shaft seal, to protect the motor. Provisions must be made to dispense any possible overflow.

NOTE: Immersion-type pumps must be installed with the liquid level at least 1 inch below the motor bottom.

2. Install pump and/or suction pipe a sufficient distance off the bottom of the coolant reservoir to prevent machining chips from entering the pump and damaging the pump and/or seal.
3. Install pump with a sufficient amount of liquid above the pump suction inlet to prevent drawing air into the pump.
4. Always mount the pump securely to a stable horizontal surface. Never rely on the piping to support the pump.
5. (Suction-type pumps only) Install a pipe tee in discharge line to fill the casing with liquid. Use a 90° elbow at discharge. Install Tee with long leg vertical. Vertical height of Tee from discharge port must be at least 18". Install plug in top vertical fill leg. Install discharge line into short horizontal leg of tee.

OPERATION

1. Suction-type pumps require initial priming. Do not run pump dry, damage to shaft seal will occur.

NOTE: Immersion-type pumps do not require priming and can be run dry.

2. Activate the unit. No controls are supplied with this unit.
3. Familiarize yourself and others with all controls and use of this pump. Learn how to stop pump/motor quickly in an emergency.

Maintenance

▲ WARNING

Make certain that the unit is disconnected from the power source before attempting to service or remove any component. Failure to do so could result in electrical shock.

1. Pump should be checked periodically (weekly, monthly) for proper operation, depending on hours of operation. If the system has changed since the pump was installed, or if the pump is operating noisily or erratically, then the pump should be removed and examined. It should be repaired and parts replaced as is necessary.

IMPELLER REPLACEMENT

(Refer to figure 1)

1. Disconnect the power supply.
2. Remove the pump assembly from the tank or reservoir.
3. Remove the volute or cover plate by removing the machine screws. Be careful not to damage gasket/o-ring (Suction-type pumps only).
4. Remove impeller screw and flat washer from the center of the impeller. It may be necessary to hold impeller or drive shaft to remove the impeller screw.
5. Impeller will slide off drive shaft. Some slight prying with a screwdriver may be required to break the impeller loose. Keep shims for reassembly.
6. Replace impeller by sliding onto drive shaft. Slot in impeller hub must line up with drive pin installed in drive shaft.
7. Install impeller screw and impeller washer. Spin impeller slowly by hand. If impeller rubs on machined surface, shim the impeller out in 0.010" increments until no rubbing is present. (Shims included with replacement impeller.)
8. Replace volute, or cover plate and gasket/o-ring (Suction-type pumps).
9. Secure to pump body with screws.

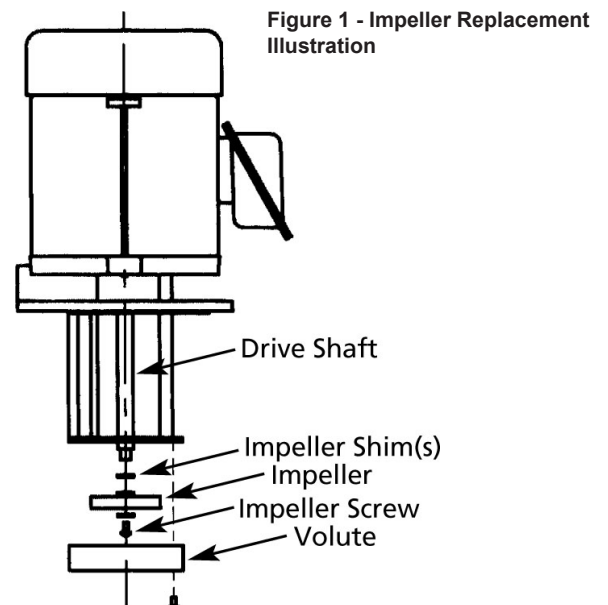

Small Coolant Pumps

SHAFT SEAL REPLACEMENT (SUCTION-TYPE PUMPS ONLY)

(Refer to figure 2)

REMOVAL OF OLD SEAL

1. Disconnect the power supply.
 2. Remove the pump assembly from the tank or reservoir.
 3. Remove impeller as described in "Impeller Replacement" section.
- NOTE: Remove fan cover and fan if motor is so equipped.
4. Remove screws holding motor body to pump body.
 5. Support pump body. Lightly tap on exposed ears of motor body until motor body is free from pump body.
 6. (Except 5340-95) Remove screws holding bearing retaining tabs to pump body.
 7. Lightly tap on end of drive shaft until lower bearing is dislodged from its bore. Remove drive shaft assembly from pump body.
 8. (5340-95 only) Remove shaft seal from its bore in pump body.
 9. (Except 5340-95) Remove seal seat from its seal cavity in pump body. Slide seal head off drive shaft.

INSTALLATION OF NEW SEAL

1. (5340-95 only) Clean seal cavity in pump body. Wet the outside diameter of the seal with soapy water. Squarely press new seal into bore until it is fully seated.
2. (Except 5340-95) Thoroughly clean seal seat cavity in pump body. Clean drive shaft.

▲ CAUTION

(Except 5340-95) *The precision lapped faces on the mechanical seal are easily damaged. Handle your replacement seal carefully. Do not touch the carbon/ ceramic seal faces.*

3. (Except 5340-95) Wet the rubber portion of the new seal seat with a light coating of soapy water. Use a clean cardboard washer of the same diameter as the seat to protect ceramic surface. With a piece of pipe or dowel rod firmly press the seal seat squarely into the bore until fully seated. Avoid scratching the white ceramic face.
4. (Except 5340-95) Dispose of cardboard washer. Check again to see that ceramic surface is free of dirt and all foreign particles.
5. (Except 5340-95) Wet inside diameter of seal head with soapy water. Slide seal head onto drive shaft until it seats.

NOTE: A short "run-in" period may be required to provide complete leakproof seal operation.

6. Replace drive shaft, take care not to damage seal when sliding drive shaft into pump body. Press drive shaft bearing into pump body.
7. (Except 5340-95) Replace bearing retaining tabs, fasten with screws.
8. Replace motor body onto drive shaft upper bearing until motor body is seated on pump body. Fasten with two screws.
9. Replace impeller as described in "Impeller Replacement" section.

NOTE: Replace fan and fan cover if motor is so equipped.

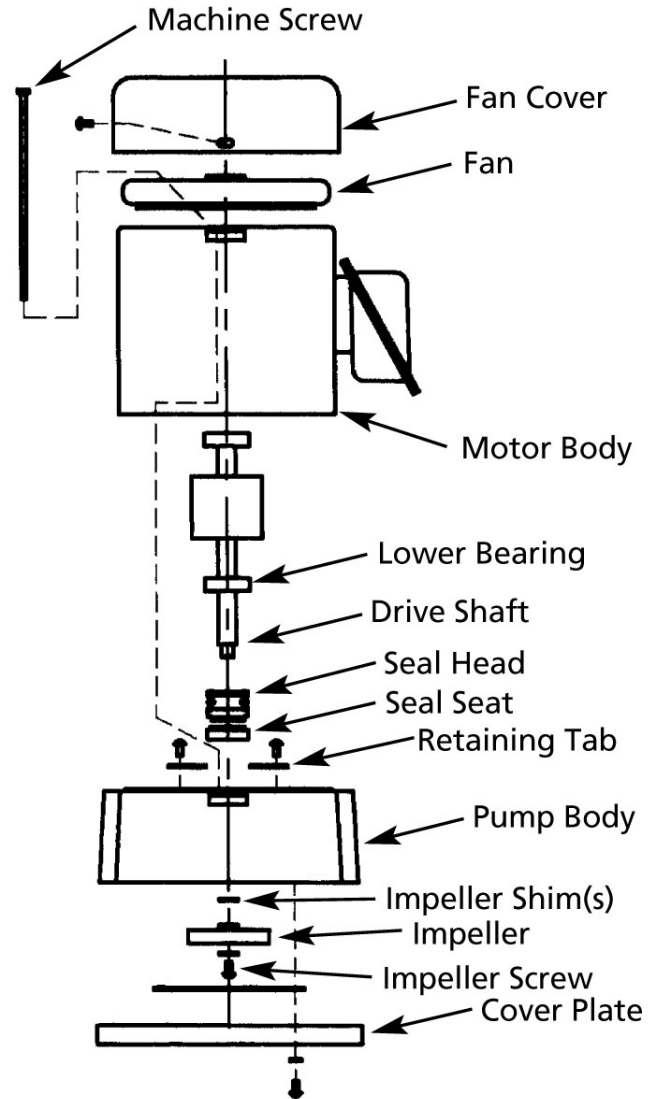

Figure 2 - Shaft Seal Replacement Illustration
(Suction-type pumps only)

Small Coolant Pumps

For Repair Parts contact dealer where pump was purchased.

Please provide following information:

-Model Number

-Serial Number (if any)

Part description and number as shown in parts list

Figure 3 - Repair Parts Illustrations for Suction-type pumps

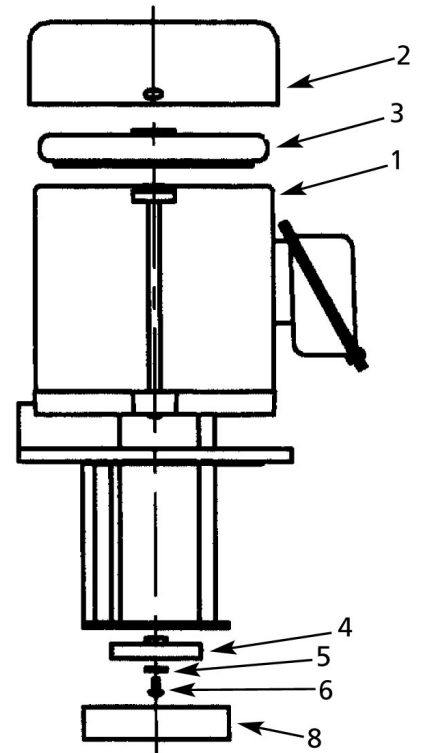
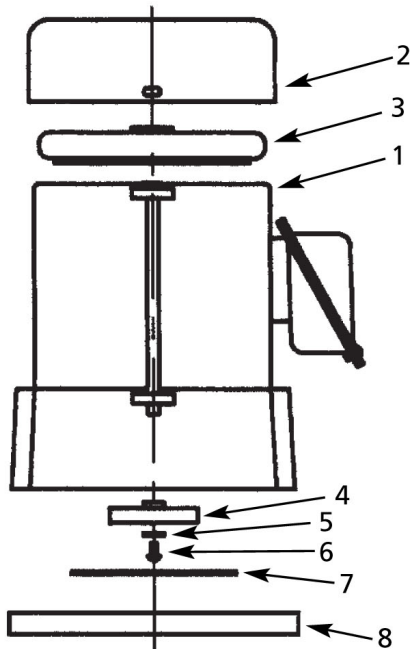

Figure 4 - Repair Parts Illustrations for Immersion-type pumps

Repair Parts List

Ref	Description	Part Number for Models										Qty
		5340,5341	5350,5351	5380,5381	5390, 5391							
No.		534A,534B	535A,535B	538A,538B	539A,539B	5360,536A	5370, 537A	5371, 537B	5400, 540A	5410, 541A	5411, 541B	
1	Motor body 1PH	5340-210-00	5350-210-00	5380-210-00	5390-210-00	-	-	-	-	-	-	1
	Motor body 3PH	5341-210-00	5351-210-00	5381-210-00	5391-210-00	5360-210-00	5370-210-00	5371-210-00	5360-210-00	5370-210-00	5371-210-00	1
2	Fan cover	-	-	-	-	5360-121-00	5360-121-00	5360-121-00	5360-121-00	5360-121-00	5360-121-00	1
3	Fan	-	-	-	-	5360-120-00	5360-120-00	5360-120-00	5360-120-00	5360-120-00	5360-120-00	1
4	Impeller SS	5340-010-01	5350-010-01	5340-010-01	5350-010-01	5360-010-01	5370-010-01	5371-010-01	5360-010-01	5370-010-01	5371-010-01	1
5	Impeller washer	5340-400-00	5350-400-00	5340-400-00	5350-400-00	5350-400-00	5350-400-00	5350-400-00	5350-400-00	5350-400-00	5350-400-00	1
6	Impeller screw	5340-401-00	5350-401-00	5340-401-00	5350-401-00	5350-401-00	5350-401-00	5350-401-00	5350-401-00	5350-401-00	5350-401-00	1
7	Cover seal	5340-301-00	5350-301-00	-	-	5360-301-00	5370-301-00	5370-301-00	-	-	-	1
8	Cover	5340-020-00	5350-020-00	5380-020-00	5390-020-00	5360-020-00	5370-020-00	5370-020-00	5400-020-00	5410-020-00	5410-020-00	1
†	Shaft seal	5340-300-00	5350-160-00	-	-	5360-160-00	5360-160-00	5360-160-00	-	-	-	1

(†) Not shown, see figure 4



AMT Pump Company
(herein "AMT")
400 Spring Street
Royersford, PA 19468
Phone: (610) 948-3800
Fax: (610) 948-5300
www.amtpump.com



General Information

SALES POLICY: AMT products are sold through our established Distributors. We do not sell direct to the consumer or organization not entitled to trade recognition. Therefore, possession of our catalogs and/or price list(s) does not infer an offer to sell.

MINIMUM ORDER: We appreciate your order, however, all orders are subject to a minimum \$35.00 net invoice charge (excluding freight). This applies to all pump and parts purchase orders.

PRICES: Prices are subject to change without notice. All orders accepted are subject to prices in effect at time of shipment.

PAYMENT TERMS: Terms, upon establishment of credit, are Net 30 days. Past due accounts may be subject to a service charge of 1.5% per month. Domestic or assignable letter of credit is required for all export trade.

PAST DUE ACCOUNTS: AMT reserves the right to withhold open account shipments on any past due account. Invoices are considered past due after thirty (30) days. In the interest of sound business, all orders are subject to approval of the Credit Department.

SHIPPING INSTRUCTIONS: All shipments will be made F.O.B. the factory. Where instructions for shipment do not appear on the order, the shipment will be made according to our best judgment. Full risk of loss (including transportation delays and losses) shall pass to the customer upon delivery of the products to the carrier at the F.O.B. point. When loss or delay occurs, primary responsibility for tracing rests with the customer. When there is LOSS or APPARENT VISIBLE DAMAGE to a shipment, when tendered for delivery, **DO NOT** give the carrier a clear receipt. Note such damage on the carrier's delivery receipt and **HAVE THE DRIVER SIGN THE RECEIPT.**

PRODUCT REVISIONS: AMT reserves the right to discontinue, change or improve its products or any portions thereof without being obligated to provide such a change or improvement for units sold and/or shipped prior to such a change or improvement.

12 Month Limited Warranty

EXTENT AND DURATION OF LIMITED WARRANTY

Coverage: AMT Pump Company (herein "AMT") or IPT Pumps by Gorman-Rupp (herein "IPT") or Gorman-Rupp Industries Division of The Gorman-Rupp Company, Patterson, or the Gorman-Rupp Company (herein referred to as "G-R Unit") each individually warrants that its products and parts shall be free from defects in material and workmanship for twelve (12) months from the date of purchase by the original end user when installation is made and maintenance is performed in accordance with G-R Unit's recommendations. Wear and tear resulting from use and items normally consumed in use are not covered.

EXCEPTIONS

(A) This Limited Warranty shall not apply to mechanical seals in AMT or IPT pumps and the following products and parts: engines, motors, trade accessories and all other products, components, parts and materials not manufactured by the G-R Units. These items may, however, be covered by the warranties of their respective manufacturers. (B) This warranty does not extend to or apply to any unit which has been repaired or altered at any place other than by a G-R Unit, or by persons not expressly approved by a G-R Unit to make repairs or alterations, nor to any unit the serial number, model number or identification of which has been removed, defaced or altered. (C) This warranty does not extend to any product manufactured by a G-R Unit, which has been subjected to mis-use, neglect, accident, improper installation, or use in violation of instructions furnished by a G-R Unit. (D) Pump Kits: This warranty does not extend to any product sold by a G-R Unit unassembled as a Pump Kit. Pump Kits are warranted against defects in material and workmanship for 60 days from the date of shipment from a G-R Unit. Any Pump Kit parts deemed defective by a G-R Unit will be replaced free of charge within 60 days of shipment. Pump Kits are not returnable for credit.

LIMITATIONS

THE G-R UNITS' SOLE AND EXCLUSIVE WARRANTY WITH RESPECT TO THEIR PRODUCTS AND PARTS IS THIS LIMITED WARRANTY. THIS LIMITED WARRANTY IS IN LIEU OF ALL OTHER EXPRESS AND/OR IMPLIED WARRANTIES, INCLUDING IMPLIED WARRANTIES OF MERCHANTABILITY AND FITNESS FOR PARTICULAR PURPOSE.

EXCLUSIVE REMEDY AND DAMAGES

The sole and exclusive remedy for breach of this Warranty by a G-R Unit and the entire extent of its liability for such breach or for damages arising from the use of the products and parts covered under this Limited Warranty, shall be as follows:

LEAD TIME: Products designated "Quick Ship Product", also referred to as "QSP" will normally be shipped within 24 hours of receipt of a non-cancellable purchase order. Only limited quantities of "QSP" pumps are available.

STANDARD LEAD TIME: Lead time is two weeks for all non "QSP" product. AMT reserves the right to revise lead times as required due to availability of materials and all other causes beyond our control.

VIP SHIPMENT: Select AMT and IPT branded pumps are available for next day shipment for non-QSP (Quick Ship Products) items and subjected to a specific model surcharge per unit noted in the respective price book. Requires calling for availability, confirmation and a non-cancellable purchase order or credit card payment prior to shipment. The expedited shipping charges are an additional cost added separately from the VIP charges per item. AMT reserves the right to revise lead times as required due to availability of materials and all other causes beyond our control. QSP quantities are limited as determined by AMT.

ALL purchase orders must be submitted via hard copy sent to AMT customer service department by fax, EDI or e-mail.

RETURN GOODS POLICY: Goods shall not be returned without a return goods authorization number (RGA) issued by AMT customer service. The RGA number must be listed on the packing list. Only current model and part numbers with a valid date code may be returned (within one year from date of purchase). **A 20% restocking and packaging charge will apply to all returns. All shipping charges must be pre-paid. No exceptions.**

ORDER CHANGES BY CUSTOMER: Orders in process may not be changed except with written consent and may be subject to special charges.

- 1. Repair or Replacement:** If inspection shows that any G-R Unit product or part covered under this Limited Warranty is defective in materials or workmanship, the G-R Unit shall repair or replace the defective or non-conforming product or part without charge, whichever the G-R Unit chooses. You must have properly maintained and used the product or part claimed to be defective in accordance with the maintenance schedule or manual, which comes with the product. No allowance will be made for labor, installation, removal, transportation or other charges incurred by you in connection with such repair or replacement.
- 2. To obtain the above remedy:**
 - A.** Immediately notify the G-R Unit upon discovery of the claimed defect in materials or workmanship and provide the serial number or date code of the product and/or part(s) or provide the G-R Unit with the invoice or bill of sale referencing the product by no later than the expiration date of the warranty period.
 - B.** The G-R Unit will advise whether inspection will be necessary and how whether repair or replacement will be made. If inspection by the G-R Unit is necessary, the pump or defective part must be sent freight pre-paid to the G-R Unit. Return shipment will be F.O.B. the G-R Unit's plant.
 - C. Return Goods Authorization Requirement:** No product will be accepted for return or replacement without the prior written authorization of the G-R Unit. Upon such authorization, and in accordance with instructions from the G-R Unit, the product will be returned to the G-R Unit, shipping charges prepaid by the Buyer.
- 3. Damages:** The G-R Unit's liability for damages for breach of this Limited Warranty shall not exceed the amount of the purchase price of the product or part(s) in respect to which Such damages are claimed. **IN NO EVENT SHALL THE G-R UNITS BE LIABLE FOR INCIDENTAL, CONSEQUENTIAL OR SPECIAL DAMAGES FOR BREACH OF THIS LIMITED WARRANTY.**

Some states do not allow the exclusion or limitation of incidental or consequential damages, so the above limitation or exclusion may not apply to you. This Limited Warranty gives you specific legal rights, and you may also have other rights, which vary from state to state.