

Please read and save this Repair Parts Manual. Read this manual and the General Operating Instructions carefully before attempting to assemble, install, operate or maintain the product described. Protect yourself and others by observing all safety information. The Safety Instructions are contained in the General Operating Instructions. Failure to comply with the safety instructions accompanying this product could result in personal injury and/or property damage! Retain instructions for future reference. AMT reserves the right to discontinue any model or change specifications at any time without incurring any obligation.

©2013 American Machine & Tool Co., Inc. of PA, A Subsidiary of The Gorman-Rupp Company, All Rights Reserved.

Periodic maintenance and inspection is required on all pumps to insure proper operation. Unit must be clear of debris and sediment. Inspect for leaks and loose bolts. Failure to do so voids warranty.

1-1/2 Inch Self-Priming Centrifugal Pumps



Refer to pump manual 1808-634-00 for General Operating and Safety Instructions.

DESCRIPTION

These self-priming centrifugal pumps are used for continuous transfer pumping of chemicals from tanks and sumps, and in chemical process and batch lines, waste water treatment and agricultural pumping applications.

Pumps self-prime (after filling pump casing) to 6 feet suction lift and will handle liquids with entrapped gases. Maximum viscosity is 100 SSU. Casing working pressure to 75 psi (517 kPa). For use with nonflammable, nonabrasive liquids compatible with pump component materials.

▲ WARNING

All units are for use with non-flammable, non-abrasive liquids compatible with pump component materials.

STAINLESS STEEL UNITS (-98)

Stainless steel pumps will handle many acids, alkalis, caustics, solvents, brines and other fluids compatible with 300 series stainless steel body and impeller, and Teflon mechanical seal (comprised of ceramic seat, carbon head and 316 stainless steel spring). Handle liquids from 40° to 250° F (4° to 121° C).

BRONZE UNITS (-97)

Bronze units handle many acids and organic material compatible with bronze body, stainless steel impeller, and Viton mechanical seal (comprised of ceramic seat, carbon head and stainless steel spring). Handle liquids from 40° to 200° F (4° to 93° C).

MAINTENANCE

▲ WARNING

Make certain that power source is disconnected before attempting to service or disassemble any components! If power disconnect is out of sight, lock it in open position and tag to prevent application of power

MECHANICAL SEAL REPLACEMENT

Refer to Figures 1, 2 and 3.

IMPORTANT: Always replace both seal seat (Ref. No. 11) and seal head (Ref. No. 10) to insure proper mating of components! It is recommended that impeller seal (Ref. No. 14) also be replaced when replacing shaft seal.

1. Unthread fasteners (Ref. No. 7) and remove casing (Ref. No. 16) and casing seal (Ref. No. 8).
2. Unscrew impeller fastener (Ref. No. 15) from motor shaft (fastener unscrews CCW looking at motor shaft).

NOTE: Some motors use an open end 7/16" wrench across

flats on rear of motor shaft (remove bearing cap for access) to prevent shaft from turning. Other motor shafts have a screw-driver slot instead of flats.

3. Unscrew impeller (Ref. No. 13) from motor shaft. Remove the impeller seal. Also, remove shims (Ref. No. 9) DO NOT LOSE SHIMS.
4. Pry seal seat from recess of impeller. Use caution so as not to damage or remove seal seat pin (Ref. No. 12) on Teflon seal equipped units.
5. Remove the adapter and casing cover (Ref. Nos. 3 and 6) by unthreading fasteners (Ref. Nos. 4 and 5).
6. Press seal head from rear of casing cover.
7. Clean casing cover and impeller seal recesses and motor shaft. Make certain all surfaces are perfectly clean before installing new seal parts.

▲ CAUTION

Handle seal parts with extreme caution and keep them clean. Do not touch polished seal faces with your hands. Do not apply lubricants on seal faces. This could cause a leak or premature seal failure.

8. Apply a light coat of sealing compound to new seal head (See Figure 2) and press it into casing cover recess using proper size tube or installation tool (see Figure 3). DO NOT press on carbon face or top of metal cup of the seal head. Install using flange only.
9. Slide adapter and casing cover assembly onto motor mounting face. Attach with fasteners.
10. Press new seal seat squarely into impeller recess. Align slot in seal seat with seal seat pin on Teflon equipped units. Avoid scratching polished surface.

NOTE: Use a soft, clean piece of cloth on seal seat face when installing to prevent marring.

11. Replace any shim washers which may have been removed in disassembly (see SHIM ADJUSTMENT). Screw the impeller back in place, tightening until it is firmly seated.
12. Install impeller seal and install and tighten impeller lock nut.
13. Reinstall seal on casing cover rabbet. Remount casing with fasteners.

1-1/2 Inch Self-Priming Centrifugal Pumps

NOTE: Always flush pump thoroughly before use so as not to contaminate liquid being pumped. If impeller is replaced, seal assembly should also be replaced as seal is usually damaged in disassembly. Also replace impeller washer.

SHIM ADJUSTMENT

When installing a replacement impeller (Ref. No. 13) or motor (Ref. No. 1), it may be necessary to adjust number of shims (Ref. No. 9) to ensure proper running clearance between impeller and casing. Proceed as follows:

NOTE: A proper running clearance is less than 0.010" (face of impeller to mating face of casing).

1. For impeller replacement, add one (1) shim (thinnest 0.010") in addition to those removed originally.
2. For motor replacement, add two (2) shims (both 0.010") in addition to those removed during disassembly.

3. Reassemble pump as described in Steps 11, 12 and 13.

IMPORTANT: Ensure that casing is snugly in place and check shaft to make sure it is turning freely. (Use 7/16" wrench or screwdriver to turn shaft). If it turns freely, check to ensure that adapter, casing cover and casing are fitted metal-to-metal where they meet on outside. If they are not metal-to-metal, tighten fasteners (Ref. Nos. 1, 5 and 7) and recheck shaft for free turning. Tighten carefully, turning shaft while tightening so that motor bearings are not damaged in the event that too many shims were installed. If shaft seizes before fasteners are completely tight, disassembly pump and remove one (1) shim (thinnest 0.010") and repeat reassembly.

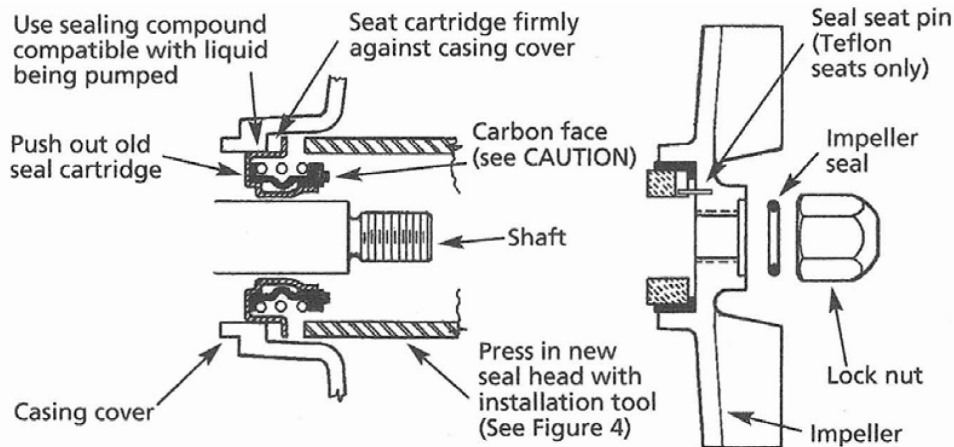

Figure 1 - Mechanical Seal Replacement (Teflon seal shown)

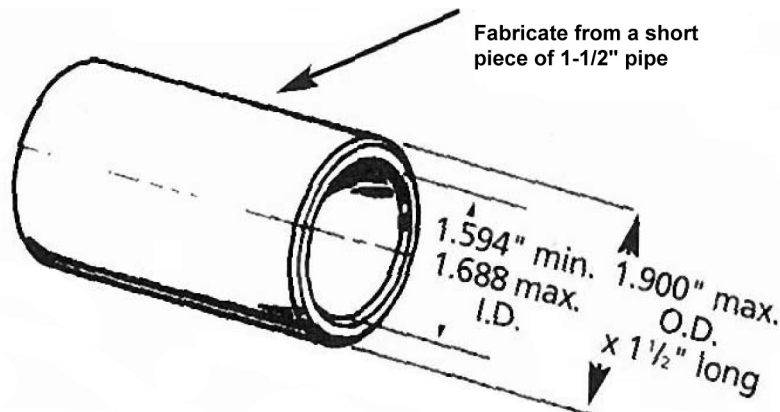

Figure 2 - Seal Installation Tool

1-1/2 Inch Self-Priming Centrifugal Pumps

For Repair Parts contact dealer where pump was purchased.

Please provide following information:

-Model Number

-Serial Number (if any)

Part description and number as shown in parts list

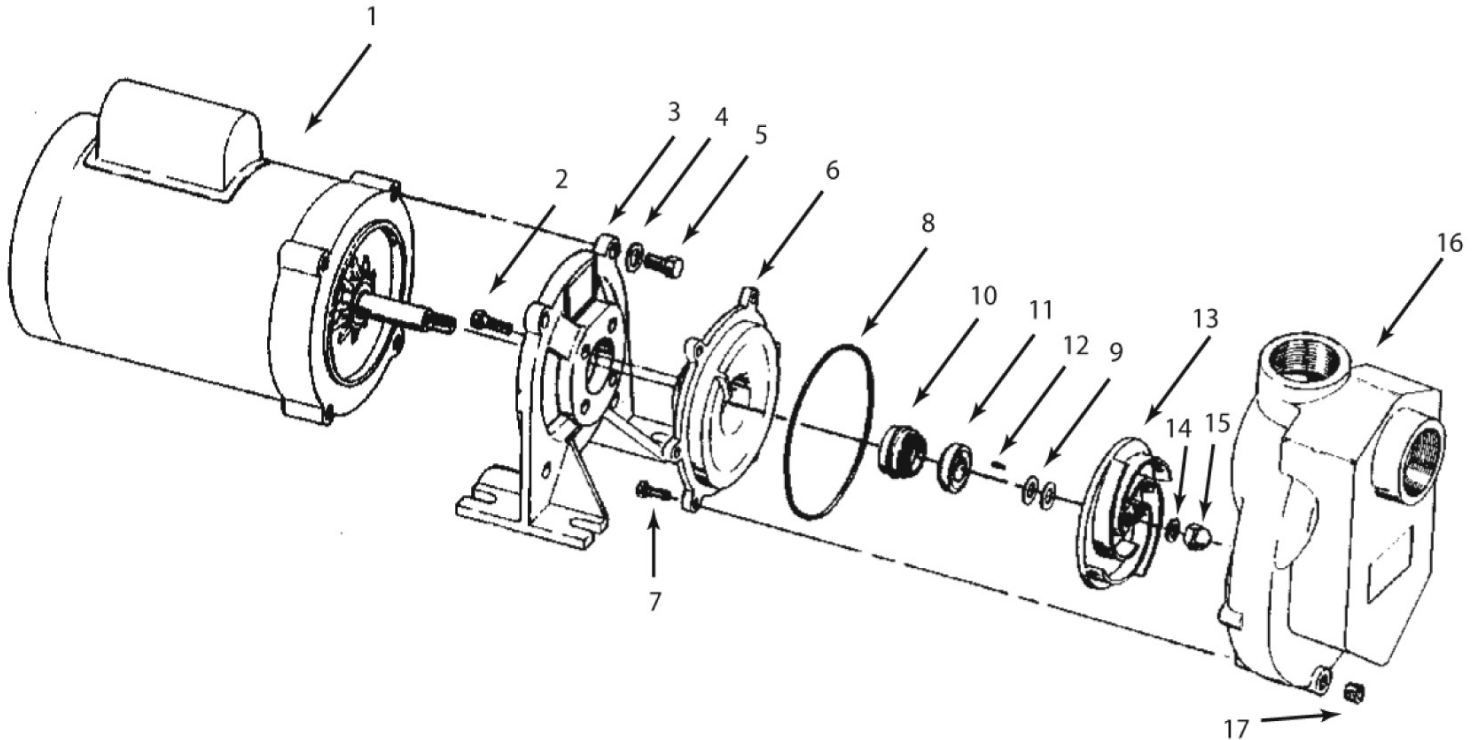

Figure 3 - Repair Parts Illustrations

Repair Parts List

Ref. No.	Description	Part Number for Models			Qty
		3/4 HP 3890 3892	1.5 HP 3891 3893	2 HP 389A 3894	
1	Motor - 1 Phase TEFC	1626-302-00	1626-304-00	1626-305-00	1
	Motor - 3 Phase TEFC	1626-308-00	1626-310-00	1626-311-00	
2	Fastener	*	*	*	4
3	Adapter	3890-032-09	3890-032-09	3890-032-09	1
4	Washer	*	*	*	4
5	Fastener	*	*	*	4
6	Casing Cover - Stainless Steel	2105-003-01	2105-003-01	2105-003-01	1
	Casing Cover - Bronze	2105-017-01	2105-017-01	2105-017-01	
7	Fastener	*	*	*	6
8	Casing Seal - Teflon (standard on Stainless Steel)	2105-004-00	2105-004-00	2105-044-00	1
	Casing Seal - Viton (standard on Bronze)	2105-023-00	2105-023-00	2105-023-00	1
9	Impeller Shim Kit	1806-044-90	1806-044-90	1806-044-90	1
10 & 11	Shaft Seal - Teflon (standard on Stainless Steel)	1641-162-91	1641-162-91	1641-162-91	1
	Shaft Seal - Viton (standard on Bronze)	1641-162-90	1641-162-90	1641-162-90	
12	Pin (used for Teflon seals ONLY)	1652-006-00	1652-006-00	1652-006-00	1
13	Impeller	2105-006-01	2105-007-02	2105-009-01	1
14	Impeller Seal - Teflon (standard on Stainless Steel)	2105-031-00	2105-031-00	2105-031-00	1
	Impeller Seal - Viton (standard on Bronze)	2105-037-00	2105-037-00	2105-037-00	
15	Impeller Fastener	1784-001-00	1784-001-00	1784-001-00	1
16	Casing - Stainless Steel	2105-001-01	2105-001-01	2105-001-01	1
	Casing - Bronze	2105-016-01	2105-016-01	2105-016-01	
17	Pipe Plug	*	*	*	1
(*)	Standard hardware item, available locally.				



American Machine & Tool Co., Inc. of PA
(herein "AMT")
400 Spring Street
Royersford, PA 19468
Phone: (610) 948-3800
Fax: (610) 948-5300
www.amtpump.com



General Information

SALES POLICY: AMT products are sold through our established Distributors. We do not sell direct to the consumer or organization not entitled to trade recognition. Therefore, possession of our catalogs and/or price list(s) does not infer an offer to sell.

MINIMUM ORDER: We appreciate your order, however, all orders are subject to a minimum \$35.00 net invoice charge (excluding freight). This applies to all pump and parts purchase orders.

PRICES: Prices are subject to change without notice. All orders accepted are subject to prices in effect at time of shipment.

PAYMENT TERMS: Terms, upon establishment of credit, are Net 30 days. Past due accounts may be subject to a service charge of 1.5% per month. Domestic or assignable letter of credit is required for all export trade.

PAST DUE ACCOUNTS: AMT reserves the right to withhold open account shipments on any past due account. Invoices are considered past due after thirty (30) days. In the interest of sound business, all orders are subject to approval of the Credit Department.

SHIPPING INSTRUCTIONS: All shipments will be made F.O.B. the factory. Where instructions for shipment do not appear on the order, the shipment will be made according to our best judgment. Full risk of loss (including transportation delays and losses) shall pass to the customer upon delivery of the products to the carrier at the F.O.B. point. When loss or delay occurs, primary responsibility for tracing rests with the customer. When there is LOSS or APPARENT VISIBLE DAMAGE to a shipment, when tendered for delivery, *DO NOT* give the carrier a clear receipt. Note such damage on the carrier's delivery receipt and *HAVE THE DRIVER SIGN THE RECEIPT.*

PRODUCT REVISIONS: AMT reserves the right to discontinue, change or improve its products or any portions thereof without being obligated to provide such a change or improvement for units sold and/or shipped prior to such a change or improvement.

LEAD TIME: Products designated "Quick Ship Product", also referred to as "QSP" will normally be shipped within 24 hours of receipt of a non-cancellable purchase order. Only limited quantities of "QSP" pumps are available.

STANDARD LEAD TIME: Lead time is two weeks for all non "QSP" product. AMT reserves the right to revise lead times as required due to availability of materials and all other causes beyond our control.

VIP SHIPMENT: Select AMT and IPT branded pumps are available for next day shipment for non-QSP (Quick Ship Products) items and subjected to a specific model surcharge per unit noted in the respective price book. Requires calling for availability, confirmation and a non-cancellable purchase order or credit card payment prior to shipment. The expedited shipping charges are an additional cost added separately from the VIP charges per item. AMT reserves the right to revise lead times as required due to availability of materials and all other causes beyond our control. QSP quantities are limited as determined by AMT.

ALL purchase orders must be submitted via hard copy sent to AMT customer service department by fax, EDI or e-mail.

RETURN GOODS POLICY: Goods shall not be returned without a return goods authorization number (RGA) issued by AMT customer service. The RGA number must be listed on the packing list. Only current model and part numbers with a valid date code may be returned (within one year from date of purchase). **A 20% restocking and packaging charge will apply to all returns. All shipping charges must be pre-paid. No exceptions.**

ORDER CHANGES BY CUSTOMER: Orders in process may not be changed except with written consent and may be subject to special charges.

12 Month Limited Warranty

EXTENT AND DURATION OF LIMITED WARRANTY

Coverage: American Machine & Tool Company (herein "AMT") or IPT Pumps by Gorman-Rupp (herein "IPT") or Gorman-Rupp Industries Division of The Gorman-Rupp Company, Patterson, or the Gorman-Rupp Company (herein referred to as "G-R Unit") each individually warrants that its products and parts shall be free from defects in material and workmanship for twelve (12) months from the date of purchase by the original end user when installation is made and maintenance is performed in accordance with G-R Unit's recommendations. Wear and tear resulting from use and items normally consumed in use are not covered.

EXCEPTIONS

(A) This Limited Warranty shall not apply to mechanical seals in AMT or IPT pumps and the following products and parts: engines, motors, trade accessories and all other products, components, parts and materials not manufactured by the G-R Units. These items may, however, be covered by the warranties of their respective manufacturers. (B) This warranty does not extend to or apply to any unit which has been repaired or altered at any place other than by a G-R Unit, or by persons not expressly approved by a G-R Unit to make repairs or alterations, nor to any unit the serial number, model number or identification of which has been removed, defaced or altered. (C) This warranty does not extend to any product manufactured by a G-R Unit, which has been subjected to mis-use, neglect, accident, improper installation, or use in violation of instructions furnished by a G-R Unit. (D) Pump Kits: This warranty does not extend to any product sold by a G-R Unit unassembled as a Pump Kit. Pump Kits are warranted against defects in material and workmanship for 60 days from the date of shipment from a G-R Unit. Any Pump Kit parts deemed defective by a G-R Unit will be replaced free of charge within 60 days of shipment. Pump Kits are not returnable for credit.

LIMITATIONS

THE G-R UNITS' SOLE AND EXCLUSIVE WARRANTY WITH RESPECT TO THEIR PRODUCTS AND PARTS IS THIS LIMITED WARRANTY. THIS LIMITED WARRANTY IS IN LIEU OF ALL OTHER EXPRESS AND/OR IMPLIED WARRANTIES, INCLUDING IMPLIED WARRANTIES OF MERCHANTABILITY AND FITNESS FOR PARTICULAR PURPOSE.

EXCLUSIVE REMEDY AND DAMAGES

The sole and exclusive remedy for breach of this Warranty by a G-R Unit and the entire extent of its liability for such breach or for damages arising from the use of the products and parts covered under this Limited Warranty, shall be as follows:

- Repair or Replacement:** If inspection shows that any G-R Unit product or part covered under this Limited Warranty is defective in materials or workmanship, the G-R Unit shall repair or replace the defective or non-conforming product or part without charge, whichever the G-R Unit chooses. You must have properly maintained and used the product or part claimed to be defective in accordance with the maintenance schedule or manual, which comes with the product. No allowance will be made for labor, installation, removal, transportation or other charges incurred by you in connection with such repair or replacement.
- To obtain the above remedy:
 - Immediately notify the G-R Unit upon discovery of the claimed defect in materials or workmanship and provide the serial number or date code of the product and/or part(s) or provide the G-R Unit with the invoice or bill of sale referencing the product by no later than the expiration date of the warranty period.
 - The G-R Unit will advise whether inspection will be necessary and how whether repair or replacement will be made. If inspection by the G-R Unit is necessary, the pump or defective part must be sent freight pre-paid to the G-R Unit. Return shipment will be F.O.B. the G-R Unit's plant.
 - Return Goods Authorization Requirement:** No product will be accepted for return or replacement without the prior written authorization of the G-R Unit. Upon such authorization, and in accordance with instructions from the G-R Unit, the product will be returned to the G-R Unit, shipping charges prepaid by the Buyer.
- Damages:** The G-R Unit's liability for damages for breach of this Limited Warranty shall not exceed the amount of the purchase price of the product or part(s) in respect to which Such damages are claimed. **IN NO EVENT SHALL THE G-R UNITS BE LIABLE FOR INCIDENTAL, CONSEQUENTIAL OR SPECIAL DAMAGES FOR BREACH OF THIS LIMITED WARRANTY.**

Some states do not allow the exclusion or limitation of incidental or consequential damages, so the above limitation or exclusion may not apply to you. This Limited Warranty gives you specific legal rights, and you may also have other rights, which vary from state to state.



A Gorman-Rupp Company



BY
GORMAN-RUPP®

www.amtpump.com