

Please read and save this Repair Parts Manual. Read this manual and the General Operating Instructions carefully before attempting to assemble, install, operate or maintain the product described. Protect yourself and others by observing all safety information. The Safety Instructions are contained in the General Operating Instructions. Failure to comply with the safety instructions accompanying this product could result in personal injury and/or property damage! Retain instructions for future reference. AMT reserves the right to discontinue any model or change specifications at any time without incurring any obligation.

©2017 AMT Pump Company, A Subsidiary of The Gorman-Rupp Company, All Rights Reserved.

Periodic maintenance and inspection is required on all pumps to insure proper operation. Unit must be clear of debris and sediment. Inspect for leaks and loose bolts. Failure to do so voids warranty.

# Self-Priming Centrifugal Pedestal Pumps

## High Volume Dewatering Cast Iron and Stainless Steel Models



Refer to pump manual 1808-635-00 for General Operating and Safety Instructions.

### DESCRIPTION

These self-priming (to 20 ft. lift) centrifugal pumps are heavy-duty units designed for the high volume liquid transfer involving irrigation, dewatering, lawn sprinkling, etc. . Pumps are equipped with a flapper valve (to eliminate re-priming after each use) and a clog-resistant impeller which enables the pumps to handle semi-solids (up to 3/8" dia.) and sediment laden liquids. Handle liquids from 40° to 180° F (4° to 82° C). For use with non-flammable, non-abrasive liquids compatible with pump component materials.

Units can be installed with direct-coupling drive or pulley drive and can be driven by electric motor or gasoline engine.

For further pump information, see Specifications, Performance and Pulley Drive Charts.

## Specifications

| Description          | Model 2820-98  | Model 2820-99   | Model 282P-95  | Model 2760-99   | Model 2761-99  |
|----------------------|--|---|--|---|--|
| Suction Inlet        | 1 1/2" NPT   | 1 1/2" NPT  | 1 1/2" NPT   | 2" NPT  | 2" NPT   |
| Discharge Outlet     | 1 1/2" NPT   | 1 1/2" NPT  | 1 1/2" NPT   | 2" NPT  | 2" NPT   |
| Shaft Diameter       | 3/4"   | 5/8"  | 3/4"   | 3/4"  | 3/4"   |
| Keyway               | 3/16" x 3/32" x 1 1/8"   | 3/16" x 3/32" x 3/4"  | 3/16" x 3/32" x 1 1/8"   | 3/16" x 3/32" x 1 1/8"  | 3/16" x 3/32" x 1 1/8"   |
| Dimensions (overall) | 14 1/2" L x 7 3/8" W x 10" H                                       | 10 1/2" L x 7 3/8" W x 10 1/8" H                                    | 14 1/2" L x 7 3/8" W x 10" H                                       | 15 3/4" L x 7 3/8" W x 10 7/8" H                                    | 15 3/4" L x 7 3/8" W x 10-15 1/16" H                               |
| Weight (approximate) | 33 lbs.  | 32 lbs.   | 38 lbs.  | 44 lbs.   | 46 lbs.  |
| Basic Construction   | Stainless Steel  | Cast Iron   | Cast Iron  | Cast Iron   | Stainless Steel  |
| Seal                 | Viton elastomers, ceramic seat, carbon head, and stainless spring. | Buna-N elastomers, ceramic seat, carbon head, and stainless spring. | Viton elastomers, ceramic seat, carbon head, and stainless spring. | Buna-N elastomers, ceramic seat, carbon head, and stainless spring. | Viton elastomers, ceramic seat, carbon head, and stainless spring. |

**IMPORTANT:** Find desired pump speed in accordance with the performance chart. Select driver with the proper RPM and corresponding pulley size. The chart covers both models.

### Pulley Drive Chart

| Pump Speed RPM | Motor Speed | * Pulley Diameter Motor | Pump   |
|----------------|-------------|-------------------------|--------|
| 1725           | 1725 RPM    | 3"                      | 3"     |
|                | 3450 RPM    | 2 1/2"                  | 5"     |
| 2300           | 1725 RPM    | 4"                      | 3"     |
|                | 3450 RPM    | 3"                      | 4 1/2" |
| 2800           | 1725 RPM    | 4"                      | 2 1/2" |
|                | 3450 RPM    | 2 1/2"                  | 3"     |
| 3450           | 1725 RPM    | 6"                      | 3"     |
|                | 3450 RPM    | 3"                      | 3"     |

(\* ) All A Section, Single Groove

# Self-Priming Centrifugal Pedestal Pumps

## High Volume Dewatering Cast Iron and Stainless Steel Models

### Performance Chart

| Model    | Pump RPM | Min. Motor Required | GPH at Total Head in Feet |       |       |       |       |       |       |       |     | *Max. Head |
|----------|----------|---------------------|---------------------------|-------|-------|-------|-------|-------|-------|-------|-----|------------|
|          |          |                     | 10'                       | 20'   | 30'   | 40'   | 50'   | 60'   | 70'   | 80'   | 90' |            |
| 2820-99, | 1725     | 1/2 HP              | 2,580                     | 600   | -     | -     | -     | -     | -     | -     | -   | 22 ft.     |
| 2820-98, | 2300     | 3/4 HP              | 4,200                     | 3,000 | 1,260 | -     | -     | -     | -     | -     | -   | 34 ft.     |
| 282P-95  | 2800     | 1 HP                | -                         | 4,380 | 3,600 | 2,400 | 600   | -     | -     | -     | -   | 52 ft.     |
|          | 3450     | 2 HP                | -                         | 6,360 | 5,880 | 5,280 | 4,500 | 3,600 | 2,400 | 1,200 | -   | 88 ft.     |
| 2760-99, | 1725     | 1/2 HP              | 3,120                     | -     | -     | -     | -     | -     | -     | -     | -   | 16 ft.     |
| 2761-99  | 2300     | 1 HP                | 5,040                     | 3,540 | 1,440 | -     | -     | -     | -     | -     | -   | 33 ft.     |
|          | 2800     | 1 1/2 HP            | -                         | 5,650 | 4,440 | 2,940 | 600   | -     | -     | -     | -   | 52 ft.     |
|          | 3450     | 3 HP                | -                         | 8,100 | 7,320 | 6,000 | 5,100 | 4,260 | 3,000 | 1,260 | -   | 84 ft.     |

(\*) Shut-off; to convert to psi, divide by 2.31.

### MAINTENANCE

#### ▲ WARNING

Make certain that unit is disconnected from power source before attempting to service or remove any components!

#### MECHANICAL SEAL REPLACEMENT

Refer to Figures 1, 1A and 2

**IMPORTANT:** Always use a new casing gasket whenever the unit is disassembled.

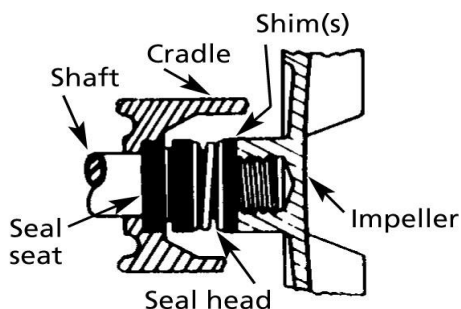

**Figure 1 – Mechanical Seal Replacement**

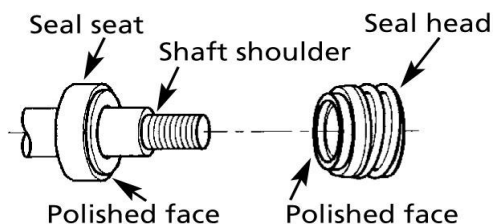

Proper installation is polished face against polished face.

**IMPORTANT:** Be sure that shaft shoulder does not damage either seal face.

**Figure 1A**

#### ▲ CAUTION

The precision lapped faces on the mechanical seal are easily damaged. Handle replacement seal carefully.

1. Remove the casing (Ref. No. 5) and gasket (Ref. No. 11) by removing the fasteners (Ref. No. 23) that attach the casing to the adapter (Ref. No. 19) or bearing housing (Ref. No. 12).
2. Remove the impeller (Ref. No. 6) and shims (Ref. No. 7) by unscrewing it counterclockwise, facing impeller.
3. Carefully remove seal head (Ref. No. 9).

**NOTE:** For Model 2760-99, remove shaft sleeve (Ref. No. 8) also.

4. Remove the seal seat (Ref. No. 10) from the cavity in the adapter or the bearing housing using two screwdrivers or other suitable tools.

**IMPORTANT:** Always replace both the seal seat and the seal head to insure proper mating of components.

5. Thoroughly clean the shaft surface and all surfaces of the seal seat cavity in the adapter or bearing housing.
6. Coat the inside of the seal cavity and the outside of the rubber cup gasket on the seal seat with soapy water.

#### ▲ CAUTION

The polished portion of seal seat should be kept clean. HANDLE CAREFULLY!

7. Push the seal seat into cavity, seating it firmly and squarely with FINGER PRESSURE ONLY. DO NOT use a screwdriver or any other tool that could mark the precision lapped face.
8. Coat inside of the shaft sleeve with clean cup grease or Vaseline. (Model 2760-99 only.) Remove excess grease.

#### ▲ CAUTION

DO NOT touch the polished face of seal head (Ref. No. 9). Seal head should be kept clean.

9. Wet the inside rubber portion of seal head with soapy water.
10. Slide the seal head onto the shaft sleeve or pump shaft (Ref. No. 14) with polished face towards polished seal seat.
11. Replace shims and impeller. (See Shim Adjustment.)
12. Remount gasket and casing.
13. After assembly, turn pump shaft by hand slowly, to check for striking of the impeller on the casing. If rubbing or striking occurs, adjust impeller shims as required (See Shim Adjustment).

# Self-Priming Centrifugal Pedestal Pumps

## High Volume Dewatering Cast Iron and Stainless Steel Models

### BEARING HOUSING SERVICE FOR MODELS

#### 2760-99, 2820-98 AND 2761-99

1. Remove the front pump assembly as described under Mechanical Seal Replacement (Steps 1, 2 & 3).
2. Disassemble the bearing housing (Ref. No. 12) from pump adapter (Ref. No. 19) by removing the four hex head cap screws (Ref. Nos. 20 and 21).
3. Remove the shaft bearing (Ref. No. 22) and shaft (Ref. No. 14) as an assembly by first removing the snap ring (Ref. No. 17). Push the shaft bearing assembly out of the bearing housing by rapping on the threaded end of the shaft with a soft mallet, or block of wood and a hammer.
4. The ball bearings can now be removed from the shaft.
5. If shaft bearings have been removed from shaft, replace by sliding bearing on shaft to shoulder. Replace shaft bearing assembly by sliding assembly into housing threaded end first. Push shaft bearing assembly completely in by gently tapping on keyway end of shaft with a soft mallet. Replace snap ring.
6. Reverse steps 1 thru 3 to reassemble pump.

**IMPORTANT:** After pump is assembled, it is necessary to rotate pump shaft by hand to check for striking of the impeller. If striking or rubbing occurs, adjust impeller shims as required (See Shim Adjustment).

#### BEARING HOUSING SERVICE FOR MODEL 2820-99 & 282P-95

1. Remove the front pump assembly as described under Mechanical Seal Replacement (Steps 1, 2 & 3).
2. Remove the shaft bearing assembly (Ref. No. 14) by first removing the snap ring (Ref. No. 17). Push the shaft bearing assembly out of the bearing housing by rapping on the threaded end of the shaft with a soft mallet, or block of wood and a hammer.
3. Flinger washer (Ref. No. 13) will come loose at this time.
4. Replace shaft bearing assembly by sliding assembly into the housing, threaded end first. Push shaft bearing assembly completely in by gently tapping on keyway end of shaft with a soft mallet. Replace snap ring.
5. Reverse steps 1 thru 3 to reassemble pump.

**IMPORTANT:** After pump is completely assembled it is necessary to rotate pump shaft by hand to check for striking of the impeller. If striking or rubbing occurs, adjust impeller shims as required (See Shim Adjustment).

### SHIM ADJUSTMENT

When installing a replacement impeller (Ref. No. 6), it may be necessary to vary the number of shims (Ref. No. 16) that will be required. This is done by adding one shim more than was removed and reassembling the pump as follows:

**IMPORTANT:** When the clearance between the impeller and casing (Ref. No. 5) exceeds 1/16" at the face of the impeller or 1/8" on the outside diameter of the impeller, it may be necessary to take corrective action.

1. Insure that the casing is snugly in place and check the shaft (Ref. No. 14) to make sure it is turning freely. If it turns freely, check to insure that the adapter (Ref. No. 19) or bearing housing (Ref. No. 12) and casing are firmly seated, compressing gasket (Ref. No. 11) where they meet on the outside. If a gap exists, tighten the fasteners (Ref. No. 1) and recheck the shaft for free turning. Tighten carefully, turning shaft while tightening. If shaft seizes before fasteners are completely tight, disassemble pump and remove one shim and repeat reassembly.
2. If at any time during shim adjustment the shaft does not turn free or the impeller strikes when turning the shaft, repeat Shim Adjustment procedure.

**For Repair Parts contact dealer where pump was purchased.**

Please provide following information:

-Model Number

-Serial Number (if any)

Part description and number as shown in parts list

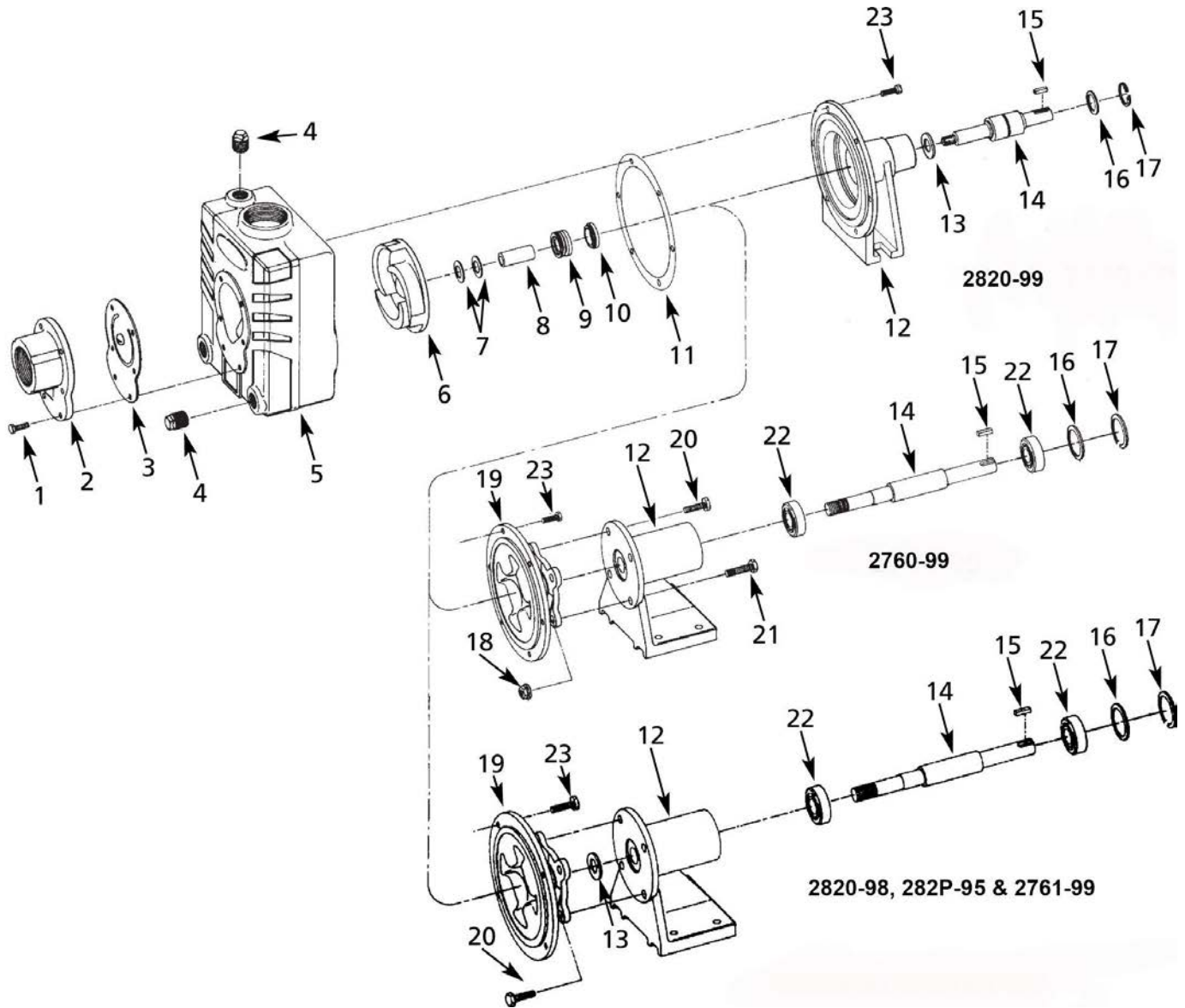

**Figure 2 – Repair Parts Illustration**

# Repair Parts List

| Ref.<br>No. | Description                                    | Part Number for Models: |                    |                    |                    |                    | Qty. |
|-------------|--|-------------------------|--------------------|--------------------|--------------------|--------------------|------|
|             |  | 2820-98                 | 2820-99-DISC       | 282P-95            | 2760-99            | 2761-99            |      |
| 1           | 1/4" - 20 UNC x 3/4" SS Hex Head Cap Screw     | N/A                     | *                  | *                  | N/A                | N/A                | 6    |
|             | 1/4" - 20 UNC x 3/4" SS Hex Head Cap Screw     | *                       | N/A                | N/A                | *                  | N/A                | 4    |
|             | 5/16" - 18 UNC x 7/8" SS Hex Head Cap Screw    | N/A                     | N/A                | N/A                | N/A                | *                  | 4    |
| 2           | Suction Plate                                  | 2820-050-01             | 1501-000-01        | 2820-050-01        | 1487-000-01        | 2760-050-01        | 1    |
| 3           | Flapper Valve Assembly                         | 2820-304-90             | 1674-000-90        | 1674-000-90        | 1683-000-90        | 2760-304-90        | 1    |
| 4           | 1/2" NPT Pipe Plug                             | *                       | *                  | *                  | *                  | *                  | 3    |
| 5           | Casing   | 1497-003-00             | 1497-000-02        | 1497-000-01        | 1484-000-01        | 2760-003-01        | 1    |
| 6           | Impeller                                       | 2823-010-02             | 2820-011-05        | 2820-011-05        | 1493-000-01        | 2823-010-06        | 1    |
| 7           | Impeller Skim Kit                              | 1657-000-90             | 1657-000-90        | 1657-000-90        | 1658-000-90        | 1657-000-90        | 1    |
| 8           | Shaft Sleeve                                   | N/A                     | N/A                | N/A                | 1483-000-00        | N/A                | 1    |
| 9,10        | <input type="checkbox"/> Seal Assembly, Buna-N | 1640-161-90 (opt.)      | 1640-161-90 (std.) | 1640-161-90 (std.) | 1640-162-90 (std.) | 1640-161-90 (opt.) | 1    |
|             | <input type="checkbox"/> Seal Assembly, Viton  | 1640-161-91 (std.)      | 1640-161-91 (opt.) | 1640-161-91 (opt.) | 1640-162-91 (opt.) | 1640-161-91 (std.) | 1    |
| 11          | Gasket   | 1470-011-00             | 1478-000-00        | 1478-000-00        | 1478-000-00        | 1470-011-00        | 1    |
| 12          | Bearing Housing                                | 3890-090-09             | 1500-000-01        | 3890-090-09        | 1695-030-01        | 3890-090-09        | 1    |
| 13          | Slinger Washer (not required)                  | 1534-000-00             | 1534-000-00        | 1534-000-00        | N/A                | 1534-000-00        | 1    |
| 14          | Pump Shaft                                     | 1696-066-00             | 1509-140-90        | 1696-066-00        | 1695-001-00        | 1696-066-00        | 1    |
| 15          | 3/16" x 3/16" x 3/4" Key                       | 1517-000-00             | 1517-000-00        | 1517-000-00        | 1517-000-00        | 1517-000-00        | 1    |
| 16          | Bearing Shim Kit                               | 1696-008-90             | 1696-003-90        | 1696-008-90        | 1696-008-90        | 1696-008-90        | 1    |
| 17          | Snap Ring                                      | 1695-034-00             | 1516-000-00        | 1695-034-00        | 1695-034-00        | 1695-034-00        | 1    |
| 18          | 3/8" - 16 UNC Hex Flange Nut                   | N/A                     | N/A                | N/A                | *                  | N/A                | 4    |
| 19          | Adapter  | 2820-031-01             | N/A                | 1499-000-00        | 1474-000-01        | 2820-031-01        | 1    |
| 20          | 3/8" - 16 UNC x 1-1/4" Hex Head Cap Screw      | N/A                     | N/A                | N/A                | N/A                | N/A                | 2    |
|             | 3/8" - 16 UNC x 3/4" Hex Head Cap Screw        | *                       | N/A                | *                  | N/A                | *                  | 4    |
| 21          | 3/8" - 16 UNC x 1-3/4" Hex Head Cap Screw      | N/A                     | N/A                | N/A                | N/A                | N/A                | 2    |
| 22          | Bearing  | 1695-031-00             | N/A                | 1695-031-00        | 1695-031-00        | 1695-031-00        | 2    |
| 23          | 1/4" - 20 UNC x 3/4" SS Hex Head Cap Screw     | N/A                     | *                  | *                  | N/A                | N/A                | 6    |
|             | 3/8" - 16 UNC x 1" SS Hex Head Cap Screw       | *                       | N/A                | N/A                | *                  | *                  | 4    |

(\*) Standard Hardware Item, Available Locally

(□) Seal assembly available as set only (includes seal head and seat).



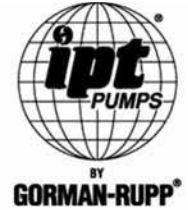

## General Information

**SALES POLICY:** AMT products are sold through our established Distributors. We do not sell direct to the consumer or organization not entitled to trade recognition. Therefore, possession of our catalogs and/or price list(s) does not infer an offer to sell.

**MINIMUM ORDER:** We appreciate your order, however, all orders are subject to a minimum \$35.00 net invoice charge (excluding freight). This applies to all pump and parts purchase orders.

**PRICES:** Prices are subject to change without notice. All orders accepted are subject to prices in effect at time of shipment.

**PAYMENT TERMS:** Terms, upon establishment of credit, are Net 30 days. Past due accounts may be subject to a service charge of 1.5% per month. Domestic or assignable letter of credit is required for all export trade.

**PAST DUE ACCOUNTS:** AMT reserves the right to withhold open account shipments on any past due account. Invoices are considered past due after thirty (30) days. In the interest of sound business, all orders are subject to approval of the Credit Department.

**SHIPPING INSTRUCTIONS:** All shipments will be made F.O.B. the factory. Where instructions for shipment do not appear on the order, the shipment will be made according to our best judgment. Full risk of loss (including transportation delays and losses) shall pass to the customer upon delivery of the products to the carrier at the F.O.B. point. When loss or delay occurs, primary responsibility for tracing rests with the customer. When there is LOSS or APPARENT VISIBLE DAMAGE to a shipment, when tendered for delivery, **DO NOT** give the carrier a clear receipt. Note such damage on the carrier's delivery receipt and **HAVE THE DRIVER SIGN THE RECEIPT.**

**PRODUCT REVISIONS:** AMT reserves the right to discontinue, change or improve its products or any portions thereof without being obligated to provide such a change or improvement for units sold and/or shipped prior to such a change or improvement.

## 12 Month Limited Warranty

### EXTENT AND DURATION OF LIMITED WARRANTY

**Coverage:** AMT Pump Company (herein "AMT") or IPT Pumps by Gorman-Rupp (herein "IPT") or Gorman-Rupp Industries Division of The Gorman-Rupp Company, Patterson, or the Gorman-Rupp Company (herein referred to as "G-R Unit") each individually warrants that its products and parts shall be free from defects in material and workmanship for twelve (12) months from the date of purchase by the original end user when installation is made and maintenance is performed in accordance with G-R Unit's recommendations. Wear and tear resulting from use and items normally consumed in use are not covered.

### EXCEPTIONS

( A ) This Limited Warranty shall not apply to mechanical seals in AMT or IPT pumps and the following products and parts: engines, motors, trade accessories and all other products, components, parts and materials not manufactured by the G-R Units. These items may, however, be covered by the warranties of their respective manufacturers. ( B ) This warranty does not extend to or apply to any unit which has been repaired or altered at any place other than by a G-R Unit, or by persons not expressly approved by a G-R Unit to make repairs or alterations, nor to any unit the serial number, model number or identification of which has been removed, defaced or altered. ( C ) This warranty does not extend to any product manufactured by a G-R Unit, which has been subjected to mis-use, neglect, accident, improper installation, or use in violation of instructions furnished by a G-R Unit. ( D ) Pump Kits: This warranty does not extend to any product sold by a G-R Unit unassembled as a Pump Kit. Pump Kits are warranted against defects in material and workmanship for 60 days from the date of shipment from a G-R Unit. Any Pump Kit parts deemed defective by a G-R Unit will be replaced free of charge within 60 days of shipment. Pump Kits are not returnable for credit.

### LIMITATIONS

**THE G-R UNITS' SOLE AND EXCLUSIVE WARRANTY WITH RESPECT TO THEIR PRODUCTS AND PARTS IS THIS LIMITED WARRANTY. THIS LIMITED WARRANTY IS IN LIEU OF ALL OTHER EXPRESS AND/OR IMPLIED WARRANTIES, INCLUDING IMPLIED WARRANTIES OF MERCHANTABILITY AND FITNESS FOR PARTICULAR PURPOSE.**

### EXCLUSIVE REMEDY AND DAMAGES

The sole and exclusive remedy for breach of this Warranty by a G-R Unit and the entire extent of its liability for such breach or for damages arising from the use of the products and parts covered under this Limited Warranty, shall be as follows:

**LEAD TIME:** Products designated "Quick Ship Product", also referred to as "QSP" will normally be shipped within 24 hours of receipt of a non-cancellable purchase order. Only limited quantities of "QSP" pumps are available.

**STANDARD LEAD TIME:** Lead time is two weeks for all non "QSP" product. AMT reserves the right to revise lead times as required due to availability of materials and all other causes beyond our control.

**VIP SHIPMENT:** Select AMT and IPT branded pumps are available for next day shipment for non-QSP (Quick Ship Products) items and subjected to a specific model surcharge per unit noted in the respective price book. Requires calling for availability, confirmation and a non-cancellable purchase order or credit card payment prior to shipment. The expedited shipping charges are an additional cost added separately from the VIP charges per item. AMT reserves the right to revise lead times as required due to availability of materials and all other causes beyond our control. QSP quantities are limited as determined by AMT.

ALL purchase orders must be submitted via hard copy sent to AMT customer service department by fax, EDI or e-mail.

**RETURN GOODS POLICY:** Goods shall not be returned without a return goods authorization number (RGA) issued by AMT customer service. The RGA number must be listed on the packing list. Only current model and part numbers with a valid date code may be returned (within one year from date of purchase). **A 20% restocking and packaging charge will apply to all returns. All shipping charges must be pre-paid. No exceptions.**

**ORDER CHANGES BY CUSTOMER:** Orders in process may not be changed except with written consent and may be subject to special charges.

- Repair or Replacement:** If inspection shows that any G-R Unit product or part covered under this Limited Warranty is defective in materials or workmanship, the G-R Unit shall repair or replace the defective or non-conforming product or part without charge, whichever the G-R Unit chooses. You must have properly maintained and used the product or part claimed to be defective in accordance with the maintenance schedule or manual, which comes with the product. No allowance will be made for labor, installation, removal, transportation or other charges incurred by you in connection with such repair or replacement.
- To obtain the above remedy:
  - Immediately notify the G-R Unit upon discovery of the claimed defect in materials or workmanship and provide the serial number or date code of the product and/or part(s) or provide the G-R Unit with the invoice or bill of sale referencing the product by no later than the expiration date of the warranty period.
  - The G-R Unit will advise whether inspection will be necessary and how whether repair or replacement will be made. If inspection by the G-R Unit is necessary, the pump or defective part must be sent freight pre-paid to the G-R Unit. Return shipment will be F.O.B. the G-R Unit's plant.
  - Return Goods Authorization Requirement:** No product will be accepted for return or replacement without the prior written authorization of the G-R Unit. Upon such authorization, and in accordance with instructions from the G-R Unit, the product will be returned to the G-R Unit, shipping charges prepaid by the Buyer.
- Damages:** The G-R Unit's liability for damages for breach of this Limited Warranty shall not exceed the amount of the purchase price of the product or part(s) in respect to which Such damages are claimed. **IN NO EVENT SHALL THE G-R UNITS BE LIABLE FOR INCIDENTAL, CONSEQUENTIAL OR SPECIAL DAMAGES FOR BREACH OF THIS LIMITED WARRANTY.**

Some states do not allow the exclusion or limitation of incidental or consequential damages, so the above limitation or exclusion may not apply to you. This Limited Warranty gives you specific legal rights, and you may also have other rights, which vary from state to state.



**A Gorman-Rupp Company**



**BY**

**GORMAN-RUPP®**

[www.amtpump.com](http://www.amtpump.com)