

Type "B" Single Stage
Centrifugal Pump
Electric Motor Drive

Section	CC
Page	50.1
Date	July 1, 2011
Supersedes 1/1/04	

CAST IRON IMPELLER

B1-1/2ZPH

Threaded Case (NPT)

Packing Construction

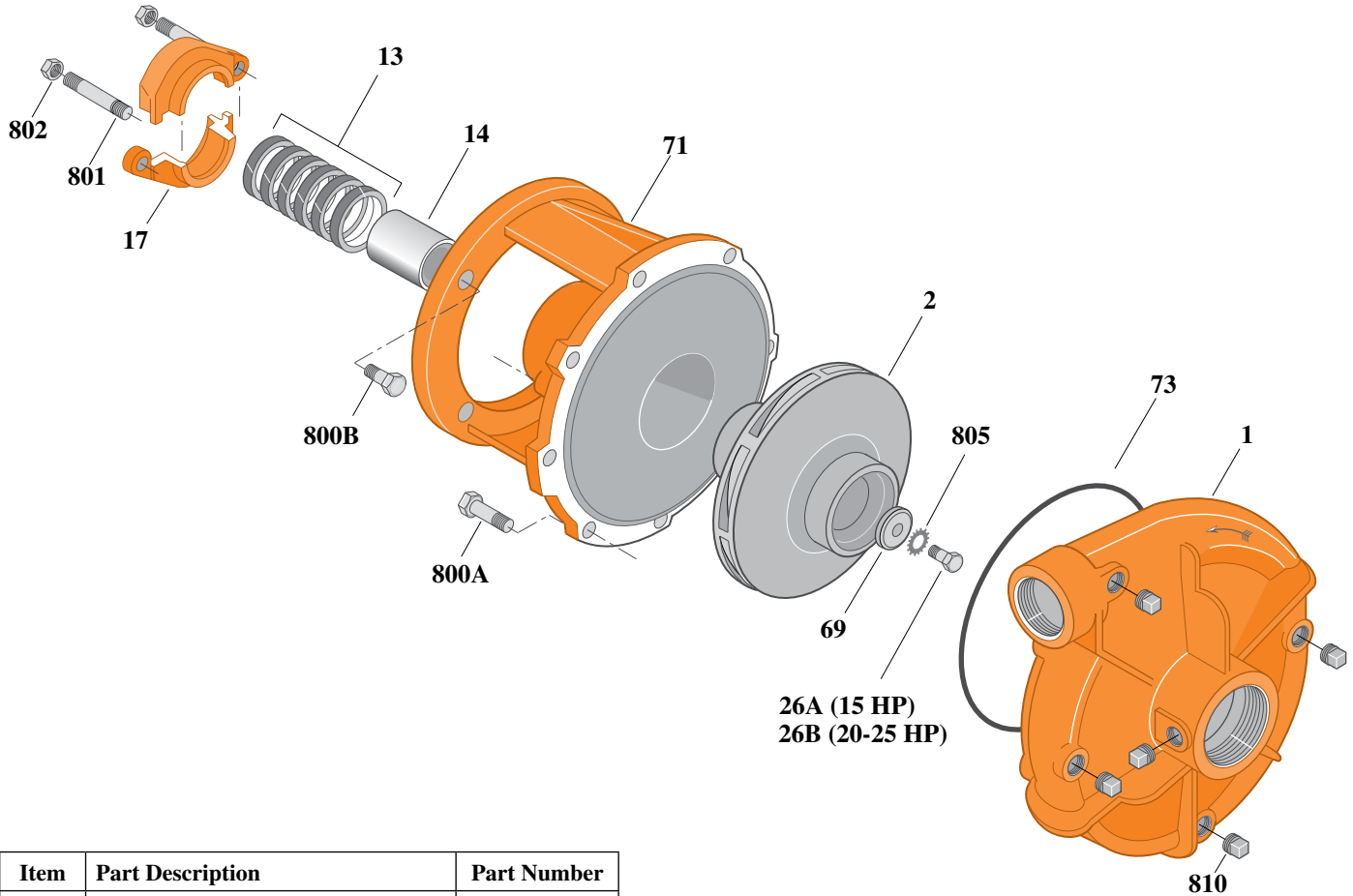

Item	Part Description	Part Number
1	Case, Volute	L03075
2	Impeller	See Table I
13	Rings, Packing (Set of 6)	S13470
14	Sleeve, Shaft	S05149L
17	Gland, Packing	B82470
26A	Screw, Impeller 1/2 - 13 x 1-1/2"	S23623
26B	Screw, Impeller 1/2 - 13 x 1-1/4"	S23621
32	Key, 1/4 x 2-1/4" (See Note 1)	S23677
69	Washer, Impeller	S06319
71	Bracket	See Table II
73	O-Ring (See Note 2)	M14943
800A	Capscrew, 3/8 - 16 x 1-1/8" (8 Req.)	S26827
800B	Capscrew, 1/2 - 13 x 1-1/2" (4 Req.)	S26916
801	Stud, 3/8 - 16 x 4" (2 Req.)	S08303
802	Nut, Hex 3/8 - 16 (2 Req.)	S23343
805	Washer, Lock	S23038
810	Plug, Pipe 1/4 NPT (5 Req.)	S23715

26A (15 HP)
26B (20-25 HP)

Table I

B/M No.	HP	PH	RPM	"U" Dim.	Imp. Dia.	Imp. No.
B53759	15	3	3600	1-1/4"	7.94"	M07666
B52296	20	3	3600	1-1/4"	8.62"	M07665
B52297	25	3	3600	1-1/4"	9.00"	M04906

Table II

HP	PH	Bracket No.	"AK" Fit	"U" Dim.	Motor Frame
15	3	L03827	8-1/2"	1-1/4"	215JP
20	3	L03827	8-1/2"	1-1/4"	254JP
25	3	L03827	8-1/2"	1-1/4"	256JP

NOTE 1: For an explanation of the tabulated material found on this page and for impeller key location, refer to *Supplement A* located at the beginning of this section.

NOTE 2: Also accepts gasket S05126 as replacement for o-ring. See *Supplement E* located at the beginning of this section.