



Type "B" Single Stage Centrifugal Pump Electric Motor Drive

Section	CC
Page	90.3
Date	July 1, 2011
Supersedes 1/1/04	

CAST IRON IMPELLER

B2ZPHS

Flanged Case

Mechanical Shaft Seal Construction

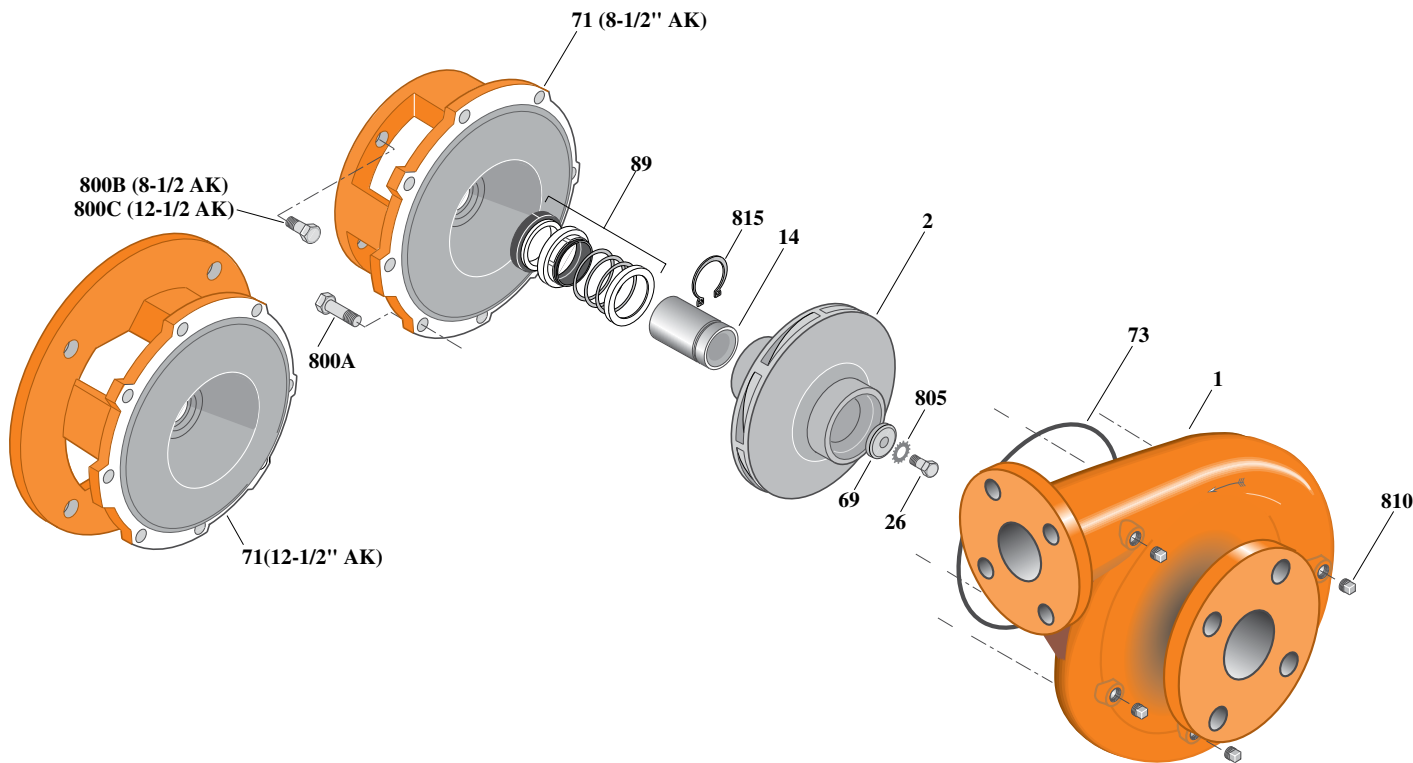

Item	Part Description	Part Number
1	Case, Volute	H05543
2	Impeller	See Table I
14	Sleeve, Shaft	S18869L
26	Screw, Impeller 1/2 - 13 x 1"	S23619
32	Key, 1/4 x 2-1/4" (See Note 1)	S23677
69	Washer, Impeller	S06319
71	Bracket	See Table II
73	O-Ring (See Note 2)	M14943
89	Seal, Mechanical Shaft	S32015
800A	Capscrew, 3/8 - 16 x 1" (8 Req.)	S26826
800B	Capscrew, 1/2 - 13 x 1" (4 Req.) (For 8-1/2 AK)	S26912
800B	Capscrew, 5/8 - 11 x 1-1/4" (4 Req.) (For 12-1/2 AK)	S26997
805	Washer, Lock	S23038
810	Plug, Pipe 1/4 NPT (5 Req.)	S23715
815	Ring, Retaining	S16767

Table I

B/M No.	HP	PH	RPM	"U" Dim.	Imp. Dia.	Imp. No.
B76253	25	3	3600	1-1/4"	8.62"	M07667
B76304	30	3	3600	1-1/4"	9.00"	M07306

Table II

HP	PH	Bracket No.	"AK" Fit	"U" Dim.	Motor Frame
25	3	L04615	8-1/2"	1-1/4"	256JM
30	3	L04627	12-1/2"	1-1/4"	284JM

NOTE 1: For an explanation of the tabulated material found on this page and for impeller key location, refer to *Supplement A* located at the beginning of this section.

NOTE 2: Also accepts gasket S05126 as replacement for o-ring. See *Supplement E* located at the beginning of this section.