

BALDOR® • *RELIANCE*

Product Information Packet

CESSWDM3558T-5

2HP, 1755RPM, 3PH, 60HZ, 145TC, 3536M, TEFC, F1

Part Detail							
Revision:	L	Status:	PRD/A	Change #:		Proprietary:	No
Type:	AC	Prod. Type:	3536M	Elec. Spec:	35WGM812	CD Diagram:	CD0006
Enclosure:	TEFC	Mfg Plant:		Mech. Spec:	35VV818	Layout:	35LYVV818
Frame:	145TC	Mounting:	F1	Poles:	04	Created Date:	06-22-2010
Base:	RG	Rotation:	R	Insulation:	F	Eff. Date:	03-28-2016
Leads:	3#18					Replaced By:	
Literature:		Elec. Diagram:					

Nameplate NP1951A05												
CAT.NO.	CESSWDM3558T-5											
SPEC.	35VV818M812G1											
HP	2											
VOLTS	575											
AMP	2.2											
RPM	1755											
FRAME	145TC					HZ	60			PH	3	
SER.F.	1.15				CODE	M		DES	B		CLASS	F
NEMA-NOM-EFF	88.5					PF	76					
RATING	40C AMB-CONT											
CC	010A					USABLE AT 208V						
DE	6205					ODE	6203					
ENCL	TEFC			SN								

Parts List		
Part Number	Description	Quantity
SA199207	SA 35VV818M812G1	1.000 EA
RA186545	RA 35VV818M812G1	1.000 EA
35FN3002A05	EXFN, PLASTIC, 6.376 OD, .638 ID	1.000 EA
NS2512A01	INSULATOR, CONDUIT BOX X	1.000 EA
35CB5001A17	KOBX KIT, (ALL STAINLESS) W/ .75 NPT	1.000 EA
HA5027A02	HA4054 T-DRAIN X2 BAGGED WITH LABEL	1.000 EA
11XW1032G06	10-32 X .38, TAPTITE II, HEX WSHR SLTD U	1.000 EA
HW3001B01	BRASS CUP WASHER, FOR #8 SCREW	1.000 EA
35FE1913A02	FR ENDPLATE ASSY	1.000 EA
HW4606A01	JM CLIPPER/SEAL (WDE-0667-1064-BH49)	1.000 EA
HW5100A03SP	WAVY WASHER (W1543-017)	1.000 EA
35PE1914A02	PU EP ASSY. FOR LOCKED BRG	1.000 EA
HW4606A02	JM CLIPPER/SEAL (LWE-0938-1624-AL23)	1.000 EA
12XN1032S22	10-32 X 1 3/8 SLOT HEX, STAINLESS STEEL	2.000 EA
HA1049A01	DUBO LOK WASHER SIZE 10 (NYLON LOCK SEAL	2.000 EA
HA1049A01	DUBO LOK WASHER SIZE 10 (NYLON LOCK SEAL	4.000 EA
51XB1214A16	12-14X1.00 HXWSSLD SERTYB	1.000 EA
35FH4005A39	IEC FH NO GREASER (#304 SS)CLEAN ONLY	1.000 EA
10XN1032S06	HEX HD CAP SCREW, SS	3.000 EA
HW2502D13	SS KEY, 3/16 SQ X 1.375	1.000 EA
HA7000A01	KEY RETAINER 7/8" DIA SHAFT	1.000 EA
MJ5001A02	732 CL SEALANT 3 OZ DIXIE BEARING 289100	0.001 EA
HW3001B01	BRASS CUP WASHER, FOR #8 SCREW	1.000 EA
MJ1000A02	GREASE, POLYREX EM EXXON (USe 4824-15A)	0.050 LB

Parts List (continued)		
Part Number	Description	Quantity
51XB1214A16	12-14X1.00 HXWSSLD SERTYB	1.000 EA
HA3100S04	THRUBOLT- 10-32 X 11.250 302 OR 303 SS	4.000 EA
36PA1000	PKG GRP, PRINT PK1016A06	1.000 EA
MN416A01	TAG-INSTAL-MAINT no wire (1200/bx) 11/14	1.000 EA

AC Induction Motor Performance Data

Record # 31563 - Typical performance - not guaranteed values

Winding: 35WGM812-R001	Type: 3536M	Enclosure: TEFC
-------------------------------	--------------------	------------------------

Nameplate Data				575 V, 60 Hz: Single Voltage Motor	
Rated Output (HP)	2			Full Load Torque	5.91 LB-FT
Volts	575			Start Configuration	direct on line
Full Load Amps	2.2			Breakdown Torque	26.1 LB-FT
R.P.M.	1755			Pull-up Torque	13.4 LB-FT
Hz	60	Phase	3	Locked-rotor Torque	18.6 LB-FT
NEMA Design Code	B	KVA Code	M	Starting Current	20.4 A
Service Factor (S.F.)	1.15			No-load Current	1.25 A
NEMA Nom. Eff.	88.5	Power Factor	76	Line-line Res. @ 25°C	10.7 Ω
Rating - Duty	40C AMB-CONT			Temp. Rise @ Rated Load	46°C
S.F. Amps				Temp. Rise @ S.F. Load	55°C
				Locked-rotor Power Factor	46
				Rotor inertia	0.213 LB-FT ²

Load Characteristics 575 V, 60 Hz, 2 HP

% of Rated Load	25	50	75	100	125	150	S.F.
Power Factor	34	56	68	76	81	84	79
Efficiency	79.8	87	88.1	88.5	87.8	86.5	88
Speed	1789	1780	1770	1759	1747	1733	1752
Line amperes	1.33	1.55	1.86	2.21	2.63	3.1	2.46

Performance Graph at 575V, 60Hz, 2.0HP Typical performance - Not guaranteed values

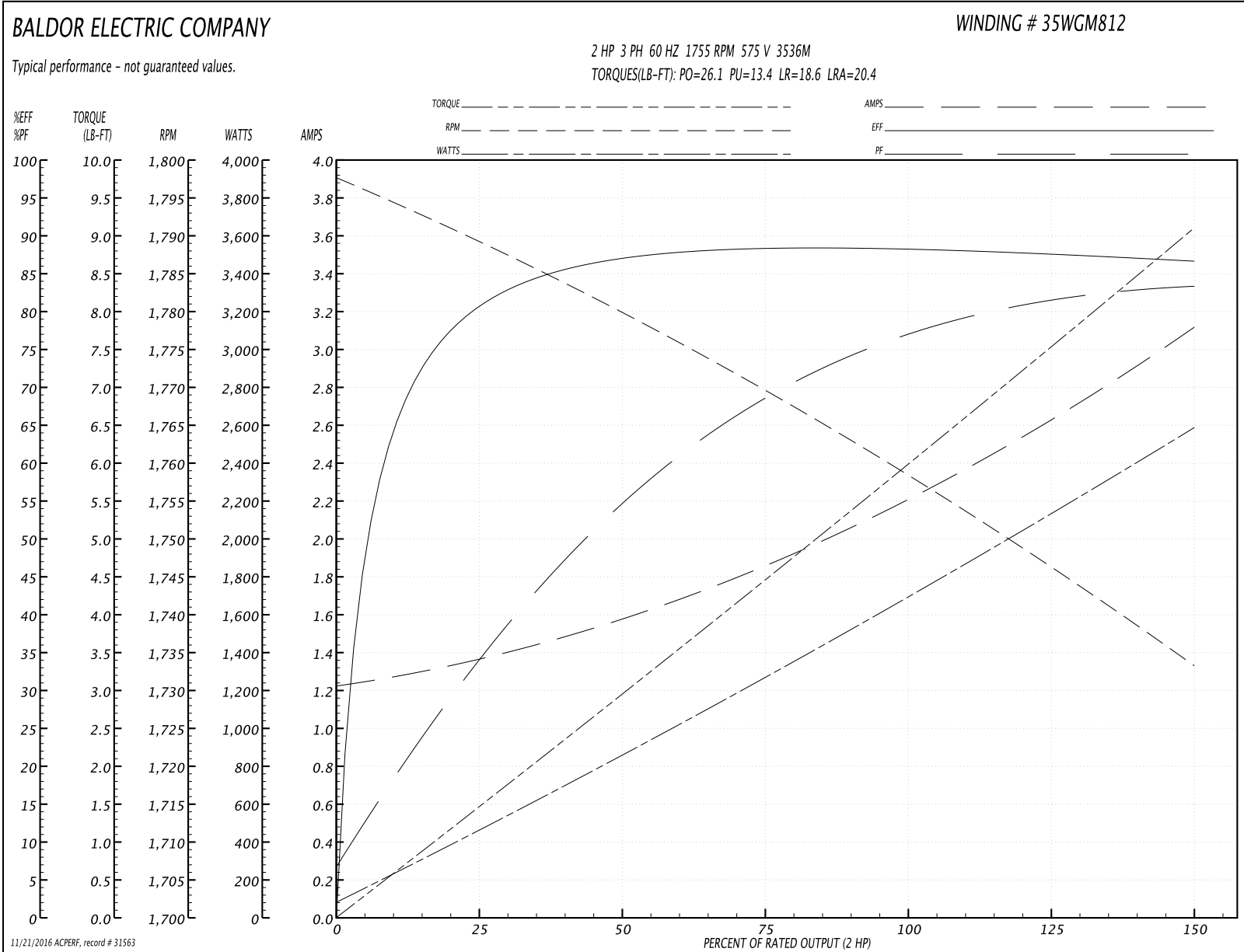

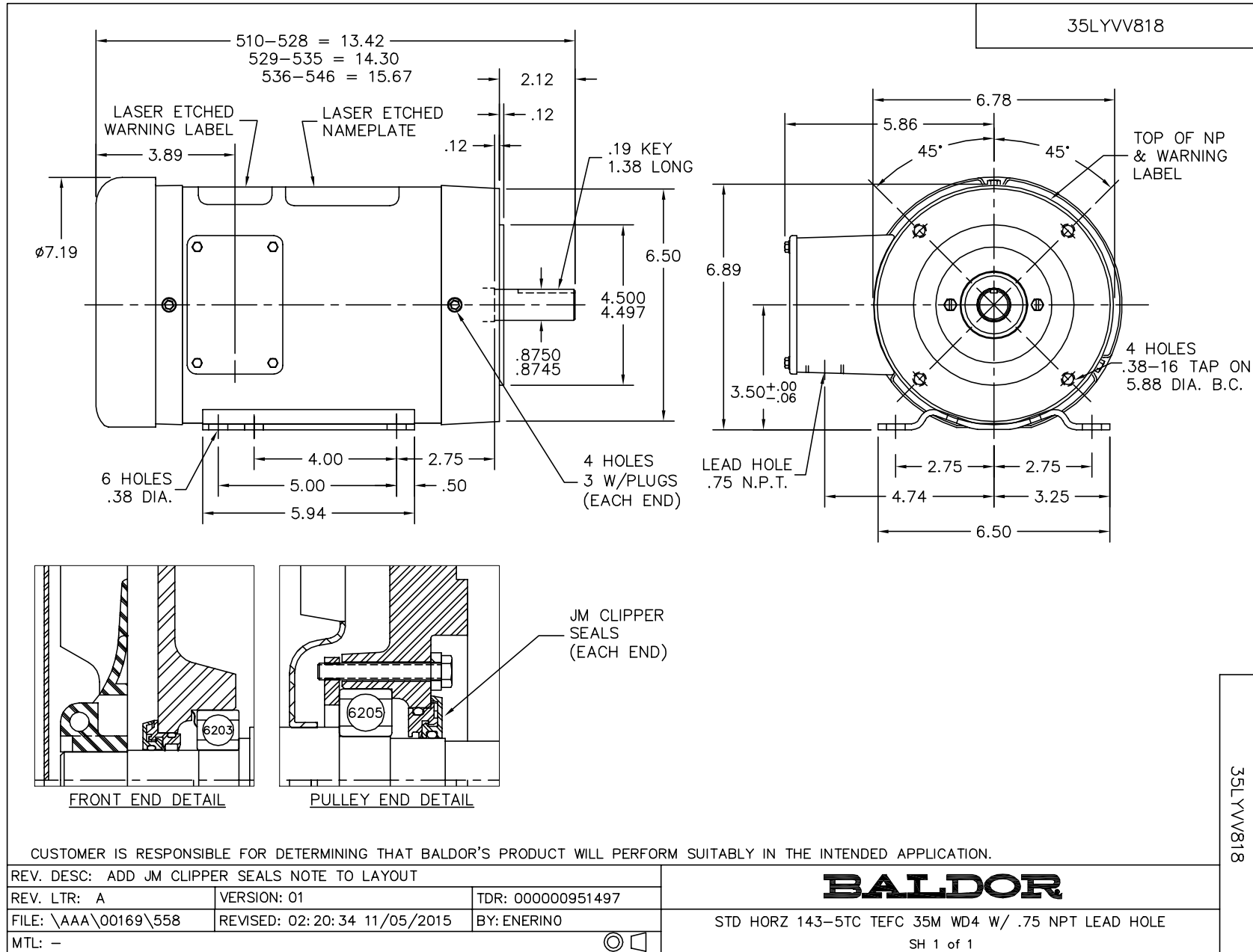

CD0006



NOTES:

1. THREE LEAD MOTOR MAY BE EITHER WYE CONNECTED OR DELTA CONNECTED.
2. INTERCHANGE ANY TWO LINE LEADS TO REVERSE ROTATION.
3. OPTIONAL THERMOSTATS ARE PROVIDED WHEN SPECIFIED.
4. ACTUAL NUMBER OF INTERNAL PARALLEL CIRCUITS MAY VARY.
5. LEAD COLORS ARE OPTIONAL. LEADS MUST BE NUMBERED AS SHOWN.

REV. DESC: REVISE TO SHOW OPTIONAL COLORS			
REV. LTR: D	BY: JLP	REVISED: 01/21/99 4:02	TDR: 0171435
9000D		FILE: AAA00005141	MDL: -
		MTL: -	

BALDOR ELECTRIC Co.

3PH, SV, 3 LEADS, WYE OR DELTA CONNECTED

CD0006