

# **BALDOR**® • *RELIANCE*

## Product Information Packet

# **CEWDM3559T-5**

**3HP,3450RPM,3PH,60HZ,145TC,3532M,TEFC,F1**

Part Detail							
Revision:	D	Status:	PRD/A	Change #:		Proprietary:	No
Type:	AC	Prod. Type:	3532M	Elec. Spec:	35WGM839	CD Diagram:	CD0006
Enclosure:	TEFC	Mfg Plant:		Mech. Spec:	35TT936	Layout:	35LYTT936
Frame:	145TC	Mounting:	F1	Poles:	02	Created Date:	05-16-2013
Base:	RG	Rotation:	R	Insulation:	F	Eff. Date:	02-23-2016
Leads:	3#18					Replaced By:	
Literature:		Elec. Diagram:					

Nameplate NP1669L										
CAT.NO.	CEWDM3559T-5									
SPEC.	35TT936M839G1									
HP	3									
VOLTS	575									
AMP	2.9									
RPM	3450									
FRAME	145TC				HZ	60			PH	3
SER.F.	1.15		CODE	L	DES	B		CLASS	F	
NEMA-NOM-EFF	86.5		PF	92						
RATING	40C AMB-CONT									
CC	010A				USABLE AT 208V					
DE	6205			ODE	6203					
ENCL	TEFC		SN							
BLANK										

Parts List		
Part Number	Description	Quantity
SA263194	SA 35TT936M839G1	1.000 EA
RA249917	RA 35TT936M839G1	1.000 EA
34FN3002B01	EXTERNAL FAN, PLASTIC, .637/.639 HUB W/	1.000 EA
NS2512A01	INSULATOR, CONDUIT BOX X	1.000 EA
35CB3010A01W	35 CB .75 NPT @ 6:00, WHITE EPOXY	1.000 EA
35GS1040	35 MOLDED GASKET W/LIP, LEAD SEAL,	1.000 EA
51XB1016A07	10-16 X 7/16 HXWSSLD SERTYB	2.000 EA
11XW1032G06	10-32 X .38, TAPTITE II, HEX WSHR SLTD U	1.000 EA
35EP3100M04MW	FREP TEFC,"O" DRILLS,NO GRSSR, MACH.WHITE	1.000 EA
HW4032A01	BLACK DRAIN PLUG FOR WASH DOWN MOTORS	3.000 EA
HW5100A03SP	WAVY WASHER (W1543-017)	1.000 EA
35EP3300A48MW	SPL FACE MTD EP - 205 BRG - W/SEAL FOR W	1.000 EA
HW4032A01	BLACK DRAIN PLUG FOR WASH DOWN MOTORS	3.000 EA
HW4600B49	SEAL 0.938 X 1.624 X 0.250 SINGLE LIP DB	1.000 EA
12XN1032S20	10-32 X 1-1/4 HEX M.S. , STAINLESS STEEL	2.000 EA
35FH4005A32SP	IEC FH NO GRSSR W/3 HOLES - PRIMED	1.000 EA
11XW1032S06	10-32 X .38, TAPTITE II, HEX WSHR SLTD U	3.000 EA
35CB4522	35 LIPPED CB LID PRIMED	1.000 EA
35GS1030A02	35 GS FOR CB LID - WHITE NEOPRENE	1.000 EA
59XW0832S07	TAPTITE II,HEX WSHR UNSLTD SER,410 S.S.,	4.000 EA
HW1003S08	WASHER, #8 EX TH LK, SS	4.000 EA
HW4600B39SP	V-RING SLINGER 0.550 X 0.790 X .18 VITON	1.000 EA
HW4600B46	V-RING SLINGER 0.875 X 1.420 X .24 VITON	1.000 EA
HW2502D13	SS KEY, 3/16 SQ X 1.375	1.000 EA

<b>Parts List (continued)</b>		
<b>Part Number</b>	<b>Description</b>	<b>Quantity</b>
HA7000A01	KEY RETAINER 7/8" DIA SHAFT	1.000 EA
LB1164	LABEL,WARNING AND DRAIN	1.000 EA
10XF0440S02	04-40 X 1/8 TYPE F HEX HD STAINLESS STIC	2.000 EA
HA5027A01	HA4066A01 T-DRAIN X2 BAGGED	1.000 EA
S/P107-000-001	SUPER E PROC'S-FS, WS & CK PLTS	1.000 EA
MJ1000A02	GREASE, POLYREX EM EXXON (USe 4824-15A)	0.050 LB
MJ5001A27	32220KN GRAY SEALER *MIN BUY 4 QTS=1GAL	0.001 QT
MG1025W01	WILKOFAS, 781.01, SIGNAL WHITE #9003	0.017 GA
MG1500Y02	PRIMER,347.29+347.29C ACTIVATOR WILKOPON	0.017 GA
HA3100S15	THRUBOLT - 10-32 X 9.375	4.000 EA
MN416A01	TAG-INSTAL-MAINT no wire (1200/bx) 11/14	1.000 EA
LB1119N	WARNING LABEL	1.000 EA
LC0006	CONNECTION LABEL	1.000 EA
NP1669L	SS WD SUPER-E UL CSA-EEV PREM REV MTG	1.000 EA
36PA1000	PKG GRP, PRINT PK1016A06	1.000 EA

**AC Induction Motor Performance Data**

Record # 32143 - Typical performance - not guaranteed values

<b>Winding:</b> 35WGM839-R001	<b>Type:</b> 3532M	<b>Enclosure:</b> TEFC
-------------------------------	--------------------	------------------------

Nameplate Data				575 V, 60 Hz: Single Voltage Motor	
Rated Output (HP)	3			Full Load Torque	4.5 LB-FT
Volts	575			Start Configuration	direct on line
Full Load Amps	2.9			Breakdown Torque	17.8 LB-FT
R.P.M.	3450			Pull-up Torque	10.9 LB-FT
Hz	60	Phase	3	Locked-rotor Torque	15.8 LB-FT
NEMA Design Code	B	KVA Code	L	Starting Current	26.1 A
Service Factor (S.F.)	1.15			No-load Current	0.948 A
NEMA Nom. Eff.	86.5	Power Factor	92	Line-line Res. @ 25°C	7.47 Ω
Rating - Duty	40C AMB-CONT			Temp. Rise @ Rated Load	61°C
S.F. Amps				Temp. Rise @ S.F. Load	74°C
				Locked-rotor Power Factor	47
				Rotor inertia	0.0885 LB-FT <sup>2</sup>

Load Characteristics 575 V, 60 Hz, 3 HP

% of Rated Load	25	50	75	100	125	150	S.F.
Power Factor	58	77	86	88	89	90	89
Efficiency	83.8	87.9	88.1	87.2	85.5	83.4	86.2
Speed	3562	3531	3497	3461	3419	3373	3436
Line amperes	1.19	1.67	2.23	2.88	3.6	4.32	3.31

Performance Graph at 575V, 60Hz, 3.0HP Typical performance - Not guaranteed values

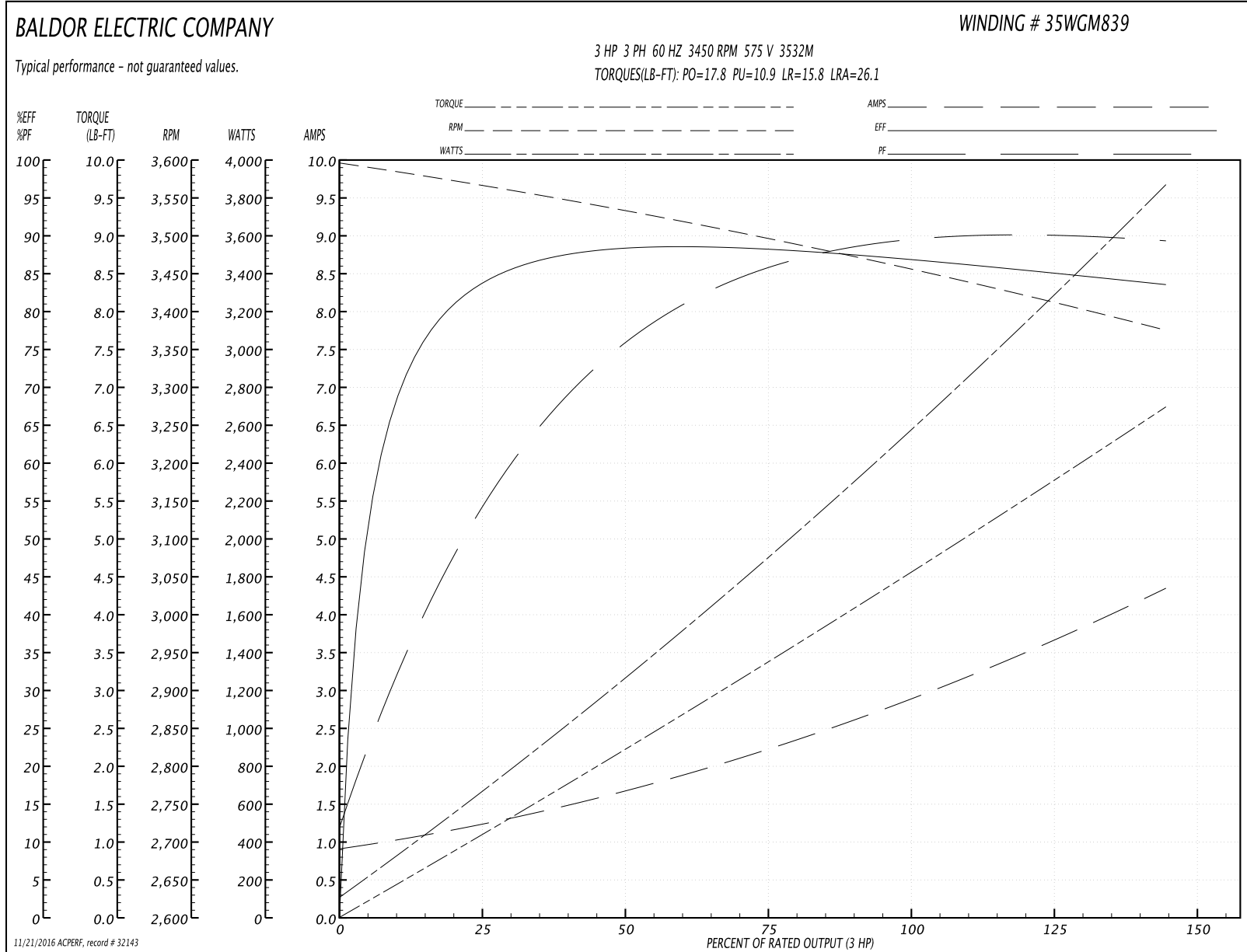

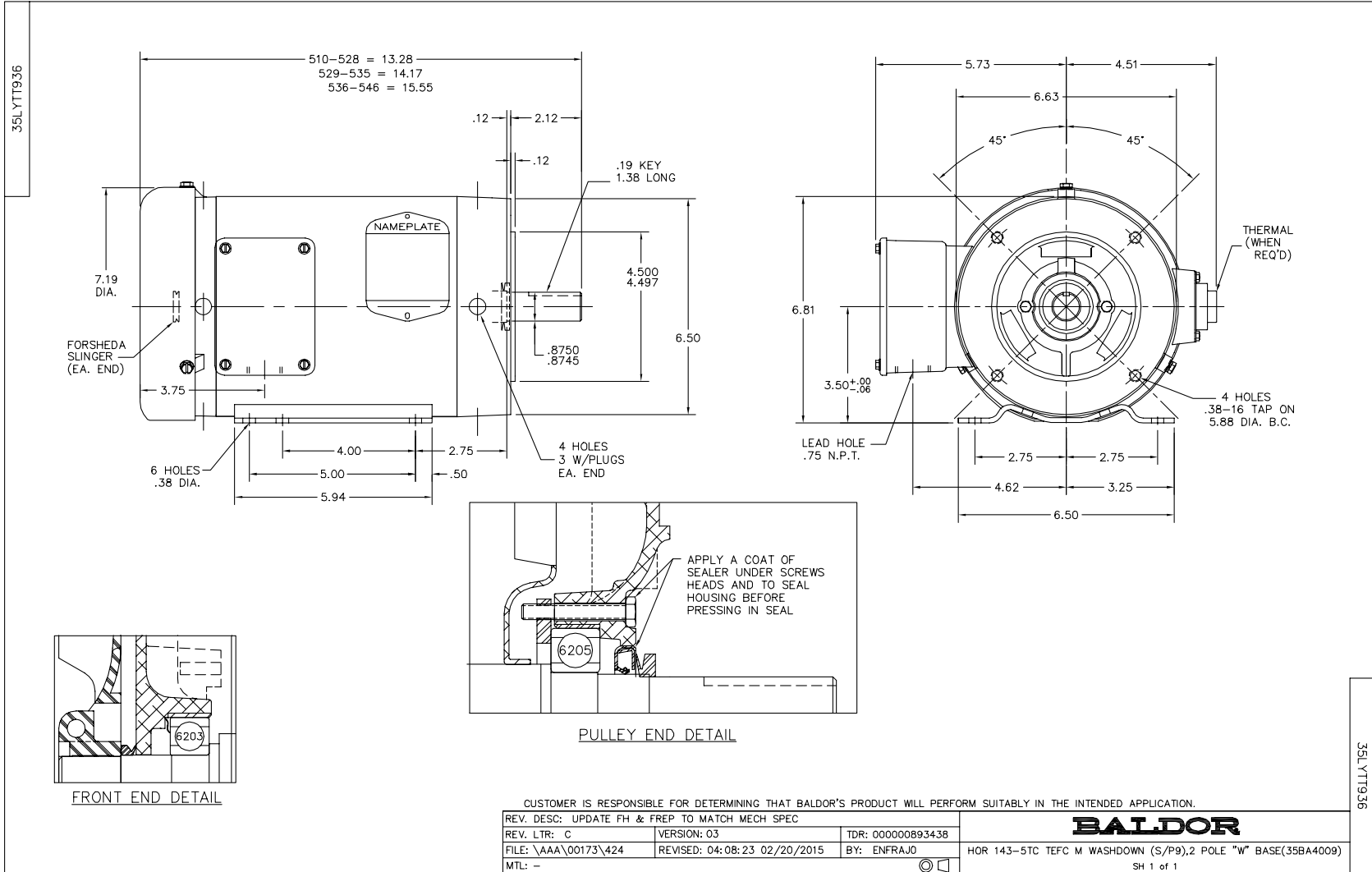

CD0006



NOTES:

1. THREE LEAD MOTOR MAY BE EITHER WYE CONNECTED OR DELTA CONNECTED.
2. INTERCHANGE ANY TWO LINE LEADS TO REVERSE ROTATION.
3. OPTIONAL THERMOSTATS ARE PROVIDED WHEN SPECIFIED.
4. ACTUAL NUMBER OF INTERNAL PARALLEL CIRCUITS MAY VARY.
5. LEAD COLORS ARE OPTIONAL. LEADS MUST BE NUMBERED AS SHOWN.

REV. DESC: REVISE TO SHOW OPTIONAL COLORS			
REV. LTR: D	BY: JLP	REVISED: 01/21/99 4:02	TDR: 0171435
9000D		FILE: AAA00005141	MDL: -
		MTL: -	

**BALDOR ELECTRIC Co.**

3PH, SV, 3 LEADS, WYE OR DELTA CONNECTED

CD0006