

BALDOR® • ***RELIANCE***

Product Information Packet

EM2544T-CI

50HP, 1185RPM, 3PH, 60HZ, 365T, 1466M, OPEN, F1

Part Detail							
Revision:	K	Status:	PRD/A	Change #:		Proprietary:	No
Type:	AC	Prod. Type:	A36052M	Elec. Spec:	A36WG0753	CD Diagram:	416820-002
Enclosure:	DP	Mfg Plant:		Mech. Spec:		Layout:	617428-130
Frame:	365T	Mounting:	F1	Poles:	06	Created Date:	10-19-2010
Base:		Rotation:	R	Insulation:	F	Eff. Date:	11-28-2016
Leads:	3#6,6#8					Replaced By:	
Literature:		Elec. Diagram:					

Nameplate NP2383L										
CAT.NO.	EM2544T-CI			SPEC NO.	P36G3403					
HP	50	AMPS	120/60.3		VOLTS	230/460		DESIGN	B	
FRAME	365T	RPM	1185	HZ	60	AMB	40	SF	1.15	
DRIVE END BEARING	65BC03J30X			PHASE	3	DUTY	CONT		INSUL.CLASS	F
OPP D.E. BEARING	65BC03J30X			TYPE	P	ENCL	DP	CODE	G	
SER.NO.				POWER FACTOR	83		NEMA-NOM-EFFICIENCY	94.1		
NEMA NOM/CSA QUOTED EFF				MAX CORR KVAR	15.0		GUARANTEED EFFICIENCY	93.6		
				MOTOR WEIGHT	722					

Parts List		
Part Number	Description	Quantity
SA209370	SA P36G3403	1.000 EA
RA196632	RA P36G3403	1.000 EA
000613006PU	N/P (RELEASE QTY 10,000) UL CSA LABLE	1.000 EA
000692000VD	LABEL WARNING	1.000 EA
NP2383L	SUPER-E ,SS, CC, CSA-C US, CSA EEV	1.000 EA
421948032	LABEL, MYLAR	1.000 EA
004824015A	GREASE POLYREX EM	0.544 LB
032018024CK	HHCS 3/8-16X3 PLTD.	3.000 EA
032018028DK	HHCS 1/2-13X3-1/2 PLTD.	4.000 EA
032376004JB	RHMS 10-32X1/2PLTD-360	3.000 EA
034001009AB	WSHR #10 PLATED-360	3.000 EA
034017009AB	LCKW NO.10 PLATED-360	3.000 EA
035000001A	ALFTG 1/8" 1610-BL	1.000 EA
035000001A	ALFTG 1/8" 1610-BL	1.000 EA
034690002AB	"unbulked" PPLG 1/4" PLTD.	1.000 EA
078556001A	BAFFL 360 SUB PAINT	1.000 EA
085920052A	BRKT 360 085920051WCC KB	1.000 EA
410700004F	WSHR	1.000 EA
032018024CK	HHCS 3/8-16X3 PLTD.	3.000 EA
032018028DK	HHCS 1/2-13X3-1/2 PLTD.	4.000 EA
032376004JB	RHMS 10-32X1/2PLTD-360	3.000 EA
034001009AB	WSHR #10 PLATED-360	3.000 EA
034017009AB	LCKW NO.10 PLATED-360	3.000 EA
034690002AB	"unbulked" PPLG 1/4" PLTD.	1.000 EA

Parts List (continued)		
Part Number	Description	Quantity
078556001A	BAFFL 360 SUB PAINT	1.000 EA
085920052A	BRKT 360 085920051WCC KB	1.000 EA
032018005AK	HHCS 1/4-20X5/8 PLATED	4.000 EA
032018008CK	HHCS 3/8-16X1L PLATED	2.000 EA
033512004LB	HHTTS 1/4-20X1/2 PLTD.	1.000 EA
048897010DG	PLUG,ODE BRKT - 360	1.000 EA
077176000L	C/BOX, PAINTED 360-400	1.000 EA
077176001A	CBOXC, PAINTED 360-400	1.000 EA
415000103D	T/LUG #4AWG-1/0AWG W/HOLE FOR .250 BOLT	1.000 EA
MG1000Y03	MUNSELL 2.53Y 6.70/ 4.60, GLOSS 20,	0.250 GA
033775004EA	DRSCR #6-1/4 304 S.S.	2.000 EA
034180034HA	KEY 5/8X5/8X4-1/4 L	1.000 EA
14PA1000	PACKAGING 314 GROUP COMBINED PRINT	1.000 EA
043292000AJ	GASK 320-400	1.000 EA
402731001A	GASK 360-440	1.000 EA

REL. S.O.	FRAME	HP	TYPE	PHASE/HERTZ	RPM	VOLTS
	365T	50	P	3/60	1185	230/460
AMPS	DUTY	AMB °C/ INSUL.	S.F.	NEMA DESIGN	CODE LETTER	ENCL.
120/60.3	CONT	40/F	1.15	B	G	PROT
E/S	ROTOR	TEST S.O.	TEST DATE	STATOR RES. @25 °C (BETWEEN LINES)		
892140	418141-70-NE	---	---	.0393/.157		

PERFORMANCE

LOAD	HP	AMPERES	RPM	POWER FACTOR %	EFFICIENCY %
NO LOAD	0	24.8	1200	3.81	0
1/4	12.5	28.4	1196	45.1	91.7
2/4	25.0	36.6	1193	67.9	94.3
3/4	37.5	47.5	1189	78.2	94.5
4/4	50.0	60.1	1185	82.8	94.1
5/4	62.5	74.0	1180	84.7	93.3

SPEED TORQUE

	RPM	TORQUE % FULL LOAD	TORQUE LB.-FT.	AMPERES
LOCKED ROTOR	0	149	330	353
PULL UP	350	122	271	322
BREAKDOWN	1118	246	546	209
FULL LOAD	1185	100	222	60.1

AMPERES SHOWN FOR 460. VOLT CONNECTION. IF OTHER VOLTAGE CONNECTIONS ARE AVAILABLE, THE AMPERES WILL VARY INVERSELY WITH THE RATED VOLTAGE

REMARKS: TYPICAL DATA
XE MOTOR-TYPICAL DATA-NEMA NOM. EFF. 93.6 PCT

BALDOR	DR. BY	W. L. SMITH	A-C MOTOR
	CK. BY	J. J. HARRISON	
	APP. BY	W. L. SMITH	PERFORMANCE DATA
	DATE	03/03/06	ISSUE DATE 12/15/10

REL. S.O. _____ RPM 1185 S.F. 1.15 ROTOR 418141-70-NE
 FRAME 365T VOLTS 230/460 NEMA DESIGN B TEST S.O. TYPICAL DATA
 HP 50 AMPS 120/60.3 CODE LETTER G TEST DATE ---
 TYPE P DUTY CONT ENCLOSURE PROT STATOR RES. @ 25 °C .0393/.157
 PHASE/HERTZ 3/60 AMB °C/INSUL 40/F E/S 892140 OHMS (BETWEEN LINES)

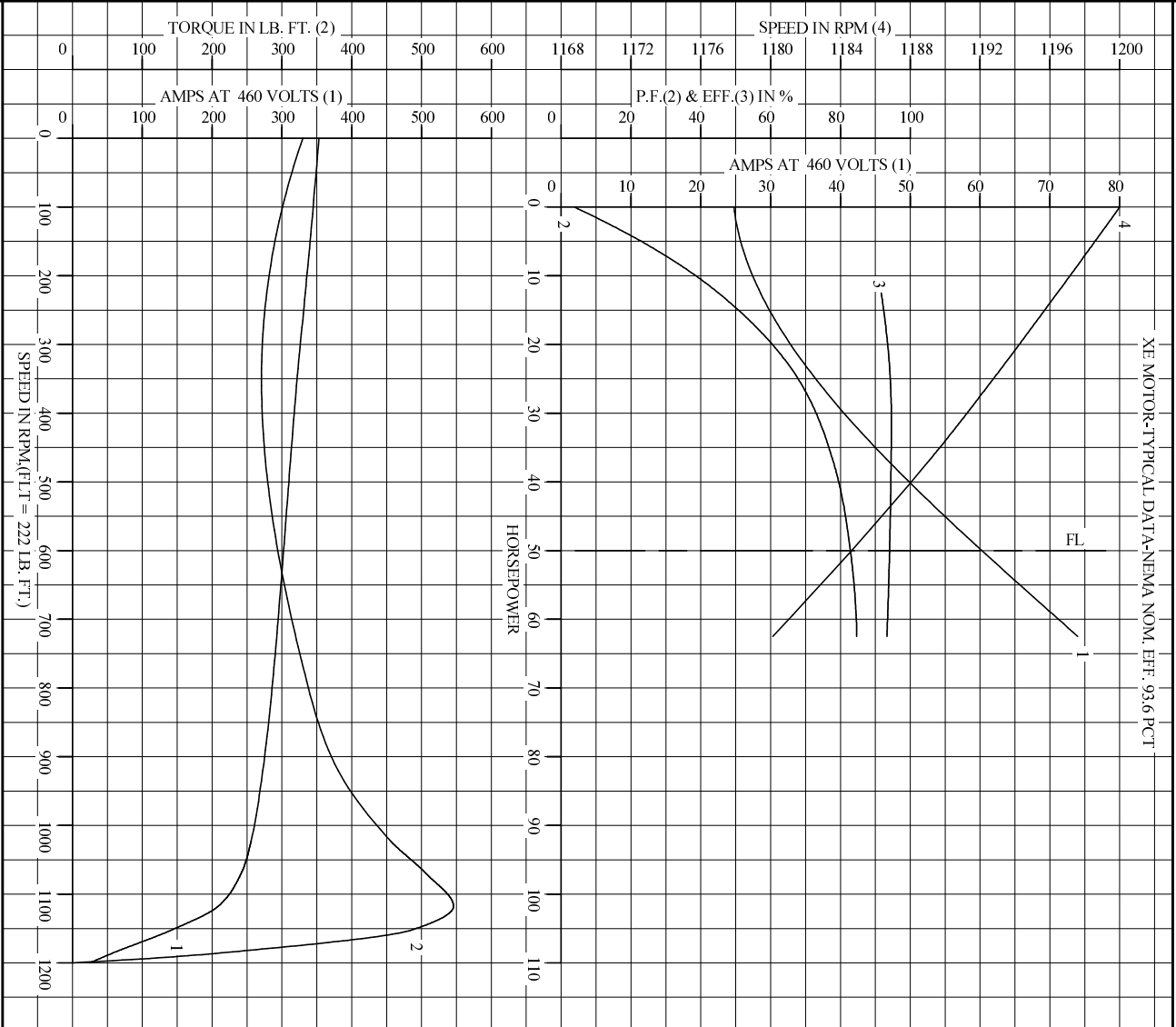

AMPERES SHOWN FOR 460 VOLT CONNECTION, IF OTHER VOLTAGE CONNECTIONS ARE AVAILABLE, THE AMPERES WILL VARY INVERSELY WITH THE RATED VOLTAGE.



DR. BY W.L. SMITH
 CK. BY J.H. HARRISON
 APP. BY W.L. SMITH
 DATE 03/03/06

A-C MOTOR
PERFORMANCE
CURVES
 A36WG0753-R001
 ISSUE DATE 12/15/10

Printed on 12/15/10 9:24 @ pscs-motoreng

REL. S.O. RPM 1185 S.F. 1.15 ROTOR 418141-70-NE
 FRAME 365T VOLTS 230/460 NEMA DESIGN B TEST S.O. TYPICAL DATA
 HP 50 AMPS 120/60.3 CODE LETTER G TEST DATE ---
 TYPE P DUTY CONT ENCLOSURE PROT STATOR RES. @ 25 °C. 0393/.157
 PHASE/HERTZ 3/60 AMB °C/INSUL 40/F E/S 892140 OHMS (BETWEEN LINES)

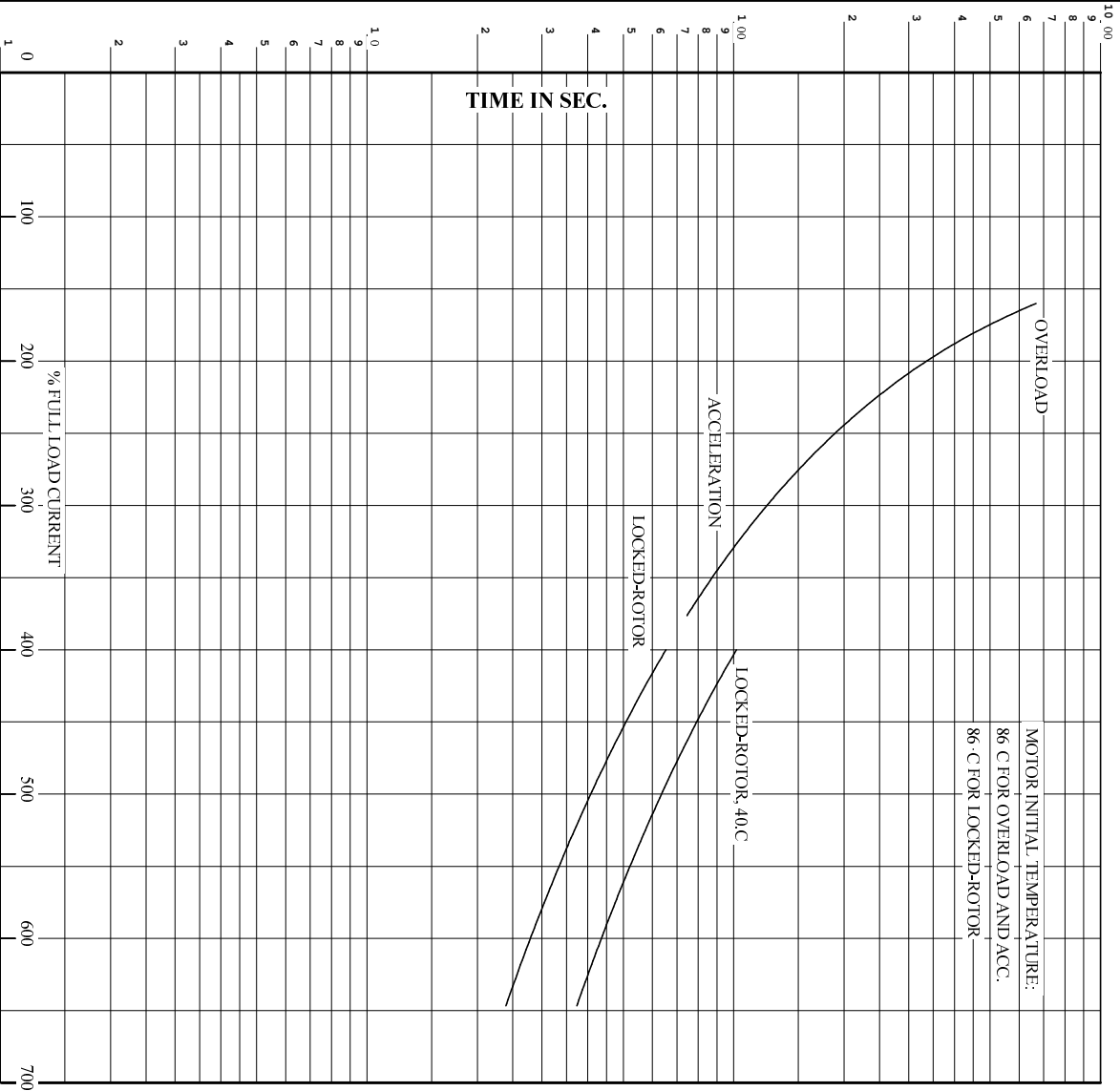

REMARKS: THERMAL LIMIT CURVE
 XE MOTOR-TYPICAL DATA-NEMA NOM. EFF. 93.6 PCT

AMPERES SHOWN FOR 460 VOLT CONNECTION, IF OTHER VOLTAGE CONNECTIONS ARE AVAILABLE, THE AMPERES WILL VARY INVERSELY WITH THE RATED VOLTAGE.



DR. BY W.L. SMITH
 CK. BY J.HARRISON
 App. BY W.L. SMITH
 DATE 030306

A-C MOTOR
PERFORMANCE
CURVES
 A36WG0753-R001
 ISSUE DATE 12/15/10

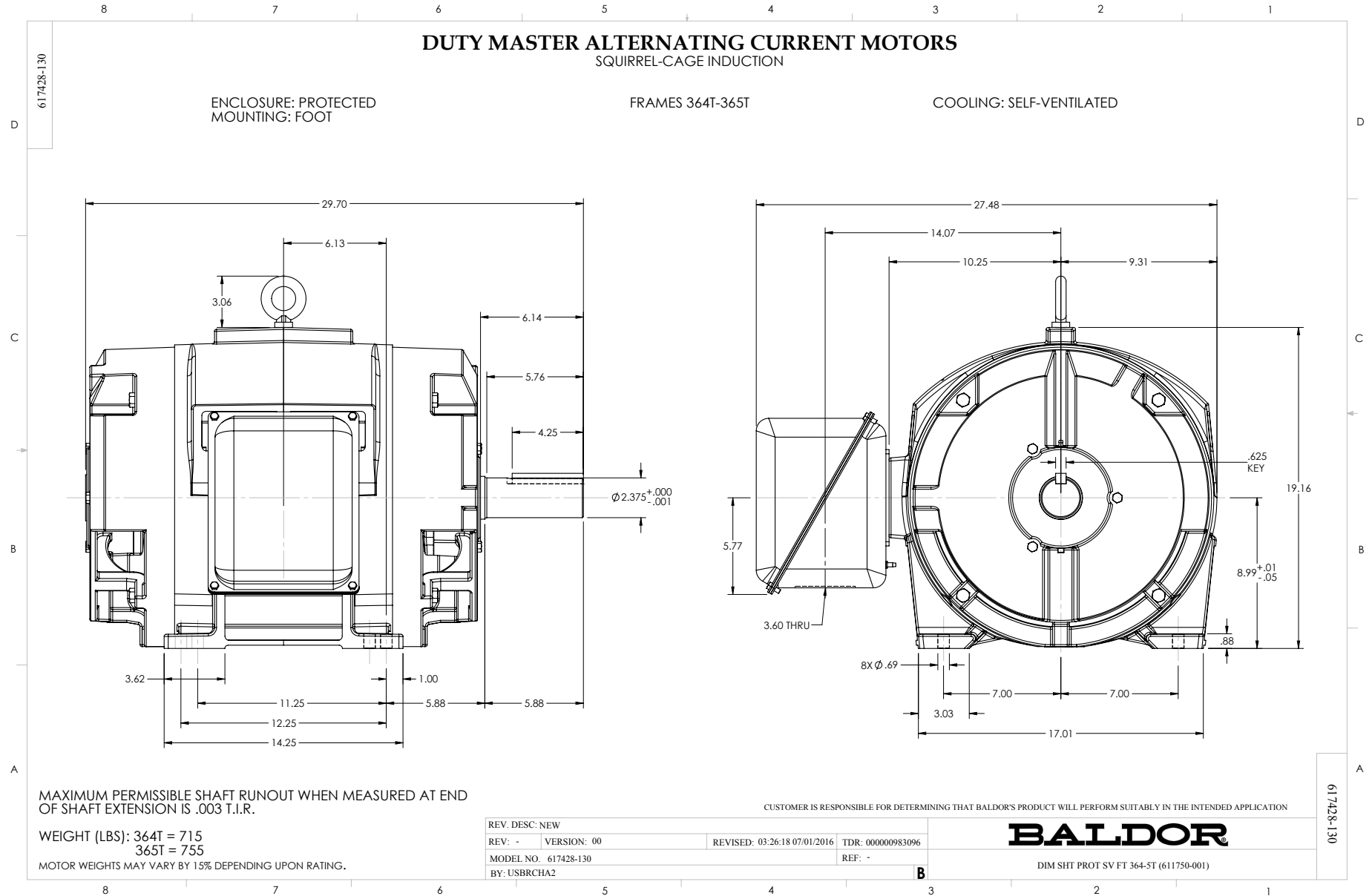

416820-002

A-C MOTOR
 CONNECTION DIAGRAM
 STANDARD 9 LEAD DELTA-CONNECTED

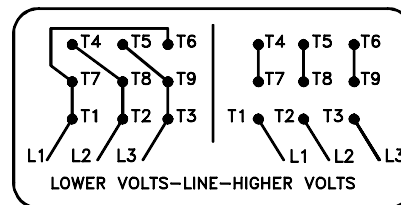
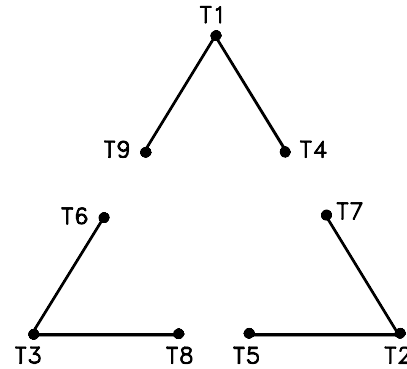

(N.P. 1575-B)

416820-002

REV. DESC: LOADED TO BUS, C/R 335225		
REV. LTR: -	VERSION: 00	TDR: 000000538207
FILE: \MGA\00000\661	REVISED: 10: 47: 51 04/30/2010	
MTL: -	BY: RAGRA	

BALDOR

CONN DIAG - STANDARD 9 LEAD, DELTA-CONNECTED

SH 1 of 1

Marketing maintained PDF of MN408:

<http://www.baldor.com/support/Literature/Load.ashx/MN408?ManNumber=MN408>

Marketing maintained PDF of MN416:

<http://www.baldor.com/support/Literature/Load.ashx/MN416?ManNumber=MN416>