

## Pneumatic Drive Bellows Pump



The right pump for the right job. The FA Series bellows pump addresses low flow and high flow requirements at low to medium temperatures (5 to 100°C). The FA-2E pump is for precise chemical delivery for flow rates up to 0.5 gpm (2 L/min). The FA-40 pump is excellent for applications requiring high volume flow, such as large wafer processing, delivering up to 11.6 gpm (50 L/min). The FA-40 is constructed vertically to optimize precious cabinet space.

All liquid ends are constructed of fluoropolymers for purity and corrosion resistance. The PTFE bellows are rugged and proven to withstand long term continuous operation and high pressure resistance better than any other pump.

Leak detection and drive sensing enhance the reliability and safety of these pneumatic pumps.

Model	FA-2E	FA-40VEW
Maximum discharge capacity	0.5 gal (2 L/min)	10.6 gal (20 L/min)
Maximum stroke speed	150 spm	80 spm
Liquid temperature range	41-212°F (5-100°C)	68-212°F (20-100°C)
Maximum air supply pressure	57 psi (4 kg/cm <sup>2</sup> )	57 psi (4 kg/cm <sup>2</sup> )
Maximum air consumption	13.2 CFM (50 NL/min)	7.1 CFM (200 NL/min)
Pump connection size	PFA 3/8"	PFA 1"
Supply air connection size*	PT 1/4"	PT 3/8"

\*NPT conversion fittings are available



## Performance Curves

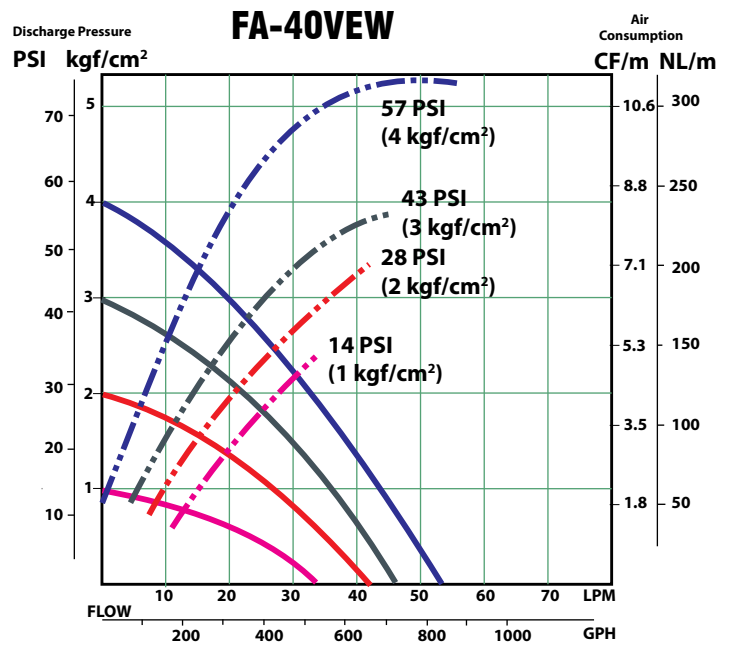
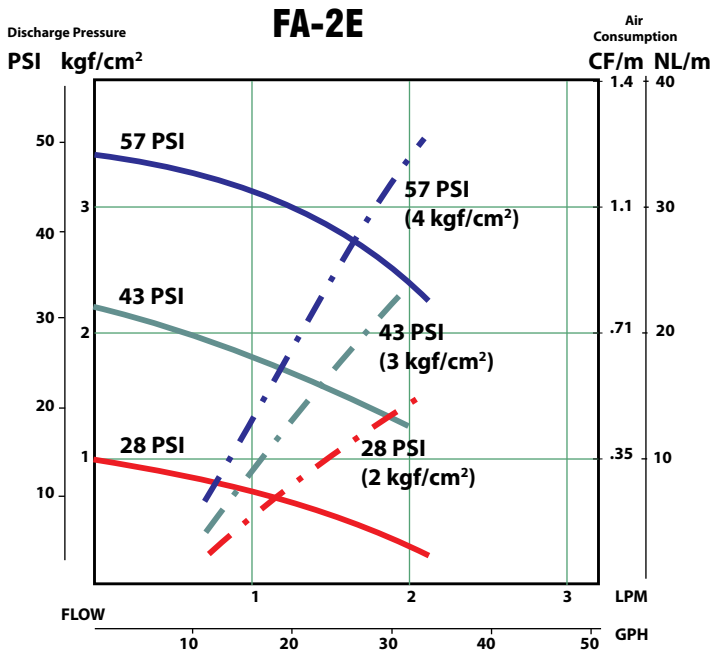

## Dimensions in inches (mm)

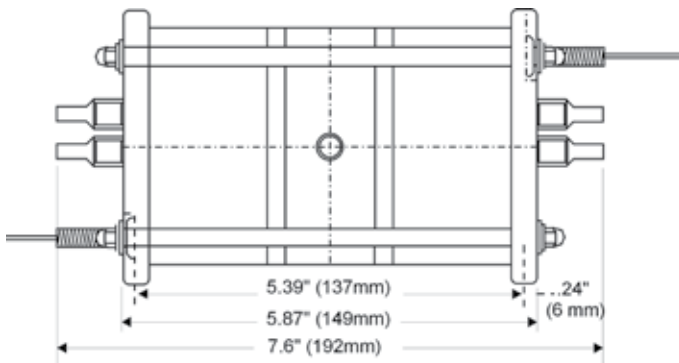

FA-2E

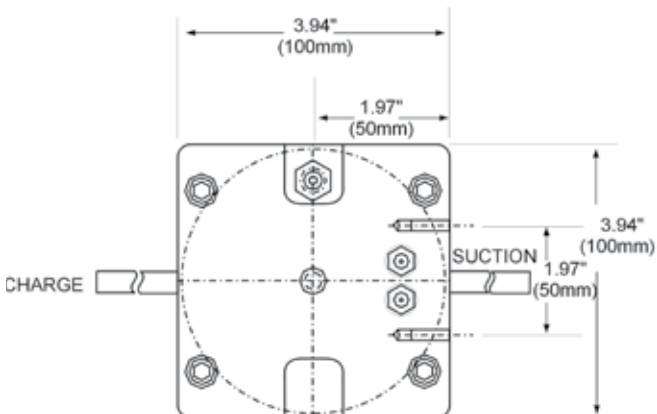

Dimensions subject to change without notice. Consult your local distributor for current information.

