

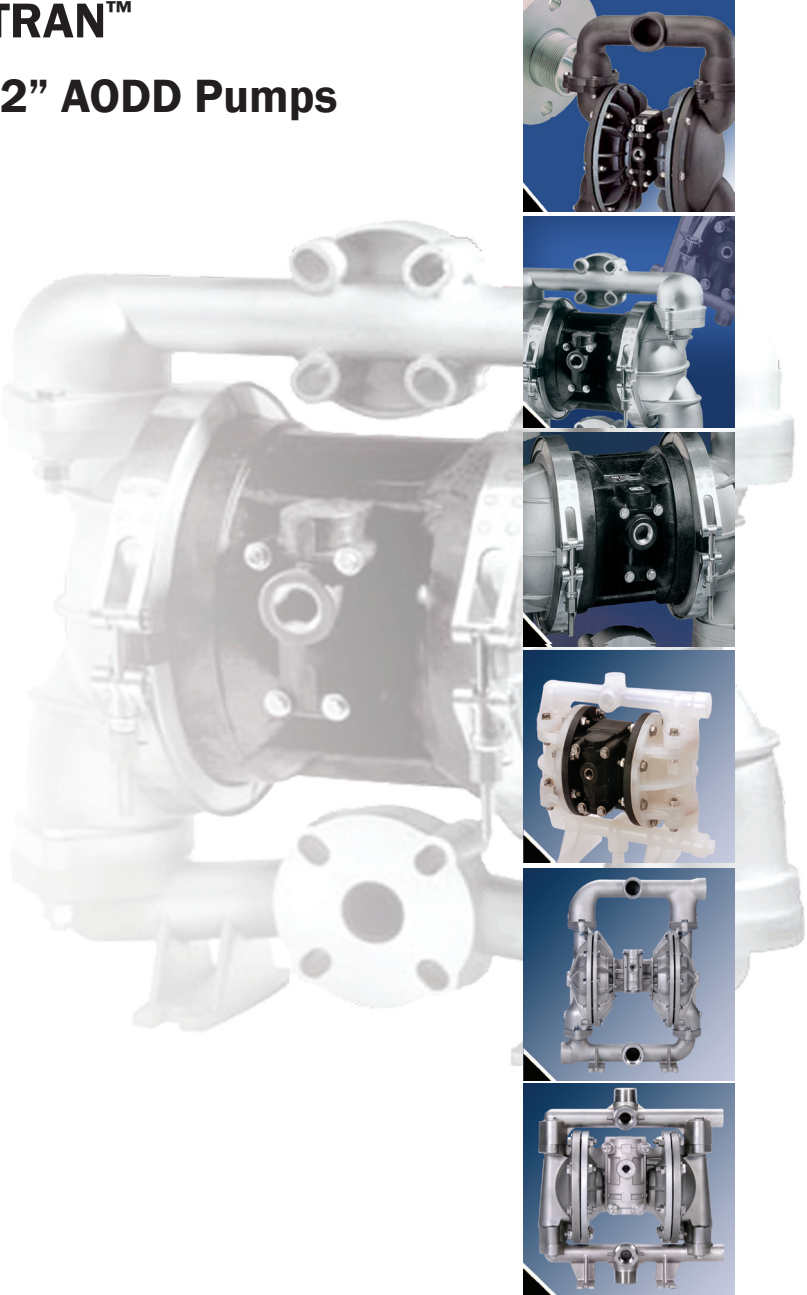

A measured step forward™

AIRTRAN™ 1 1/2" AODD Pumps



Total | Metering
Fluid | Transfer
Management | Chem Feed



Table of Contents

Warnings, Dangers And Cautions	3
Model Designation Matrix & Repair Kits - Clamped Plastic	4
Principles of Operation	5
Dimensional Drawings	6
1-1/2" Pump Dimensions - Clamped Plastic	6
Performance Curves	7
Installation, Troubleshooting and Maintenance	8
Installation.....	8
Troubleshooting.....	10
Operation	11
Maintenance	11
Repair and Assembly	12
Pump Wet End Removal	12
Air Valve Removal.....	14
Pilot Valve Removal.....	16
Torque Specification Chart	17
Exploded View & Parts List	18
Exploded View: Clamped Plastic - LI15-FP*_*_*_*_*_*_*_*	18
Parts List: Clamped Plastic - LI15-FP*_*_*_*_*_*_*_*	19
Parts List: Clamped Plastic - LI15-FP*_*_*_*_*_*_*_* (con't)	20
Elastomers	21

Warnings, Dangers And Cautions

CAUTIONS — Read First!

READ THESE WARNINGS AND SAFETY PRECAUTIONS PRIOR TO INSTALLATION OR OPERATION. FAILURE TO COMPLY WITH THESE INSTRUCTIONS COULD RESULT IN PERSONAL INJURY AND OR PROPERTY DAMAGE. RETAIN THESE INSTRUCTIONS FOR FUTURE REFERENCE.

WARNING Pump, valves and all containers must be properly grounded prior to handling flammable fluids and/or whenever static electricity is a hazard.

WARNING Prior to servicing the pump, ensure that the air and fluid lines are closed and disconnected. While wearing personal protective equipment, flush, drain and process liquid from the pump in a safe manner.

WARNING The TX marking refers to the maximum surface temperature depending not on the equipment itself, but mainly on operating conditions. In this case, the maximum surface temperature depends upon the temperature of the process fluids.

CAUTION The temperature of the process fluid and air input must be no more than 36 °F (20C) less of the maximum temperature allowed for the appropriate non-metallic material. See the list of temperatures below for each material's maximum recommended temperature:

Buna-N (Nitrile):	10 °F to 180 °F (-12C to 82C)
Geolast®:	10 °F to 180 °F (-12C to 82C)
EPDM:	-40 °F to 280 °F (-40C to 138C)
Santoprene®:	-40 °F to 225 °F (-40C to 107C)
Viton® (FKM):	-40 °F to 350 °F (-40C to 177C)
PTFE:	40 °F to 220 °F (4C to 104C)
Polypropylene:	32 °F to 180 °F (0C to 82C)
PVDF:	0 °F to 250 °F (-18C to 181C)
Nylon:	0 °F to 200 °F (-18C to 93C)

Temperature limits are solely based upon mechanical-stress and certain chemicals will reduce the maximum operating temperature. The allowable temperature range for the process fluid is determined by the materials in contact with the fluid being pumped. Consult a chemical resistance guide for chemical compatibility and a more precise safe temperature limit. Always use minimum air pressure when pumping at elevated temperatures.

CAUTION Do not lubricate air supply.

WARNING = Hazards or unsafe practices which could result in severe personal injury, death or substantial property damage

CAUTION = Hazards or unsafe practices which could result in minor personal injury, product or property damage.

CAUTION Do not connect a compressed air source to the exhaust port of the pump.

WARNING Use only with liquid process fluid.

WARNING Maintenance must not be performed when a hazardous atmosphere is present.

CAUTION Do not exceed 120 psig (8.3 bar) air-inlet pressure.

CAUTION Do not exceed 10 psig (0.7 bar) or 23 ft-H₂O suction pressure.

CAUTION Ensure all wetted components are chemically compatible with the process fluid and the cleaning fluid.

CAUTION Ensure pump is thoroughly cleaned and flushed prior to installation into a process line.

CAUTION Always wear Personal Protective Equipment (PPE) when operating pump.

CAUTION Close and disconnect all compressed air and bleed all air from the pump prior to service. Remove all process fluid in a safe manner prior to service.

CAUTION Blow out all compressed air lines in order to remove any debris, prior to pump installation. Ensure that the muffler is properly installed prior to pump operation.

CAUTION Ensure air exhaust is piped to atmosphere prior to a submerged installation.

CAUTION Ensure all hardware is set to correct torque values prior to operation.

Model Designation Matrix & Repair Kits - Clamped Plastic

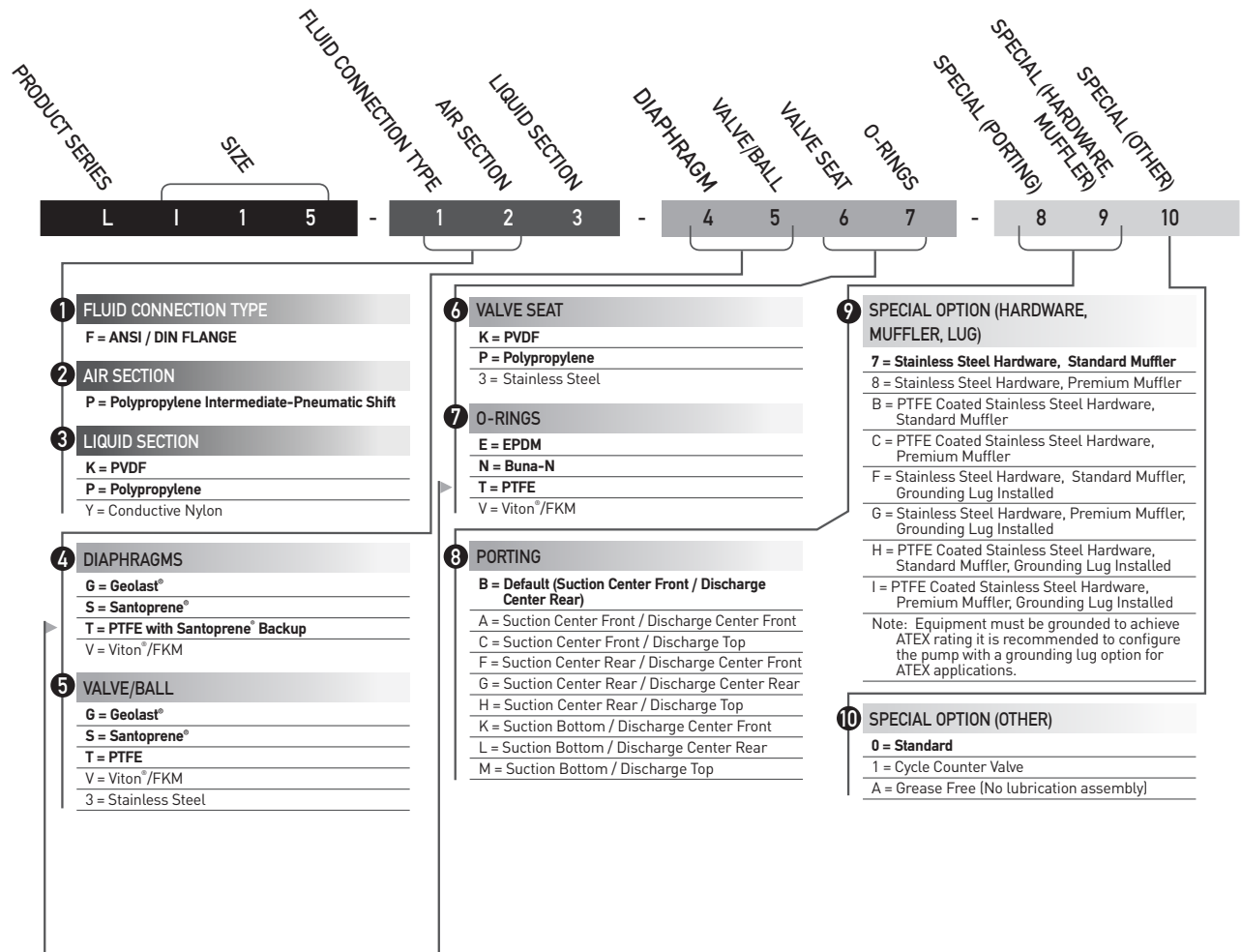

WET END REPAIR KIT

Wet end kits are available and consist of diaphragms, (back-up diaphragms if required), balls, seats and seat O-Rings. See matrix below.



AIR END REPAIR KIT

Air end repair kit contains pilot sleeve assembly and main air valve.

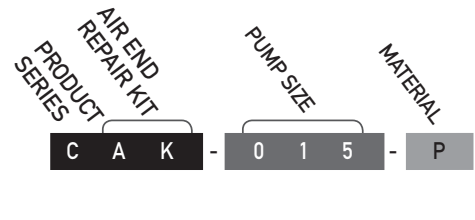

Principles of Operation

How an Air Operated Double Diaphragm Pump Works

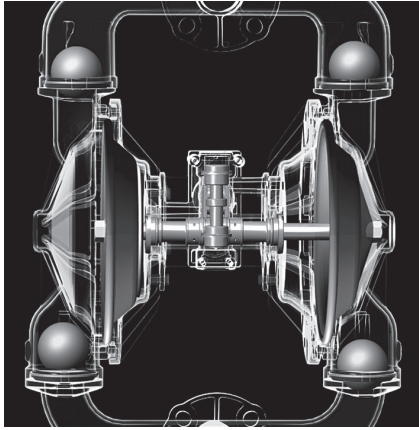

The air-valve directs pressurized air behind the diaphragm on the right, causing the diaphragm on the right to move outward (to the right).

Since both the right diaphragm and the left diaphragm are connected via a diaphragm rod, when the right diaphragm moves to the right, the left diaphragm (through the action of the diaphragm rod) moves to the right also.

When the diaphragm on the left side is moving to the right, it is referred to as suction stroke. When the left diaphragm is in its suction stroke, the left suction ball moves upward (opens) and the left discharge ball moves downward (closes). This action creates suction and draws liquid into the left side chamber.

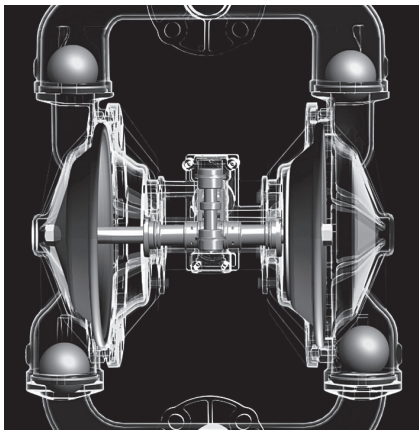

The air-valve directs pressurized air behind the left diaphragm, causing the left diaphragm to move outward (to the left).

Since both the left diaphragm and the right diaphragm are connected via a diaphragm rod, when the left diaphragm moves to the left, the right diaphragm (through the action of the diaphragm rod) moves to the left also.

When the diaphragm on the left side moves outward, the left discharge ball moves upward (opens) and the left suction ball moves downward (closes). This causes the liquid to leave the left side liquid outlet of the pump.

Simultaneously, the right diaphragm moves inward (to the left), which causes the right suction ball to open and the right discharge to close, which in turn causes suction, drawing liquid into the right chamber.

The process of alternating right suction / left discharge (and vice-versa) continues as long as compressed air is supplied to the pump.

Dimensional Drawings

1-1/2" Pump Dimensions - Clamped Plastic

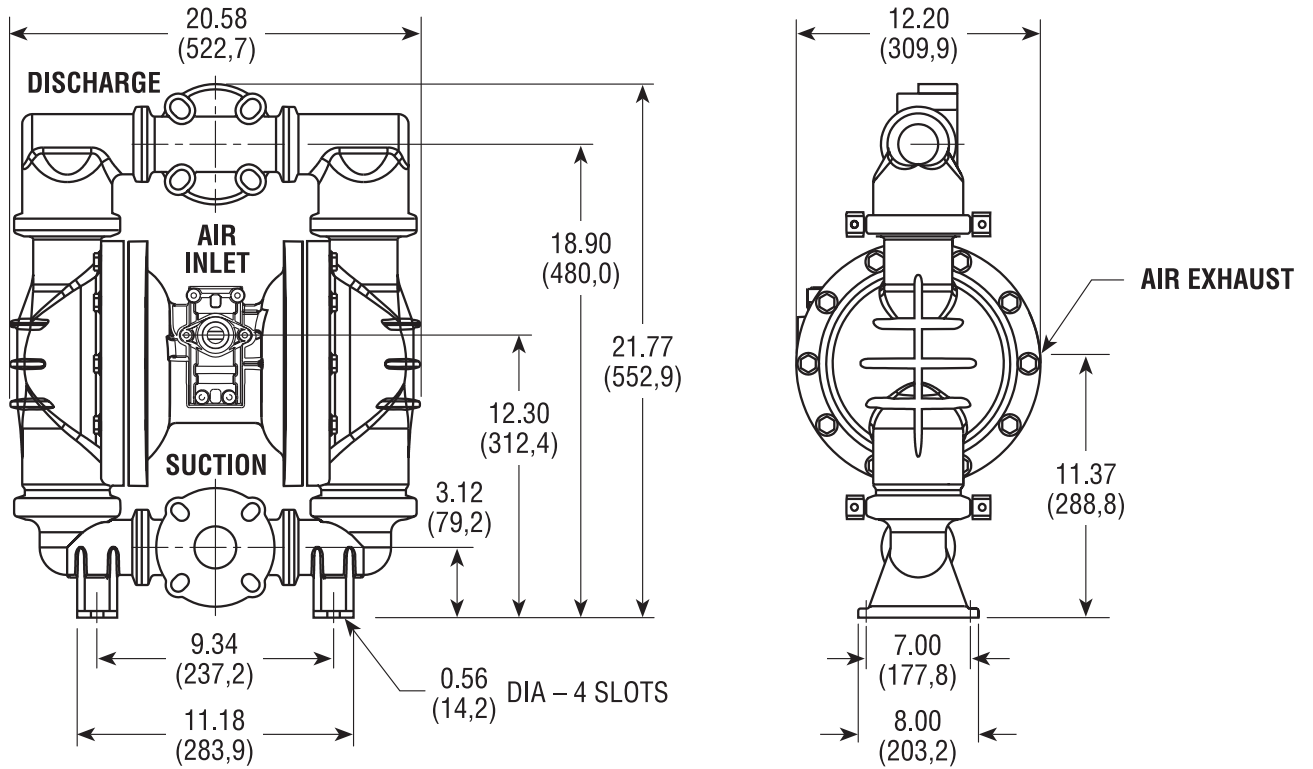

Dimensions in inches (mm)

Performance Curves

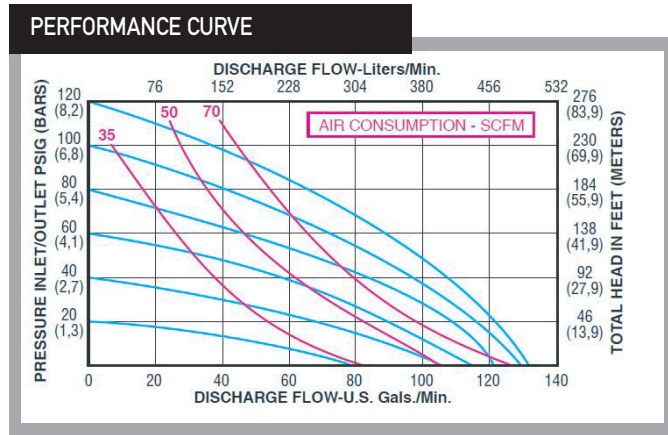

Performance Specifications

Max. Flow:	130 gpm (492 lpm)
Max. Air Pressure:	120 psi (8.2 bar)
Max. Solids:	1/4" (6.4 mm)
Max. Suction Lift Dry:	15 ft-H ₂ O (4.6 m-H ₂ O)
Max. Suction Lift Dry w/PTFE:	10 ft-H ₂ O (3.0 m-H ₂ O)
Max. Suction Lift Wet:	26 ft-H ₂ O (7.9 m-H ₂ O)
Weight Polypropylene:	46 lbs (20.8 kg)
Weight PVDF:	65 lbs (29.4 kg)
Air Inlet:	3/4" FNPT
Liquid Inlet:	1 1/2" ANSI / DIN FLANGE
Liquid Outlet:	1 1/2" ANSI / DIN FLANGE
Height:	21.77" (552.9 mm)
Width:	20.58" (522.7 mm)
Depth:	12.20" (309.9 mm)

*Flow rates indicated on the chart(s) shown were determined by pumping water at flooded suction. For optimum life and performance, pumps should be specified so that daily operation parameters will fall in the center of the pump performance curve.

Installation, Troubleshooting and Maintenance

Installation

Piping

Whenever possible ensure the pump is installed using the shortest possible pipe lengths with the minimum amount of pipe fittings. Ensure all piping is supported independent of the pump.

Suction and discharge piping should not be smaller than the connection size of the pump. When pumping liquids of high viscosity, larger piping may be used, in order to reduce frictional pipe loss.

Employ flexible hoses in order to eliminate the vibration caused by the pump. Mounting feet can also be used to reduce vibration effects.

All hoses should be reinforced, non-collapsible and be capable of high vacuum service. Ensure that all piping and hoses are chemically compatible with the process and cleaning fluid.

For processes where pulsation effects should be reduced, employ a pulsation dampener on the discharge side of the pump.

For self-priming applications, ensure all connections are airtight and the application is within the pumps dry-lift capability. Refer to product specifications for further details.

For flooded suction applications, install a gate valve on the suction piping in order to facilitate service.

For unattended flooded suction operation, it is recommended to pipe the exhaust air above the liquid source. In the event of a diaphragm failure this will reduce or eliminate the possibility of liquid discharging through the exhaust onto the ground.

Location

Ensure that the pump is installed in an accessible location, in order to facilitate future service and maintenance.

Air

Ensure that the air supply is sufficient for the volume of air required by the pump. Refer to product specifications for further details. For reliable operation, install a 5 micron air filter, air-valve and pressure regulator. Do not exceed the pumps maximum operating pressure of 120 psig.

Remote Operation

Utilize a three way solenoid valve for remote operation. This ensures that air between the solenoid and the pump is allowed to "bleed off," ensuring reliable operation. Liquid transfer volume is estimated by multiplying displacement per stroke times the number of strokes per minute

Noise

Correct installation of the muffler reduces sound levels. Refer to product specifications for further details.

Submerged Operation

For submersible operation, pipe the air exhaust to atmosphere

Grounding the Pump

Loosen grounding screw and install a grounding wire. Tighten grounding screw. Wire size should be a 12 gauge wire or larger. Connect the other end of the wire to a true earth ground. Equipment must be grounded to achieve ATEX rating and it is recommended to configure the pump with a grounding lug option.



Suggested Installation

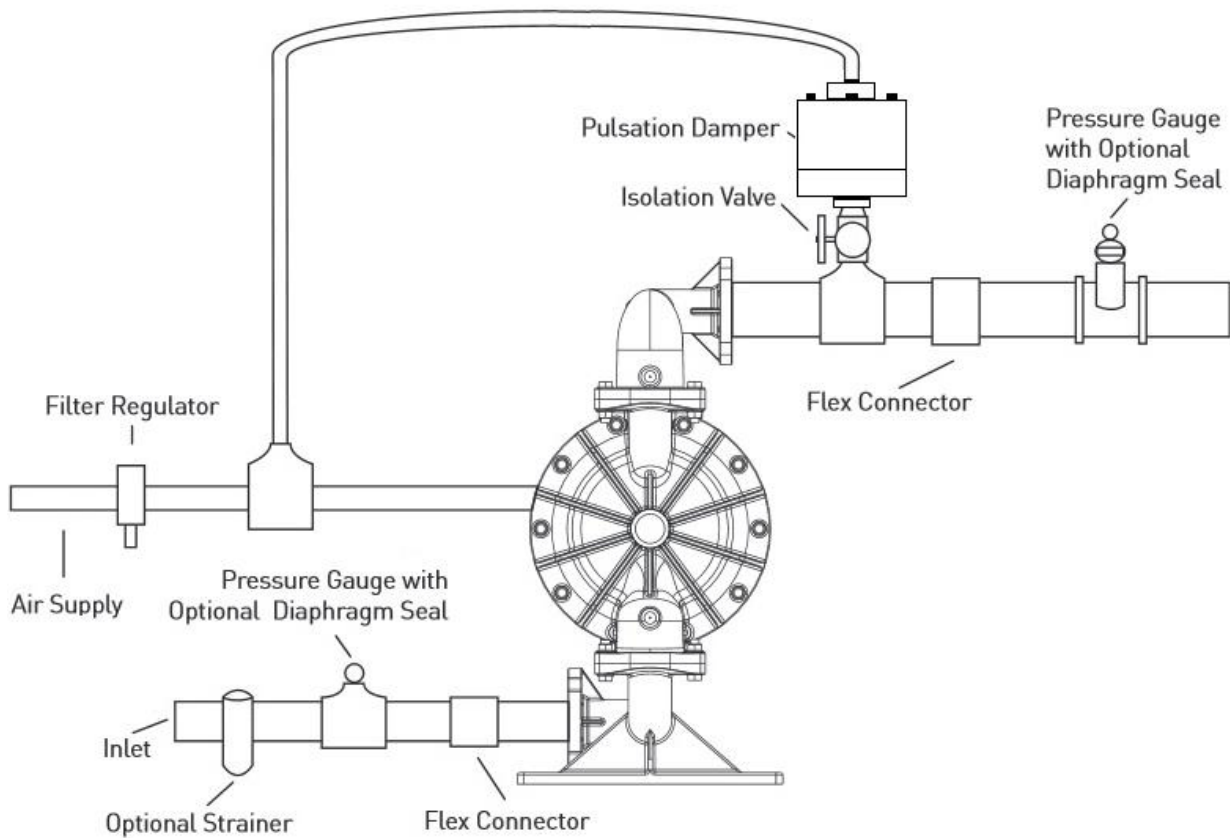

This illustration is a generic representation of an air operated double-diaphragm pump.



Troubleshooting

Problem	Effect/Solution
Pump Will Not Cycle	<ul style="list-style-type: none"> Discharge line closed or plugged Discharge filter blocked Check valve stuck Air filter blocked Air supply valve closed Air supply hooked up to muffler side of pump Compressor not producing air or turned off Muffler iced or blinded Diaphragm ruptured Plant air supply lines ruptured Air valve wear/debris Pilot sleeve wear/debris Diaphragm rod broken Diaphragm plate loose
Pumped Fluid Coming Out of Muffler	<ul style="list-style-type: none"> Diaphragm ruptured Diaphragm plate loose Inlet liquid pressure excessive (above 10 psig)
Pump Cycles but no Flow	<ul style="list-style-type: none"> Inlet strainer clogged Suction valve closed Suction line plugged No liquid in the suction tank Suction lift excessive Debris stuck in valves Excessive wear of check valves Air leak on suction side with suction lift
Pump Cycles with Closed Discharge Valve	<ul style="list-style-type: none"> Debris stuck in check valve Excessive wear of check valves
Pump Running Slowly/Not Steady	<ul style="list-style-type: none"> Air compressor undersized Leak in air supply Air-line, filter regulator or needle valve undersized Muffler partially iced or blinded Air valve gasket leak or misalignment Air valve wear/debris Pilot sleeve wear/debris Liquid fluid filter blocked Pump may be cavitating, reduce speed of operation Suction strainer clogged
Pump Will Not Prime	<ul style="list-style-type: none"> Air leak in suction pipe Air leak in pump manifold connections Suction strainer and lines clogged Excessive lift conditions Check valve wear Debris in check valve

Operation

The Air-Operated Double Diaphragm Pump requires a minimum of 20 psig of air to operate, with some variation according to diaphragm material. Increasing the air pressure results in a more rapid cycling of the pump and thus a higher liquid flow rate. In order to not exceed 120 psig of inlet air pressure, and for accurate control of the pump, it is suggested to use a pressure regulator on the air inlet.

An alternate means of controlling the flow-rate of the pump is to use an inlet air valve and partially open or close accordingly. When the air valve is completely in the closed position, the pump will cease to operate.

A third method of controlling the flow rate of the pump is to use a liquid discharge valve. Closing the liquid discharge valve will cause a decrease in the flow rate since the pump will operate against a higher discharge pressure.

Solenoid control of the inlet air may also be used in order to facilitate remote operation. A three way solenoid valve is recommended, in order to allow the air to “bleed off” between the solenoid and the pump.

Do not use valves for flow control on the suction side of the pump. (Closing or partially closing a liquid suction valve restrict the suction line and may cause damage to the diaphragms.) Suction strainers may be employed to reduce or eliminate larger solids, but routine maintenance is necessary in order to prevent a restriction on the suction.

Maintenance

Due to the unique nature of each application, periodic inspection of the pump is the best method to determine a proper maintenance schedule. A record should be kept of all repairs made to an installed pump. This will serve as the best predictor of future maintenance.

Typical maintenance involves replacing of “wear-parts” such as the diaphragms, balls, valve seats and O-rings. Proper maintenance can ensure trouble-free operation of the pump. Refer to repair and assembly instructions for further details.

 **WARNING** Maintenance must not be performed when a hazardous atmosphere is present.

Maintenance Schedule

Weekly (or daily)

Make a visual check of the pump. If pumped fluid is leaking out of the pump, pipe fittings or muffler turn off pump and schedule maintenance.

Every three months

Inspect fasteners and tighten any loose fasteners to recommended torque settings.

Schedule pump service based on pump’s service history.

Repair and Assembly

Pump Wet End Removal

Tools needed

- 1) One Wrench, 1/2 Inch
- 2) Two Wrenches, 3/4 Inch
- 3) Two Wrenches, 1 1/4 Inch

⚠ WARNING Prior to servicing the pump, ensure that the air and fluid lines are closed and disconnected. While wearing personal protective equipment, flush, drain and process liquid from the pump in a safe manner.

⚠ WARNING Maintenance must not be performed when a hazardous atmosphere is present.

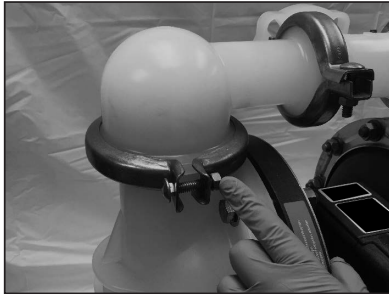

STEP 1

In order to remove the "Discharge Manifold", using the 1/2 inch wrench, remove the top "Chamber Clamps" from each of the "Chambers".

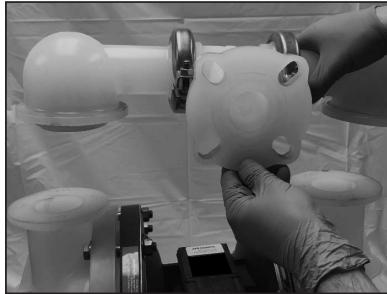

STEP 2

Remove the "Discharge Manifold".

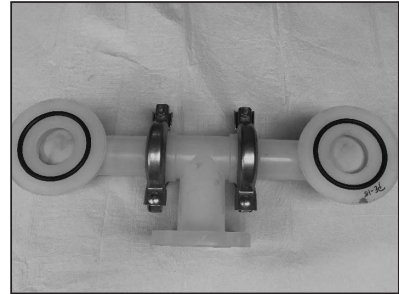

STEP 3

Remove the "O-Ring", "Valve Seat" and "Ball" from "Discharge Manifold".

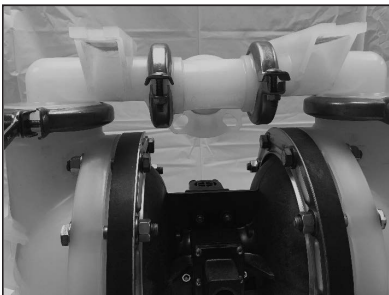

STEP 4

In order to remove the "Suction Manifold", using the 1/2 inch wrench, remove the bottom "Chamber Clamps" from each of the "Chambers".

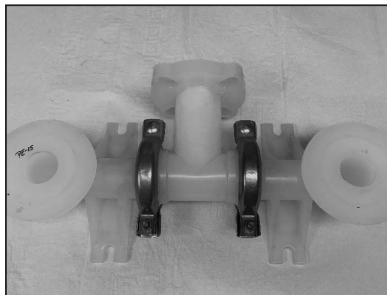

STEP 5

Remove the "Suction Manifold".



STEP 6

Remove the "O-Ring", "Valve Seat" and "Ball" from the "Outer Chambers".

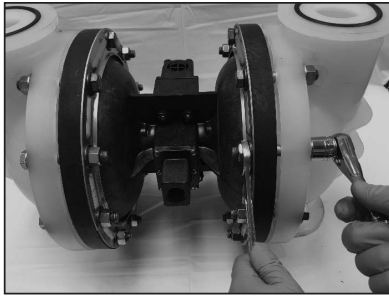

STEP 7

In order to remove both “Outer Chambers”, using two $\frac{3}{4}$ Inch wrenches (or socket), remove ten “Hex Head Cap Screws”, “Washers”, “Compression Washers” and “Nuts” from each side. Note the lower four bolts are inserted from the center.



STEP 8

Remove both “Outer Chambers” and “Power Rings” from the “Intermediate”. Note the “Compression Washers” cup face should be toward the “Power Ring”.



STEP 9

Using two $1\frac{1}{4}$ inch wrenches, remove “Outer Diaphragm Plate”, “Diaphragm”, “Inner Diaphragm Plate” and “Custom Washer” from one side of the pump.



STEP 10

Placing the $1\frac{1}{4}$ inch wrench on the remaining “Outer Diaphragm Plate”, and the $\frac{3}{4}$ inch wrench on the “Diaphragm Rod Assembly”, remove the remaining “Outer Diaphragm Plate”, “Diaphragm”, “Inner Diaphragm Plate” and “Custom Washer” from the other side of the pump.

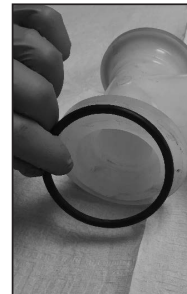

STEP 11

Using the $\frac{1}{2}$ inch wrench, remove the center “Manifold Clamps” from each of the “Elbows”. Remove the “O-Ring”.

Pump Wet End Assembly

To assemble the wet end of the pump, reverse the order of disassembly. Ensure all hardware is fastened in accordance with torque specifications (see page 17). Inverting one of the diaphragms during reassembly will facilitate ease of assembly.

When positioning band clamps use soapy water or a compatible lubricating spray on the inside of band clamps to aid assembly. Tap with a mallet on the outside of clamp to help position the clamp while tightening the fasteners. The band clamp fasteners and cap screws are stainless steel. To prevent galling always apply an anti-seize compound to the thread.

NOTE: When using pumps built with PTFE O-Rings, always replace with new PTFE O-Rings, since the original O-Rings may not reseal the pump.

Repair and Assembly

Air Valve Removal

Tools needed

- 1) One Wrench, 7/16 Inch
- 2) One Pick, General Purpose
- 3) One Pair of Pliers

⚠ WARNING Prior to servicing the pump, ensure that the air and fluid lines are closed and disconnected. While wearing personal protective equipment, flush, drain and process liquid from the pump in a safe manner.

⚠ WARNING Maintenance must not be performed when a hazardous atmosphere is present.

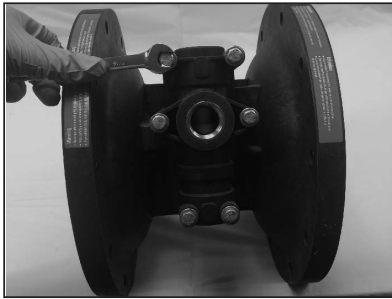

STEP 1

Using the 7/16 inch wrench, remove six "Hex Head Cap Screws" "Lock Washers", "Flat Washers" and "Hex Nuts (rear)".



STEP 2

Remove the main "Air-Valve Assembly" from the pump.

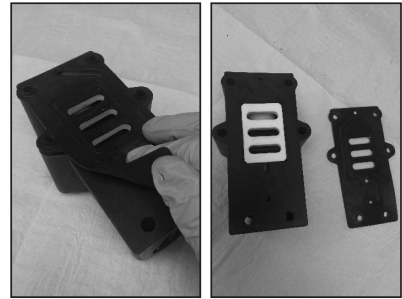

STEP 3

Remove the "Air-Valve Gasket" from the main "Air-Valve Assembly".

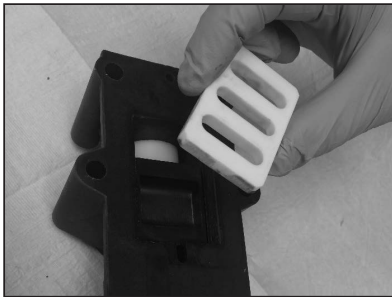

STEP 4

Remove the "Shuttle Plate" from the main "Air-Valve Assembly".

Note: The smooth shiny side of the shuttle plate should be toward the shuttle car.

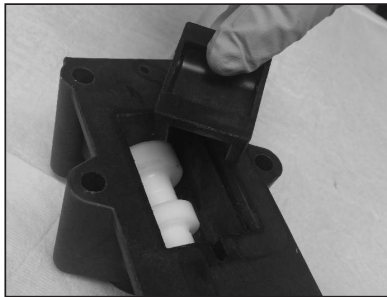

STEP 5

Remove the "Shuttle" from the main "Air-Valve Assembly".

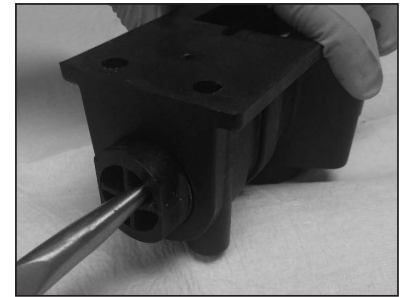

STEP 6

Using the pair of pliers, remove the "Air Valve End Plug" from the main "Air-Valve Assembly".

Ensure the "O-Ring" is installed when reassembling.

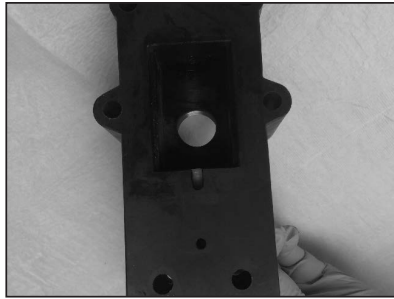

STEP 7

Remove the “Air Valve Spool” from the main “Air-Valve Assembly”.

Note: The longer piston with the boss is on the plug side, insert larger chamfer first.

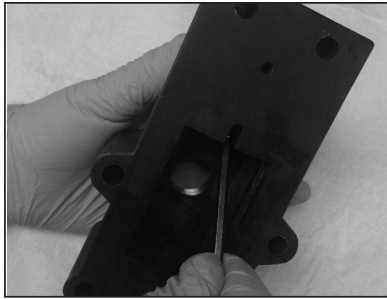

STEP 8

Using the pick, remove the “Lip Seal (Air Valve)” from the main “Air-Valve Assembly”.

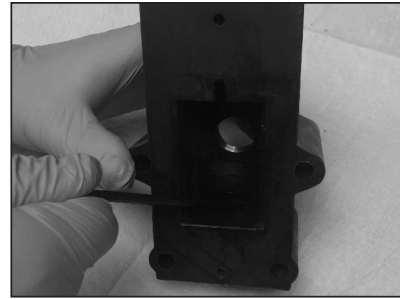

STEP 9

Using the pick, remove the second “Lip Seal (Air Valve)” from the main “Air-Valve Assembly”.

Air Valve Assembly

To assemble the air valve, reverse the order of disassembly. During assembly, ensure that the open side of the lip-seals are both facing each other inward. Install the shuttle plate with the smooth/shiny side toward the shuttle car. Lubrication of the air valve assembly, with a non-synthetic lubricant, is recommended. Magna-Lube or Magna-Plate are recommended for assembly lubrication (see detailed parts list for ordering information).

Note that if the lip-seals are installed incorrectly, they will be unable to rotate. Insert the spool, larger chamfer side first, the spool’s longer piston with the boss is to be on the plug side, ensure O-Ring is installed, and then the air-valve end plug into position.

Repair and Assembly

Pilot Valve Removal

Tools needed

- 1) One Screwdriver, Phillips #2
- 2) Two Wrenches, 3/4 Inch

⚠ WARNING Prior to servicing the pump, ensure that the air and fluid lines are closed and disconnected. While wearing personal protective equipment, flush, drain and process liquid from the pump in a safe manner.

⚠ WARNING Maintenance must not be performed when a hazardous atmosphere is present.



STEP 1

Using the screwdriver, remove three "Phillips Pan-Head Screws" in order to remove the "Retaining Plate". Repeat for other side of the pump.



STEP 2

Remove the "Diaphragm Rod" and the "Pilot Sleeve Assembly" from the "Intermediate".

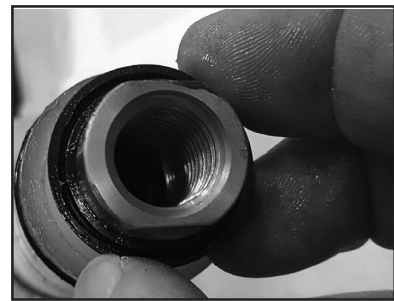

STEP 3

Remove both "Lip Seals (Diaphragm Rod)" and both "End Spacers (Pilot Sleeve)" from the "Pilot Sleeve Assembly". Remove both "O-Rings (End Spacer)" from both "End Spacers (Pilot Sleeve)".

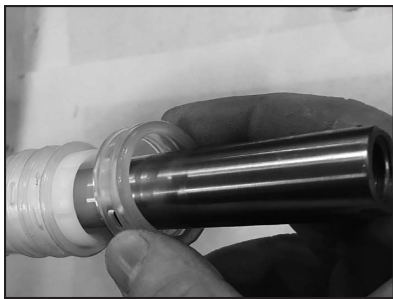

STEP 4

Remove three "Inner Spacers (Pilot Sleeve)" and four "O-Rings (Pilot Sleeve)" from the "Pilot Sleeve Assembly".



STEP 5

Using two 3/4 inch wrenches, disassemble the "Diaphragm Rod Assembly" into its two parts.

Note: They are installed with thread locker.



STEP 6

Remove "Pilot Sleeve" from the disassembled "Diaphragm Rod Assembly".

Pilot Valve Assembly

To assemble the pilot valve, reverse the order of disassembly. Should process fluid have contact with the pilot valve O-rings, they should be replaced as swelling may occur and cause irregular operation. During assembly, ensure that the open side of the lip-seals are facing outward. Lubrication of the pilot sleeve assembly, with a non-synthetic lubricant, is recommended in order to facilitate re-assembly into the intermediate. Magna-Lube or Magna-Plate are recommended for assembly lubrication (see detailed parts list for ordering information).

Torque Specification Chart

Recommended Torque Specifications

1.5" Pumps	
Band Clamps (Manifolds)	80 in-lbs (9.04 N-m)
Band Clamps (Chambers)	80 in-lbs (9.04 N-m)
Chamber Bolts	15 ft-lbs (20.34 N-m)
Air Valve Bolts	40 in-lbs (4.52 N-m)
Diaphragm Plates	372 in-lbs (42.0 N-m)

Note: Always torque the chamber bolts prior to the manifold bolts. When reassembling, loosely tighten all external fasteners adjusting and aligning gradually, in an alternating fashion, tighten to torque requirements listed above.

Note: When using pumps built with PTFE O-Rings, always replace with new PTFE O-Rings, since the original O-Rings may not reseal the pump.

Exploded View & Parts List

Exploded View: Clamped Plastic - LI15-FP*.*.*.*.*

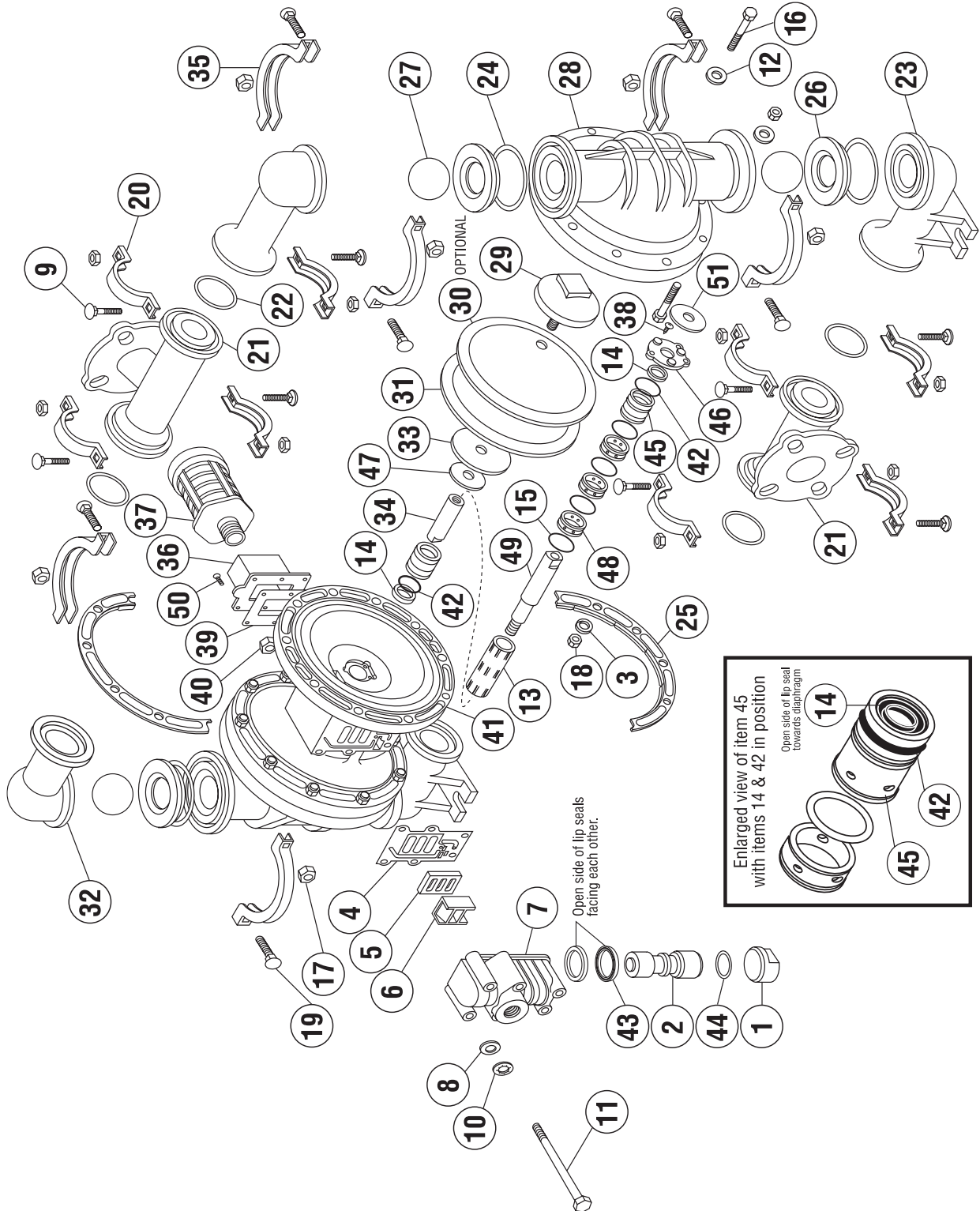

Parts List: Clamped Plastic - LI15-FP*-****-***

ITEM	DESCRIPTION	QTY	PUMP MODEL	PART NO.	MATERIAL
1	AIR VALVE END PLUG	1	ALL MODELS	11703-60	Polypropylene
2	AIR VALVE SPOOL	1	ALL MODELS	10481-31	Acetal
3	COMPRESSION WASHER (1/2")	20	ALL MODELS (NON-PTFE COATED)	12319-26	Stainless Steel
4	AIR VALVE GASKET	1	ALL MODELS	12121-19	Nitrile
5	SHUTTLE PLATE	1	ALL MODELS	10450-77	Ceramic
6	SHUTTLE	1	ALL MODELS	10430-00	Special
7	AIR VALVE BODY	1	ALL MODELS	11617-60	Polypropylene
8	FLAT WASHER (1/4")	6	ALL MODELS (NON-PTFE COATED)	12300-26	Stainless Steel
9	CARR. BOLT (5/16" X 1-1/2")	8	ALL MODELS (NON-PTFE COATED)	12509-26	Stainless Steel
10	LOCK WASHER (1/4")	6	ALL MODELS (NON-PTFE COATED)	12350-26	Stainless Steel
11	CAP SCREW (1/4" X 6")	6	ALL MODELS (NON-PTFE COATED)	12515-26	Stainless Steel
12	FLAT WASHER (1/2")	20	ALL MODELS (NON-PTFE COATED)	12306-26	Stainless Steel
13	PILOT SLEEVE	1	ALL MODELS	10106-31	Acetal
14	LIP SEAL (Diaphragm Rod)	2	ALL MODELS	12002-76	Nitrile
15	O-RING (End Spacer)	4	ALL MODELS	11919-16	Urethane
16	CAP SCREW (1/2" X 3 1/4")	20	ALL MODELS (NON-PTFE COATED)	12555-26	Stainless Steel
17	HEX NUT (5/16" - 18)	16	ALL MODELS (NON-PTFE COATED)	12601-26	Stainless Steel
18	HEX NUT (1/2" - 13)	20	ALL MODELS (NON-PTFE COATED)	12604-26	Stainless Steel
19	CARR. BOLT (5/16 X 2")	8	ALL MODELS (NON-PTFE COATED)	12529-26	Stainless Steel
20	CLAMP (Manifold) (Complete With Fasteners)	4	ALL MODELS (NON-PTFE COATED)	12901-26	Stainless Steel
21	MANIFOLD	2	LI15-FPP-****-*** LI15-FPK-****-***	10581-40 10581-56	Polypropylene PVDF
22	O-RING (Manifold)	4	LI15-FP*-***N-*** LI15-FP*-***V-*** LI15-FP*-***E-*** LI15-FP*-***T-***	11922-11 11922-13 11922-15 11922-17	Nitrile Viton®/FKM EPDM PTFE
23	SUCTION ELBOW	2	LI15-FPP-****-*** LI15-FPK-****-***	10803-40 10803-56	Polypropylene PVDF
24	O-RING (Valve Seat)	4	LI15-FP*-***N-*** LI15-FP*-***V-*** LI15-FP*-***E-*** LI15-FP*-***T-***	11926-11 † 11926-13 † 11926-15 † 11926-17 †	Nitrile Viton®/FKM EPDM PTFE
25	POWER RING (Set)	2	ALL MODELS (NON-PTFE COATED)	12812-26SET	Stainless Steel
26	VALVE SEAT	4	LI15-FP*-**3*-*** LI15-FP*-**P*-*** LI15-FP*-**K*-***	10918-26 † 10918-40 † 10918-56 †	Stainless Steel Polypropylene PVDF
27	BALL	4	LI15-FP*-*V*-*** LI15-FP*-*G*-*** LI15-FP*-*S*-*** LI15-FP*-*3*-*** LI15-FP*-*T*-***	11004-13 † 11004-19 † 11004-23 † 11004-26 † 11004-45 †	Viton®/FKM Geolast® Santoprene® Stainless Steel PTFE
28	OUTER CHAMBER	2	LI15-FPP-****-*** LI15-FPK-****-***	10724-40 10724-56	Polypropylene PVDF



Parts List: Clamped Plastic - LI15-FP*-**-*** (con't)**

ITEM	DESCRIPTION	QTY	PUMP MODEL	PART NO.	MATERIAL
29	OUTER DIAPHRAGM PLATE	2	LI15-FPP-****-*** LI15-FPK-****-***	11203-40 11203-56	Polypropylene PVDF
30	OVERLAY (PTFE ONLY)	2	LI15-FP*-T***-***	11403-59 †	PTFE
31	DIAPHRAGM	2	LI15-FP*-V***-*** LI15-FP*-G***-*** LI15-FP*-S***-*** LI15-FP*-T***-***	10603-13 † 10603-19 † 10603-23 † 10603-23 †	Viton®/FKM Geolast® Santoprene® Santoprene®
32	DISCHARGE ELBOW	1	LI15-FPP-****-*** LI15-FPK-****-***	11306-AF-40 11306-AF-56	Polypropylene PVDF
33	INNER DIAPHRAGM PLATE	2	ALL MODELS	11103-25	Plated Steel
34	DIAPHRAGM ROD (Short)	1	ALL MODELS	*	Stainless Steel
35	CLAMP (Elbow) (Complete With Fasteners)	4	ALL MODELS (NON-PTFE COATED)	12900-26	Stainless Steel
36	MUFFLER PLATE	1	ALL MODELS	13107-60	Polypropylene
37	MUFFLER	1	ALL MODELS	13001-00	Polypropylene
38	SCREW (#6 X 3/4")	6	ALL MODELS	12549-26	Stainless Steel
39	GASKET (Muffler Plate)	1	ALL MODELS	12108-11	Nitrile
40	HEX NUT (1/4" - 20)	6	ALL MODELS (NON-PTFE COATED)	12600-26	Stainless Steel
41	INTERMEDIATE	1	ALL MODELS	11524-60	Polypropylene
42	O-RING (End Spacer)	2	ALL MODELS	11919-11	Nitrile
43	LIP SEAL (Air Valve)	2	ALL MODELS	12003-76	Nitrile
44	O-RING (Valve Plug)	1	ALL MODELS	11913-11	Nitrile
45	END SPACER (Pilot Sleeve)	2	ALL MODELS	10206-40	Polypropylene
46	RETAINING PLATE	2	ALL MODELS	12709-54	Nylon
47	FLAT WASHER (Rod Assembly)	2	ALL MODELS	12315-25	Plated Steel
48	INNER SPACER (Pilot Sleeve)	3	ALL MODELS	10205-40	Polypropylene
49	DIAPHRAGM ROD (Long)	1	ALL MODELS	*	Stainless Steel
50	SCREW (#8 X 3/4")	6	ALL MODELS (NON-PTFE COATED)	12540-26	Stainless Steel
51	BUMPER	2	ALL MODELS	12317-16	Urethane

* Any Character

* NOTE: DIAPHRAGM ROD CAN ONLY BE PURCHASED AS AN ASSEMBLY.

DIAPHRAGM ROD ASSEMBLY Items 34 & 49	1	ALL MODELS	35000-00	Stainless Steel
---	---	------------	----------	-----------------

OPTIONAL ASSEMBLIES AVAILABLE

AIR VALVE ASSEMBLY Items 1, 2, 4, 5, 6, 7, 43, 44	1	ALL MODELS	AMK-150-P	Various
--	---	------------	-----------	---------

PILOT VALVE ASSEMBLY Items 13, 14, 15, 42, 45, 48	1	ALL MODELS	APK-150-P	Various
--	---	------------	-----------	---------

† WET END ASSEMBLY Items 24, 26, 27, 30, 31	1	ALL MODELS	CWE-150-P	Various
--	---	------------	-----------	---------

Elastomers

BUNA-N (NITRILE)

is a general purpose elastomer used with water and many oils. Temperature range 10°F to 180°F (-12C to 82C).

GEOLAST®

is an injection molded thermoplastic material with characteristics similar to Nitrile. Has excellent abrasion resistance. Temperature range 10°F to 180°F (-12C to 82C).

EPDM

is a general purpose elastomer with good resistance to many acids and bases. Temperature range -40°F to 280°F (-40C to 138C).

SANTOPRENE®

is an injection molded material with characteristics similar to EPDM. Has excellent abrasion resistance. Temperature range -40°F to 225°F (-40C to 107C).

VITON®

is an elastomer with good corrosion resistance to a wide variety of chemicals. Temperature range -40°F to 350°F (-40C to 177C).

FKM

is an elastomer with good corrosion resistance to a wide variety of chemicals. Similar in chemical resistance to Viton®. Temperature range -40°F to 350°F (-40C to 177C).

PTFE (POLYTETRAFLUOROETHYLENE)

is a thermoplastic polymer that is inert to most chemicals. Similar in chemical resistance to Teflon®. Temperature range 40°F to 220°F (4C to 104C).

Most of the above elastomers are available in FDA approved formulations.

Viton® is a registered trademark of DuPont Performance Elastomers L.L.C.
Geolast® is a registered trademark of ExxonMobil Chemical Co.
Santoprene® is a registered trademark of ExxonMobil Chemical Co.
Teflon® is a registered trademark of DuPont Performance Elastomers L.L.C.
Hytrel® is a registered trademark of DuPont Performance Elastomers L.L.C.
Magnalube® is a registered trademark of Carleton-Stuart Corp.



II 2 GD c TX

Warning: The TX marking refers to the maximum surface temperature depending not on the equipment itself, but mainly on operating conditions. In this case, the maximum surface temperature depends upon the temperature of the process fluids.



This Page Intentionally Left Blank

This Page Intentionally Left Blank

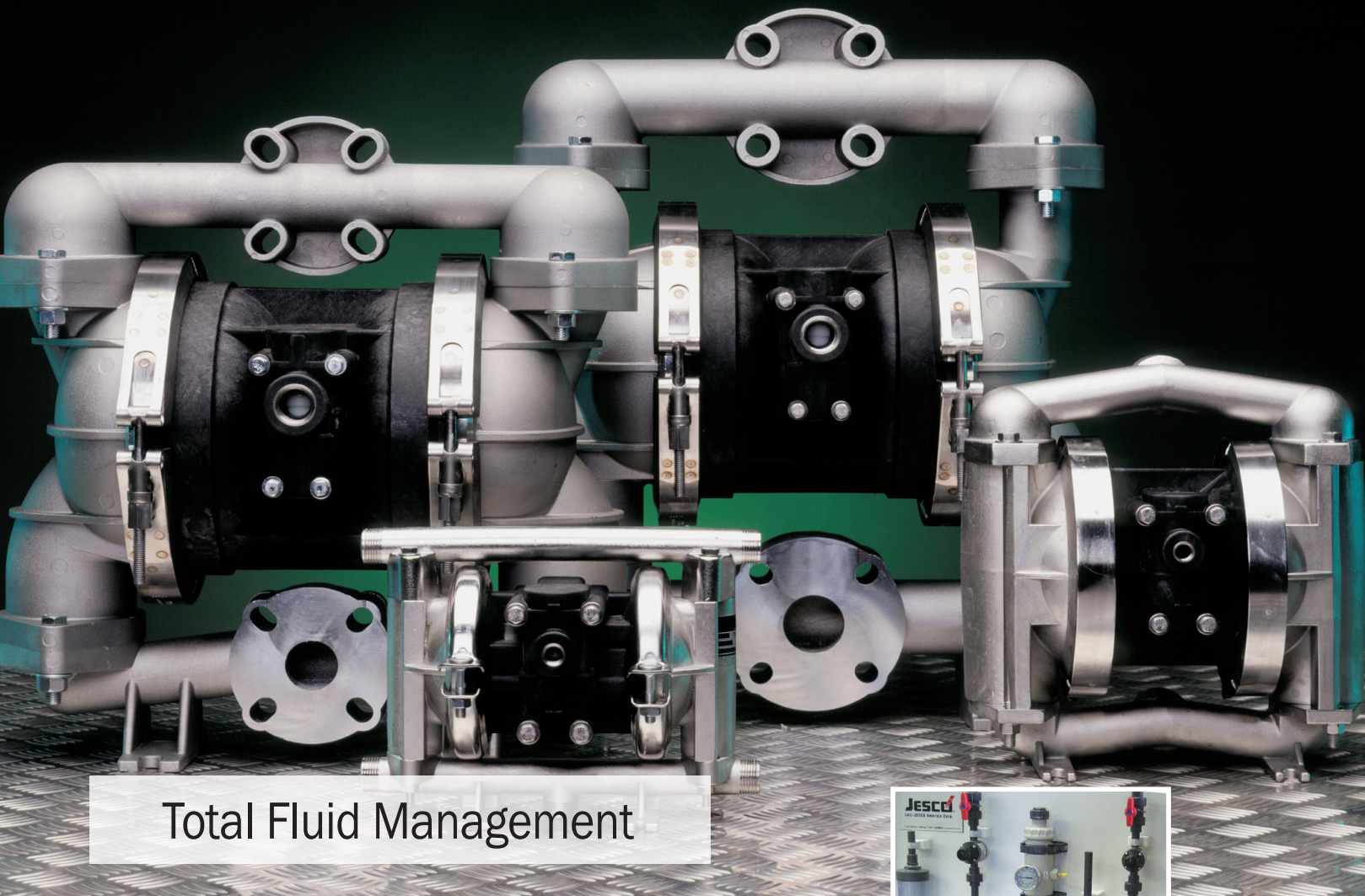

Total Fluid Management

Lutz-JESCO is your reliable partner for all of your chemical feed applications. From the single metering or transfer pump to the complete chemical feed system, we provide you with the appropriate Total Fluid Management solution.



Please contact us for more information!

Lutz-JESCO, Corp. · 55 Bermar Park · Rochester, NY 14624
Phone: (585) 426-0990 · Tollfree: (800) 554-2762 · Fax: (585) 426-4025
www.lutzjescoamerica.com
www.chemicalfeedsystems.com