

SELF-PRIMING CENTRIFUGAL PUMP
DS3 SERIES

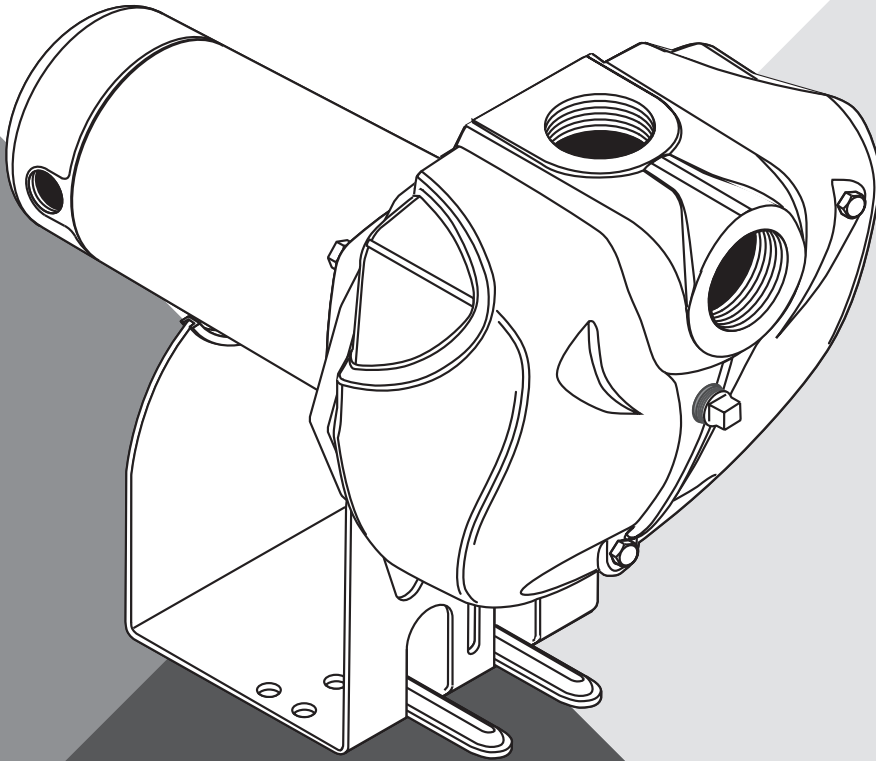

**INSTALLATION AND
OPERATION MANUAL**

pentair.com/sta-rite

TABLE OF CONTENTS

| SECTION..... | PAGE |
|-----------------------|-------------|
| Safety..... | 3 |
| Installation..... | 4-5 |
| Electrical..... | 6 |
| Operation..... | 7 |
| Maintenance..... | 8-10 |
| Troubleshooting..... | 11 |
| Parts List..... | 12 |
| Limited Warranty..... | 13 |

SAFETY

Carefully read and follow all safety instructions in this manual or on pump.

⚠ This is the safety alert symbol. When you see this symbol on your pump or in this manual, look for one of the following signal words and be alert to the potential for personal injury.

⚠ DANGER warns about hazards that will cause serious personal injury, death or major property damage if ignored.

⚠ WARNING warns about hazards that can cause serious personal injury, death or major property damage if ignored.

⚠ CAUTION warns about hazards that will or can cause minor personal injury or property damage if ignored.

The label **NOTICE** indicates special instructions which are important but not related to hazards.

Keep safety labels in good condition. Replace any missing or damaged ones.

California Proposition 65 Warning

⚠ WARNING This product and related accessories contain chemicals known to the State of California to cause cancer, birth defects or other reproductive harm.

ELECTRICAL SAFETY

⚠ Wire motor for correct voltage. See "Electrical" section of this manual and motor nameplate.

⚠ Ground motor before connecting to power supply.

⚠ Meet National Electrical Code, Canadian Electrical Code, and local codes for all wiring.

⚠ Follow wiring instructions in this manual when connecting motor to power lines.

| ⚠ WARNING | |
|---|--|
|  | Hazardous voltage. Can shock, burn, or cause death. Ground pump before connecting to power supply. |

GENERAL SAFETY

| ⚠ WARNING | |
|---|--|
|  | Hazardous pressure! Install pressure relief valve in discharge pipe. Release all pressure on system before working on any component. |

⚠ CAUTION Do not touch an operating motor. Modern motors can operate at high temperatures. To avoid burns when servicing pump, allow it to cool for 20 minutes after shut-down before handling.

Pump is designed as a lawn sprinkler only. To avoid heat built-up, over pressure hazard and possible injury, do not use in a pressure tank (domestic water) system. Do not use as a booster pump; pressurized suction may cause pump body to explode.

Do not allow the pump or piping to freeze. Freezing can cause equipment failure that leads to injury and voids warranty.

Pump water only with this pump.

Periodically inspect pump and system components.

Wear safety glasses at all times when working on pumps.

Keep work area clean, uncluttered and properly lighted; store properly all unused tools and equipment.

Keep visitors at a safe distance from the work areas.

Make workshops childproof; use padlocks and master switches; remove starter keys.

INSTALLATION

PRIOR TO PUMP INSTALLATION

Prior to pump installation, follow these steps to ensure proper installation and operations.

1. Well must not be more than 20' depth to water.
2. Be sure well is clear of sand. Sand will plug the pump and void the warranty.
3. Protect pump and all piping from freezing. Freezing will split pipe, damage pump and void the warranty. Check locally for frost protection requirements. Normally, pipe must 12" below frost line and pump must be insulated.
4. Be sure all pipes and the foot valve are clean and in good shape.
5. Ensure there are no air pockets or leaks in suction pipe. Use PTEE pipe thread sealant tape to seal pipe joints.
6. Unions installed near pump and well will aid in servicing but leave room for using wrenches.
7. **⚠ WARNING** Pump body may explode if used as a booster pump. DO NOT use in a booster application.

WELL PIPE INSTALLATION

Use the installation method below that matches your well type.

CASED WELL INSTALLATION

1. Inspect foot valve to be sure it works freely. Inspect strainer to be sure it is clean.
2. Connect foot valve and strainer to the first length of suction pipe and lower pipe into the well. Add sections of pipe as needed, using PTFE pip thread sealant tape on all male threads.
 - To prevent sand and sediment from entering the system, the foot valve/strainer should be at least 5 feet above the bottom of the well.
 - Additionally, the foot valve/strainer should be installed 10 to 20 feet below the lowest level to which water will drop while operating (pumping water level). Your well driller can furnish that information.
3. When the proper depth is reached, install a sanitary well seal over the pipe and in the well casing. Tighten the bolts to seal the casing.
4. Be sure the entire run of suction pipe is leakproof so pump does not lose prime and fail to work. Never install a suction pipe that is smaller than the suction port of the pump.
5. When using a foot valve, a priming tee and plug are recommended (Figure 1).

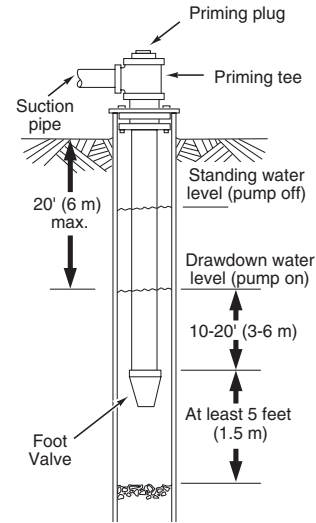

Figure 1: Cased/Dug Well Installation

DUG WELL INSTALLATION

Use the same procedures as Cased Well installation.

DRIVEN POINT INSTALLATION

1. Connect the suction pipe to the drive point (Figure 2). Keep horizontal pipe run as short as possible. Use PTFE pip thread sealant tape on male pipe threads. Multiple well points may be necessary to provide sufficient water to pump.
2. Install a check valve in horizontal piping (Figure 2). Ensure check valve flow arrow points toward the pump.
3. Never install a suction pipe that is smaller than the suction port of the pump.

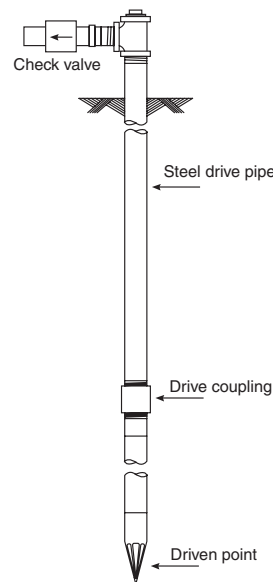

Figure 2: Driven Point Installation

INSTALLATION

DISCHARGE PIPE SIZES

1. If increasing discharge pipe size, install reducer in pump discharge port. Do not increase pipe size by stages.
2. When the pump is set away from the points of water use, the discharge pipe size should be increased to reduce pressure losses caused by friction.
 - Up to 100' run: Same size as pump discharge port.
 - 100' to 300' run: Increase one pipe size.
 - 300' to 600' run: Increase two pipe sizes.

LAWN SPRINKLING APPLICATION

This pump is designed for lawn sprinkling. It is designed to deliver plenty of water at full sprinkler pressure. It can pump from a pond, cistern or well points.

Pump discharge can be divided to supply two (2) or more sprinkler systems. A suggested multiple discharge to service is shown in Figure 3.

Do not use in a pressure tank or booster pump application.

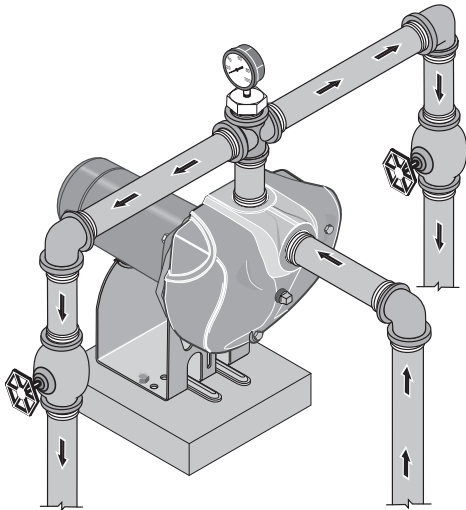

Figure 3: Multiple Discharge

PUMP INSTALLATION

1. Install pump as close to well head as possible. Long piping runs and many fittings create friction and reduce flow.
2. Bolt pump to solid, level foundation as shown in Figure 4.

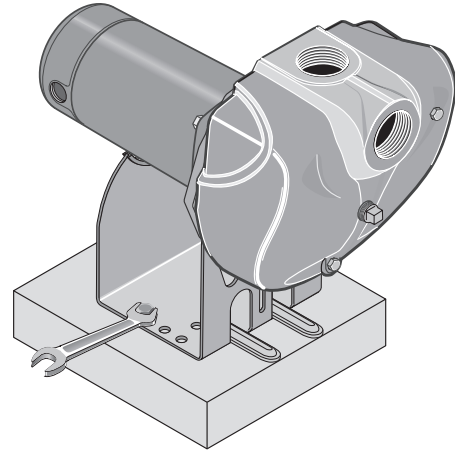

Figure 4: Bolt Pump Down

3. Support all piping connected to the pump (Figure 5).

NOTICE: For long horizontal pipe runs, install a priming tee between check valve and well head (Figure 1). For driven point installations, install a check valve (Figure 2). Be sure check valve flow arrow points **toward** pump.

Use schedule 80 or iron pipe. See "Well Pipe Installation" for more information.

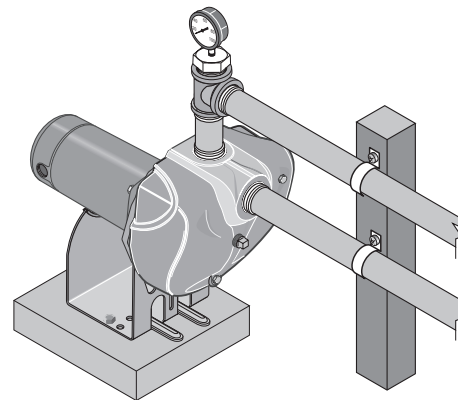

Figure 5: Independently Support All Piping Attached to Pump

4. Wrap 1-1/2 to two layers of PTFE pipe thread sealant tape clockwise (as you face end of pipe) on all male threads being attached to pump.

Ensure all suction pipe joints are air and water tight so the pump can pull water from the well.

5. Tighten joints hand tight plus 1-1/2 turns. Do not overtighten.

NOTICE: Install pump as close to well head as possible. Long piping runs and many fittings create friction and reduce flow.

ELECTRICAL

⚠ WARNING Hazardous voltage. Can shock, burn, or cause death. Disconnect power to motor before working on pump or motor.

⚠ WARNING Ground motor before connecting to electrical power supply. Failure to ground motor can cause severe or fatal electrical shock hazard. Do not ground to a gas supply line.

MOTOR VOLTAGE CONFIGURATION

⚠ WARNING Wire motor according to diagram on motor nameplate. If nameplate diagram differs from diagrams above, follow nameplate diagram.

The following instructions are intended for dual voltage (115 or 230 volts) single-phase motors. For 3-phase motors, or if your motor doesn't match any procedures in this section, follow the connection diagram on the your motor's nameplate.

VOLTAGE SETTINGS

Dual-voltage motors (motors that can operate at either 115 or 230 volts), are factory set to 230 volts. Do not change motor voltage setting if line voltage is 230 volts, or if you have a single voltage motor.

If you have a dual-voltage motor and will connect it to a 115 volt line, follow the procedures below.

1. Make sure power is off.
2. Remove the motor end cover via two screws to access the motor's terminal board for configuration.
3. The motor's voltage configuration will match one of the two styles shown in Figures 7 and 8.
4. If your motor's configuration matches the **plug type voltage selector** in Figure 7, pull the plug straight up.

Move the plug and attach at the 115 volt position. The plug will now cover 2 metal tabs and the plug arrow will point to 115V.

5. If your motor's configuration matches the **dial type voltage selector** in Figure 8, turn the dial counter-clockwise until 115 shows in the dial window.
6. For both voltage selector types, attach the power lead wires to the power lead terminals and secure.
7. Attach the ground wire to the green ground screw
8. Reinstall the motor end cover and screws.

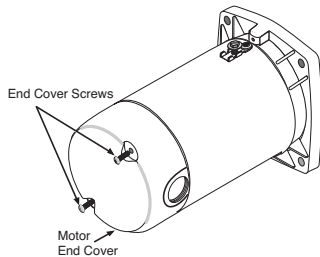

Figure 6: Removing Motor End Cover

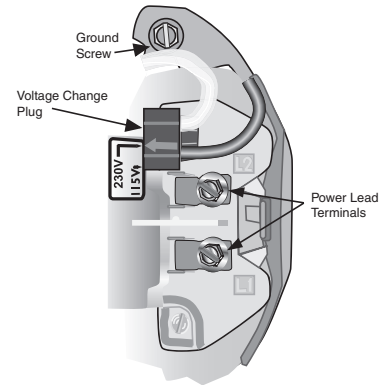

Figure 7: Voltage set to 230 volts, Plug Type

POWER SUPPLY CONNECTIONS

⚠ WARNING Supply voltage must be within $\pm 10\%$ of nameplate voltage. Incorrect voltage can cause fire or damage motor and voids warranty. If in doubt consult a licensed electrician.

⚠ WARNING Use wire size specified in Wiring Chart, Page 7. If possible, connect pump to a separate branch circuit with no other appliances on it.

⚠ WARNING Motor has automatic internal thermal overload protection. If motor has stopped for unknown reasons, thermal overload may restart it unexpectedly, which could cause injury or property damage. Disconnect power before servicing motor.

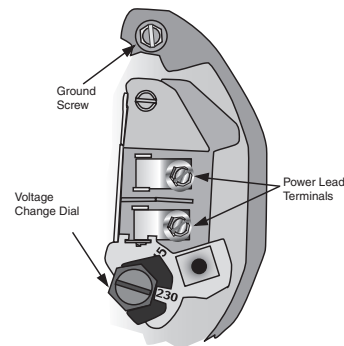

Figure 8: Voltage set to 230 volts, Dial Type

Install, ground, wire and maintain this pump in accordance with electrical code requirements. Consult your local building inspector for information about codes.

If this procedure or the wiring diagrams are confusing, consult a licensed electrician.

1. Provide a correctly fused disconnect switch for protection while working on motor. Consult local or national electrical codes for switch requirements.
2. Disconnect power before servicing motor or pump. If the disconnect switch is out of sight of pump, lock it open and tag it to prevent unexpected power application.

ELECTRICAL

3. Ground the pump permanently using a wire of the same size as that specified in this section's Wiring Chart. Make ground connection to green grounding terminal under motor canopy marked GRD. or ⏏ .
4. Connect ground wire to a grounded lead in the service panel or to a metal underground water pipe or well casing at least 10 feet long. Do not connect to plastic pipe or insulated fittings.
5. Protect current carrying and grounding conductors from cuts, grease, heat, oil, and chemicals.
6. Connect current carrying conductors to terminals L1 and L2 under motor canopy. When replacing motor, check wiring diagram on motor nameplate against Figure 7 and 8. If the motor wiring diagram does not match either diagram in Figure 7 and 8, follow the diagram on the motor.

Wiring Chart – Recommended Wire and Fuse Sizes

| MODEL | HP | MAX. LOAD AMP | VOLTS/HZ PHASE | BRANCH FUSE RATING AMP | DISTANCE IN FEET (METERS) FROM MOTOR SUPPLY | | | |
|----------------------------------|-------|---------------|----------------|------------------------|---|--------------|-------------|------------|
| | | | | | 0 - 50 | 51 - 100 | 101 - 200 | 201 - 300 |
| | | | | | (0 - 15) | (31 - 61) | (62 - 91) | (92 - 122) |
| AWG WIRE SIZE (mm ²) | | | | | | | | |
| DS3HE-01 | 1 | 14.8/7.4 | 115/230/60/1 | 20/15 | 12/14(3/2) | 12/14(3/2) | 8/14(8.4/2) | 6/14(14/2) |
| DS3HE3-01 | 1 | 3.6/1.8 | 230/460/60/3 | 20/15 | 14/14(2/2) | 14/14(2/2) | 14/14(2/2) | 14/14(2/2) |
| DS3HF-01 | 1-1/2 | 20/10 | 115/230/60/1 | 25/15 | 10/14(5.5/2) | 10/14(5.5/2) | 8/14(8.4/2) | 6/12(14/3) |
| DS3HF3-01 | 1-1/2 | 4.7/2.35 | 230/460/60/3 | 15/15 | 14/14(2/2) | 14/14(2/2) | 14/14(2/2) | 14/14(2/2) |
| DS3HG-01 | 2 | 24/12 | 115/230/60/1 | 30/15 | 12/14(3/2) | 10/14(5.5/2) | 6/14(14/2) | 6/12(14/3) |
| DS3HG3-01 | 2 | 5.8/2.9 | 230/460/60/3 | 15/15 | 14/14(2/2) | 14/14(2/2) | 14/14(2/2) | 14/14(2/2) |
| DS3HHG-01 | 2-1/2 | 24/12 | 115/230/60/1 | 30/15 | 12/14(3/2) | 10/14(5.5/2) | 6/14(14/2) | 6/12(14/3) |
| DS3HHG3-01 | 2-1/2 | 6.9/3.45 | 230/460/60/3 | 15/15 | 14/14(2/2) | 14/14(2/2) | 14/14(2/2) | 14/14(2/2) |

Order Online: www.PumpCatalog.com

OPERATIONS/MAINTENANCE

PRIMING THE PUMP

'Priming' refers to the pump expelling all air in the system and beginning to move water from its source out into the system. It does not refer only to pouring water into the pump (although pouring water in is usually the first step).

NEVER run pump dry. Running pump without adequate water will damage seals and can melt impeller and diffuser. To prevent damage, **fill pump with water before starting.**

1. Remove priming plug (Figure 9).

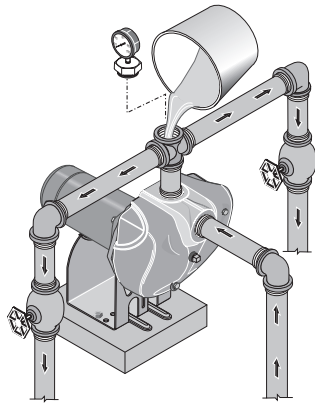

Figure 9: Remove Priming Plug and Fill Pump Before Starting

2. Make sure suction and discharge valves and any hoses on discharge side of pump are open.
3. Fill pump and suction pipe with water.

NOTICE: If a priming tee and plug have been provided for a long horizontal run, be sure to fill suction pipe through this tee and replace plug. (Do not forget to PTFE pipe thread sealant tape the plug.)
4. Replace priming plug, using PTFE pipe thread sealant tape on thread, and tighten plug.
5. Start pump. Water should be produced within 10 minutes, depending on depth of water (not more than 20') and length of horizontal run (10' of horizontal suction pipe = 1' of vertical lift due to friction losses in the pipe).

If no water is produced within 10 minutes:

- Stop pump
- Release all pressure
- Remove priming plug
- Refill and try again.

⚠ WARNING Hazardous pressure and risk of explosion and scalding. If pump is run continuously at no flow (that is, with discharge shut off or without priming), water may boil in pump and piping system. Under steam pressure, pipes may rupture, blow off of fittings or blow out of pump ports and scald anyone near.

To prevent explosion, do the following:

- A. Be sure discharge (valve, pistol grip hose nozzle, etc.) is open whenever pump is running.

- B. When priming, monitor pump and piping temperature. If pump or piping begin to feel warm to the touch, shut off pump and allow system to cool off. Release all pressure in system and refill pump and piping with cold water.
- C. If pump fails to produce water when attempting to prime, release all pressure, drain pump and refill with cold water after every two attempts.

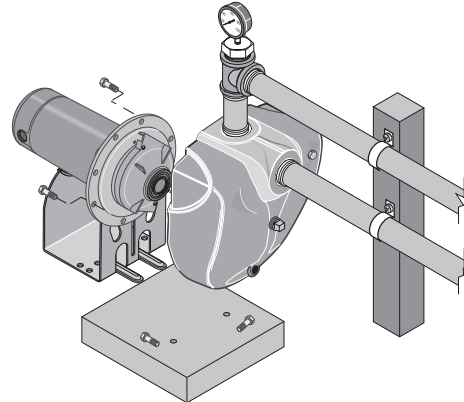

Figure 10: Slide Motor

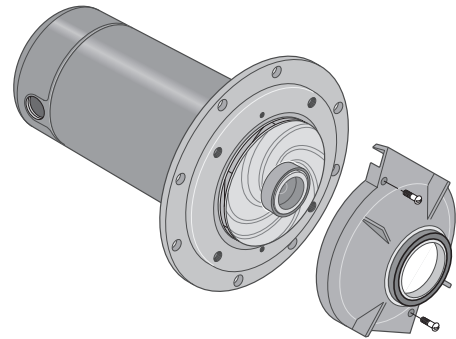

Figure 11: Remove Diffuser

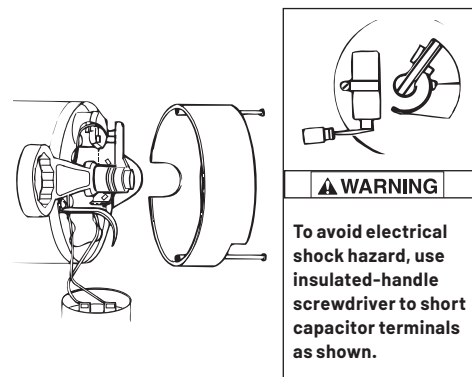

Figure 12: Hold Shaft

MAINTENANCE

MAINTENANCE

Pump and piping need not be disconnected to repair or replace motor or seal (Figure 10). If motor is replaced, replace the shaft seal (see Parts List). Keep one on hand for future use.

Be sure to prime pump before starting.

Check motor label for lubrication instructions. The mechanical shaft seal in the pump is water lubricated and self-adjusting.

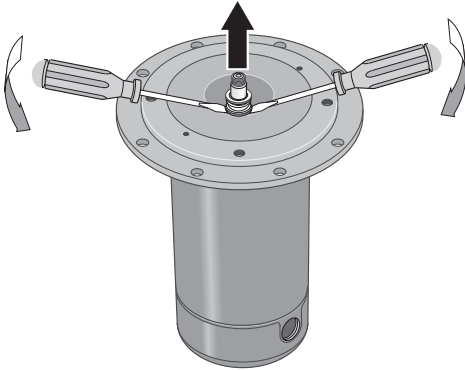

Figure 13: Remove Seal plate

CLEANING/REPLACING IMPELLER

1. Disconnect power to motor. Mark wires for correct reassembly.
2. Drain pump when disconnecting from service or when it might freeze.
3. Remove the cap screws holding the seal plate to the pump body. Pull the motor assembly and seal plate away from the pump body (Figure 10) and CAREFULLY remove gasket.
4. Remove screws that fasten diffuser to the seal plate and remove diffuser (Figure 11). The exposed impeller can now be cleaned.
5. If the impeller must be replaced, loosen the two machine screws and remove motor canopy (Figure 12).

⚠ WARNING Capacitor voltage may be hazardous. To discharge capacitor, hold insulated handle screwdriver **BY THE HANDLE** and short capacitor terminals together (Figure 12). Do not touch metal screwdriver blade or capacitor terminals. If in doubt, consult a qualified electrician.

4. Unscrew capacitor clamp and remove capacitor. Do not disconnect capacitor wires to motor.
5. Slide 7/16" open end wrench behind spring-loaded switch on motor end of shaft. Hold motor shaft with wrench on shaft flats and unscrew impeller screw (if used) by turning clockwise (left hand thread) when looking into eye of impeller.
6. To reinstall, reverse steps 1 through 7.
7. To complete, see steps under the "Pump Reassembly" section.

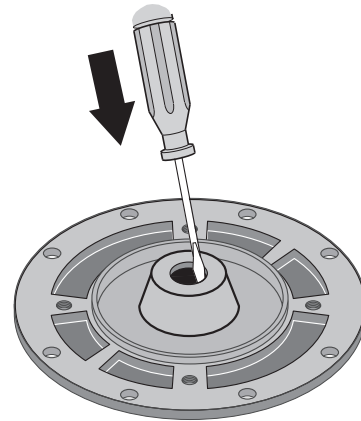

Figure 14: Tap Out Seal

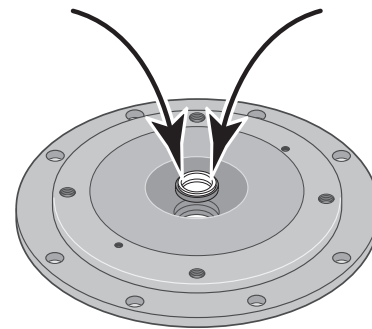

Figure 15: Press in New Seal

REMOVING OLD SEAL

1. Follow steps 1 through 6 under "Cleaning/Replacing Impeller."
2. Remove rotating half of seal by placing two screwdrivers under seal ring and **carefully** prying up (Figure 13).
3. Remove nuts from studs holding seal plate to motor. Carefully slide seal plate off of shaft.

NOTICE: Be sure you do not scratch or mar shaft. If shaft is marred, it must be dressed smooth with fine emery or crocus cloth before installing new seal. **DO NOT** reduce shaft diameter!

4. Place the seal plate face down on a flat surface and tap out the stationary half of the seal (Figure 14).

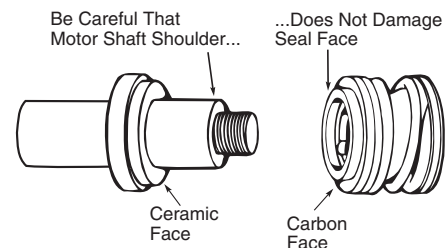

Figure 16: Protect Seal Faces

MAINTENANCE

INSTALLING NEW SEAL

Gaskets and o-rings are not interchangeable per models. Make sure to install the type of gasket or o-ring you removed.

1. Clean seal cavity in seal plate.
2. Sparingly wet outer edge of rubber cup on ceramic seat with liquid soap.
3. Put clean cardboard washer on seal face. The ceramic seal's polished face should be facing up. Firmly and squarely, press ceramic seal into cavity using only hand pressure (Figure 15).
4. If seal will not seat correctly:
 - Remove seal, placing polished side up on bench. Re-clean cavity and install as outlined in previous step.
 - If seal still does not seat properly after re-cleaning cavity, place a cardboard washer over polished seal face and carefully press into place using a piece of standard 3/4 inch pipe as a press being careful not to scratch seal face.
5. Dispose of cardboard washer and recheck seal face to be sure it is free of dirt, foreign particles, scratches and grease.
6. Inspect shaft to be sure it is free of nicks and scratches.
7. Reassemble pump body half to motor flange. **BE SURE** it is right side up.
8. Apply liquid soap sparingly (one drop is sufficient) to inside diameter of rotating seal member.
9. Slide rotating seal member (carbon face first) onto shaft until rubber drive ring hits shaft shoulder.

DO NOT nick or scratch carbon face of seal when passing it over threaded shaft end or shaft shoulder. The carbon surface must remain clean or short seal life will result (Figure 16).

10. Hold motor shaft with 7/16" open end wrench on shaft flats and screw impeller onto shaft. **Be sure you do not touch capacitor terminals with body or any metal object.** Tightening impeller will automatically locate seal in correct position (Figure 12).
11. Replace impeller screw (if used) by turning counterclockwise (left-hand thread) into end of shaft.
12. Remount diffuser on seal plate with two screws.
13. Follow instructions under "Pump Reassembly."

PUMP REASSEMBLY

1. Clean gasket surfaces on pump body and seal plate. Install new gasket.
2. Slide motor/seal plate assembly into pump body. Secure with capscrews.
3. Replace base mounting bolts.
4. Replace motor wiring and close draincock.
5. Follow priming procedure in the "Priming The Pump" section of this manual.
6. Check for leaks.

TROUBLESHOOTING

| SYMPTOM | POSSIBLE CAUSE(S) | CORRECTIVE ACTION |
|--|---|--|
| Motor will not run | Disconnect switch is off | Be sure switch is on |
| | Fuse is blown | Replace fuse |
| | Starting switch is defective | Replace starting switch |
| | Wires at motor are loose, disconnected, or wired incorrectly | Refer to instructions on wiring. Check and tighten all wiring. ⚠ WARNING Capacitor voltage may be hazardous. To discharge capacitor, hold insulated handle screwdriver BY THE HANDLE and short capacitor terminals together. Do not touch metal screwdriver blade or capacitor terminals. If in doubt, consult a qualified electrician. |
| Motor runs hot and overload kicks off | Motor is wired incorrectly | Refer to wiring instructions |
| | Voltage is too low | Check with power company. Install heavier wiring if wire size is too small (See Electrical section of this manual) |
| Motor runs but no water is delivered NOTICE: Check prime before looking for other causes. Unscrew priming plug and see if there is water in priming hole | Pump in new installation did not pick up prime through: 1. Improper priming 2. Air leaks 3. Leaking foot valve | In new installation: 1. Re-prime according to instructions 2. Check all connections on suction line 3. Replace foot valve |
| | Pump has lost prime through: 1. Air leaks 2. Water level below suction of pump | In installation already in use: 1. Check all connections on suction line and shaft seal 2. Lower suction line into water and re-prime. If receding water level in well exceeds suction lift, a deep well pump is needed |
| | Impeller is plugged | Clean impeller as per Cleaning/replacing Impeller procedures. |
| | Check valve or foot valve is stuck in closed position | Replace check valve or foot valve |
| | Pipes are frozen | Thaw pipes. Bury pipes below frost line. Heat pit or pump house |
| | Foot valve and/or strainer are buried in sand or mud | Raise foot valve and/or strainer above well bottom |
| | Pump does not deliver water to full capacity | Leaking foot valve is causing lose of priming |
| Water level in well is greater than 25 feet below suction of pump | | A deep well jet pump may be needed |
| Steel piping (if used) is corroded or limed, causing excess friction | | Replace with plastic pipe where possible, otherwise with new steel pipe |
| Offset piping is too small in size | | Use larger offset piping |

PARTS LIST

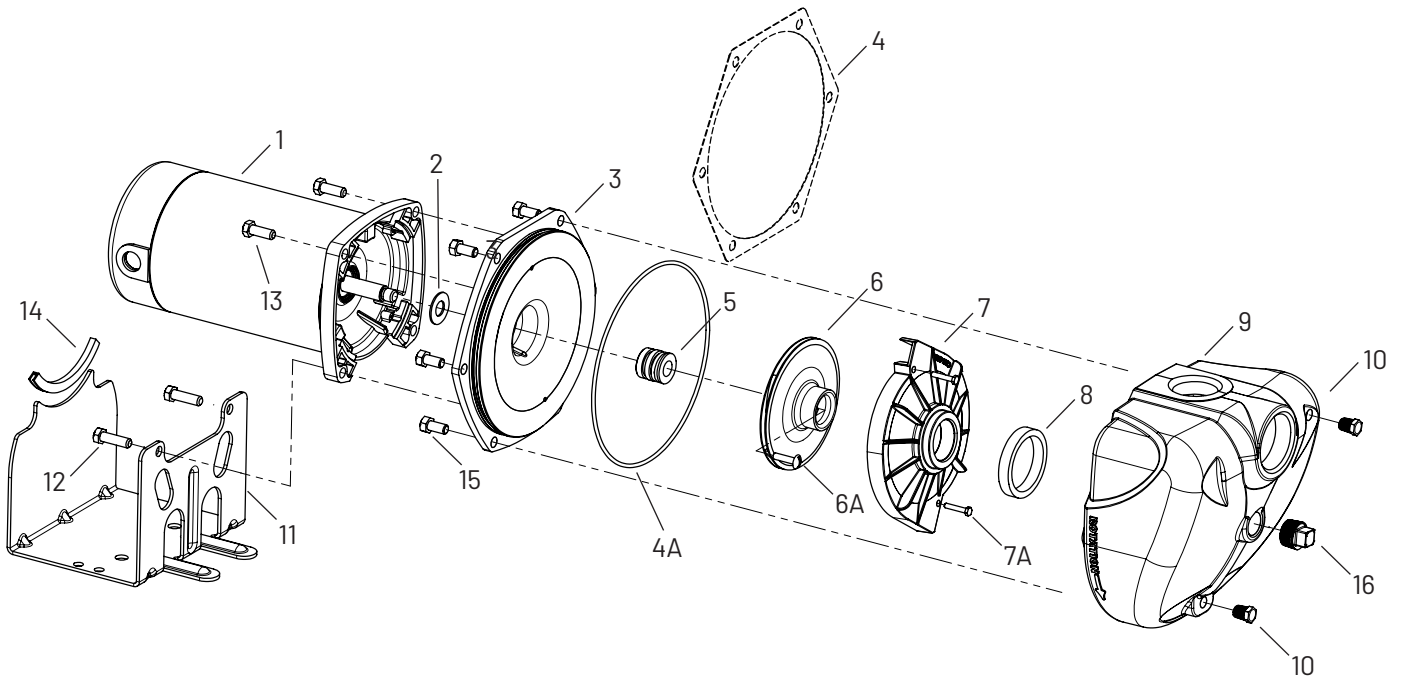

| Key No. | Part Description | Qty. | Model Number | | | |
|---------|------------------------------|------|-------------------------------|-----------------------------------|-------------------------------|-------------------------------------|
| | | | DS3HE-01 DS3HE3-01 1 HP | DS3HF-01 DS3HF3-01 1-1/2 HP | DS3HG-01 DS3HG3-01 2 HP | DS3HHG-01 DS3HHG3-01 2-1/2 HP |
| 1 | Motor, 115/230V, 1 Phase | 1 | J218-596PKG | J218-601PKG | J218-883APKG | J218-628A |
| 1 | Motor, 230/460V, 3 Phase | 1 | AP100EL | AP100FL | AP100GL | AP100G5L |
| 2 | Water Slinger | 1 | 17351-000 | 17351-0009 | 17351-0009 | 17351-0009 |
| 3 | Seal Plate | 1 | C3-155-SR | C3-155-SR | C3-117 | C3-117 |
| 4 | Gasket - Seal Plate | 1 | C20-86N | C20-86N | C20-87N | C20-87N |
| 4A | O-Ring | 1 | 25276 | — | 34516 | — |
| 5 | Shaft Seal | 1 | U109-6B | U109-6B | U109-6B | U109-6B |
| 6 | Impeller (1 Phase) | 1 | C105-92PKB | C105-92PC | C105-214PDA | C105-214PA |
| 6 | Impeller (3 Phase) | 1 | C105-92PKBA | C105-92PCA | C105-214PDA | C105-214PA |
| 6A | Impeller Screw (1 Phase) | 1 | — | — | C30-14SS | C30-14SS |
| 6A | Impeller Screw (3 Phase) | 1 | C30-14SS | C30-14SS | C30-14SS | C30-14SS |
| 7 | Diffuser | 1 | C101-276P | C101-276P | C101-182 | C101-182 |
| 7A | Screw 10-24 x1" Lg Hex Head | 2 | U30-696SS | U30-696SS | — | — |
| 7A | Machine screw 8-32x7/8" Lg. | 2 | — | — | U30-53SS | U30-53SS |
| 8 | Diffuser Ring | 1 | C21-10 | C21-10 | C21-2 | C21-2 |
| 9 | Pump Body Assembly | 1 | C76-67E | C76-67E | C76-68E | C76-68E |
| 10 | Plug 1/4" NPT Hex Head | 2 | U78-941ZPV | U78-941ZPV | U78-941ZPV | U78-941ZPV |
| 11 | Base | 1 | C4-82 | C4-82 | C4-82 | C4-82A* |
| 12 | 3/8-16x1-1/4" Lower Capscrew | 1 | U30-75ZP | U30-75ZP | U30-75ZP | U30-75ZP |
| 13 | 3/8-16x1" Upper Capscrew | 1 | U30-74ZP | U30-74ZP | U30-74ZP | U30-99SS |
| 14 | Motor Pad | 1 | C35-5 | C35-5 | C35-5 | C35-5 |
| 15 | Capscrew 3/8-16x3/4" Lg | 6 | U30-72ZP | U30-72ZP | — | — |
| 15 | Capscrew 5/16-18x3/4" Lg. | 8 | — | — | U30-60ZP | U30-60ZP |
| 16 | Pipe Plug 3/4" NPT - Sq. Hd. | 1 | U78-60ZPS | U78-60ZPS | U78-60ZPS | U78-60ZPS |
| • | Lockwasher 3/8" | 2 | U43-12ZP | U43-12ZP | U43-12ZP | U43-12ZP |
| • | Nut, 3/16"-18 Hex Head | 2 | U36-37ZP | U36-37ZP | U36-37ZP | U36-37ZP |

• Not illustrated.
* Model DS3HHG3-01 uses Base C4-82.

LIMITED WARRANTY

Pentair STA-RITE® warrants to the original consumer purchaser (“Purchaser” or “You”) of the products listed below, that they will be free from defects in material and workmanship for the Warranty Period shown below.

| Product | Warranty Period |
|--|---|
| Water Systems Products – jet pumps, small centrifugal pumps, submersible pumps and related accessories | whichever occurs first: 12 months from date of original installation, or 18 months from date of manufacture |
| Pro-Source® Composite Tanks | 5 years from date of original installation |
| Pro-Source Steel Pressure Tanks | 5 years from date of original installation |
| Pro-Source Epoxy-Lined Tanks | 3 years from date of original installation |
| Sump/Sewage/Effluent Products | 12 months from date of original installation, or 18 months from date of manufacture |

Our warranty will not apply to any product that, in our sole judgement, has been subject to negligence, misapplication, improper installation, or improper maintenance. Without limiting the foregoing, operating a three phase motor with single phase power through a phase converter will void the warranty. Note also that three phase motors must be protected by three-leg, ambient compensated, extra-quick trip overload relays of the recommended size or the warranty is void.

Your only remedy, and Pentair STA-RITE's only duty, is that STA-RITE repair or replace defective products (at STA-RITE's choice). You must pay all labor and shipping charges associated with this warranty and must request warranty service through the installing dealer as soon as a problem is discovered. No request for service will be accepted if received after the Warranty Period has expired. This warranty is not transferable.

PENTAIR STA-RITE SHALL NOT BE LIABLE FOR ANY CONSEQUENTIAL, INCIDENTAL, OR CONTINGENT DAMAGES WHATSOEVER.

THE FOREGOING WARRANTIES ARE EXCLUSIVE AND IN LIEU OF ALL OTHER EXPRESS AND IMPLIED WARRANTIES, INCLUDING BUT NOT LIMITED TO THE IMPLIED WARRANTIES OF MERCHANTABILITY AND FITNESS FOR A PARTICULAR PURPOSE. THE FOREGOING WARRANTIES SHALL NOT EXTEND BEYOND THE DURATION EXPRESSLY PROVIDED HEREIN.

Some states do not allow the exclusion or limitation of incidental or consequential damages or limitations on the duration of an implied warranty, so the above limitations or exclusions may not apply to You. This warranty gives You specific legal rights and You may also have other rights which vary from state to state.

This Limited Warranty is effective November 18, 2019 and replaces all undated warranties and warranties dated before November 18, 2019.



Order Online: www.PumpCatalog.com

293 Wright Street | Delavan, WI 53115 | Ph: 888.782.7483 | Fax: 800.426.9446 | pentair.com

For a detailed list of where Pentair trademarks are registered, please visit www.pentair.com/en/registrations.html. Pentair trademarks and logos are owned by Pentair PLC, or its affiliates. Third party registered and unregistered trademarks and logos are the property of their respective owners. Because we are continuously improving our products and services, Pentair reserves the right to change specifications without prior notice. Pentair is an equal opportunity employer.

S536 (11-25-19) ©2019 Pentair. All Rights Reserved.