

Air Operated Double Diaphragm Pump

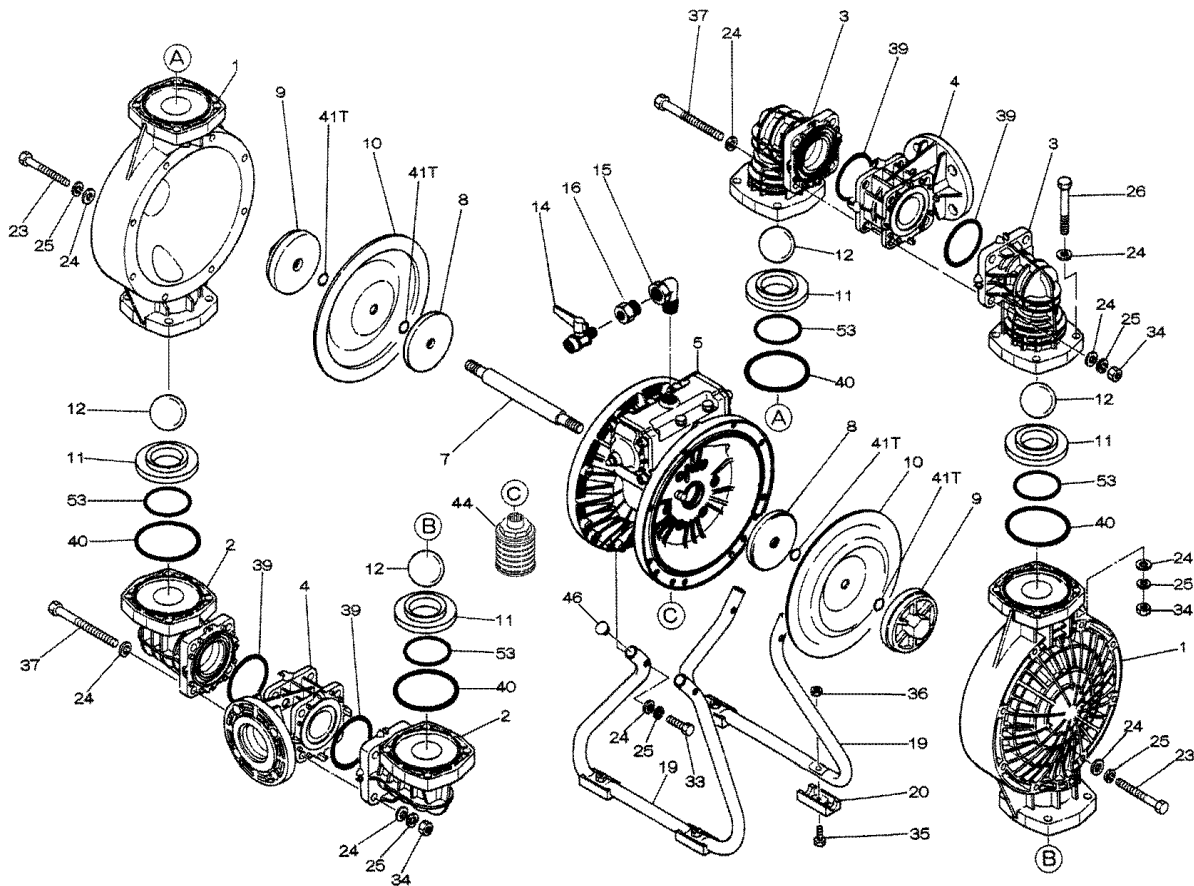

Air Operated Double Diaphragm Pump

■Body Assembly

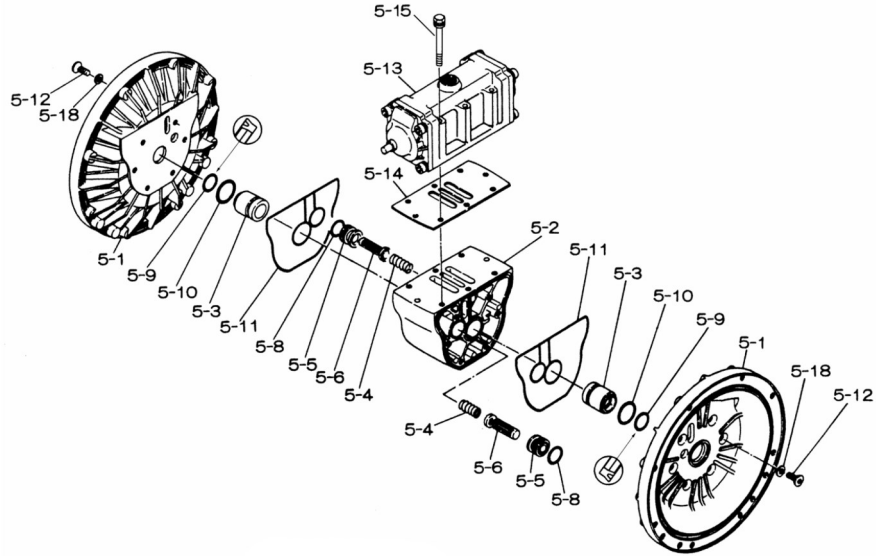

■Valve Body Assembly

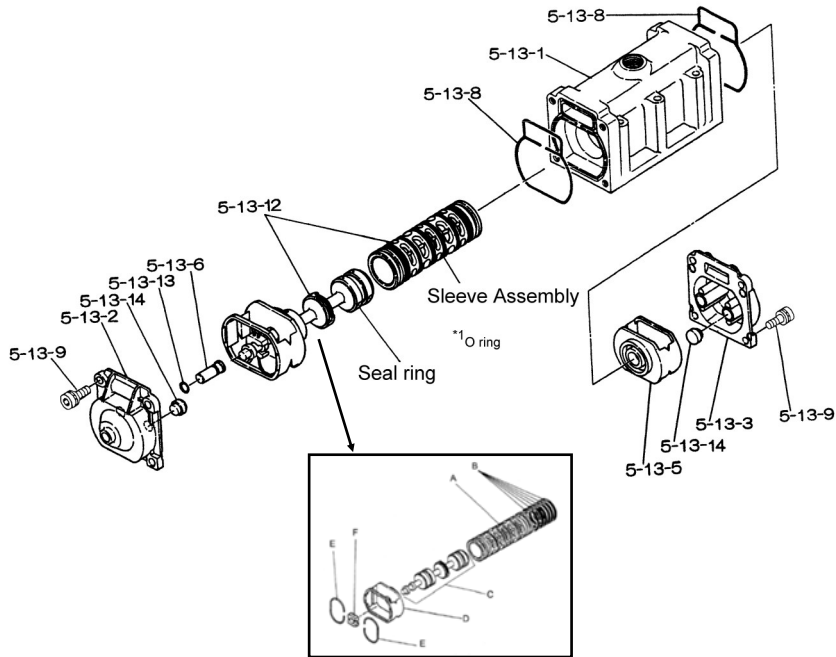

Air Operated Double Diaphragm Pump

REF. NO.	PART NO.	DESCRIPTION	QTY.	REORDER
1	780257	OUT CHAMBER 40PVDF	2	
2	780251	IN MANIFOLD 40PVDF	2	
3	780258	OUT MANIFOLD 40PVDF	2	
4	780216	CENTER MANIFOLD 40PVDF	2	
5	803111	CENTER BODY ASSY	1	
5- 1	711933	AIR CHAMBER 40	2	
5- 2	711936	BODY	1	
5- 3	780325	THROAT BEARING	2	
5- 4	711937	PILOT VALVE SPRING	2	
5- 5	771740	PILOT VALVE SEAT	2	
5- 6	832162	PILOT VALVE ASSY	2	
5- 8	640020	O-RING	2	
5- 9	685444	V-PACKING	2	
5-10	640029	O-RING	2	
5-11	771742	GASKET	2	
5-12	683812	FLAT SOCKET	12	
5-13	802971	VALVE BODY ASSY	1	
5-13- 1	711931	VALVE BODY 40/50/80	1	
5-13- 2	580999	CAP A	1	
5-13- 3	581000	CAP B	1	
5-13- 5	771735	SPRING RETAINER	1	
5-13- 6	712976	RESET BUTTON	1	
5-13- 8	771738	GASKET	2	
5-13- 9	685036	SOCKET BOLT	8	
5-13-12	805084	C SPOOL ASSY 40/50/80	1	
A	803675	SLEEVE ASSY.	1	
B	640036	O-RING	6	
C	805085	SPOOL ASSY.	1	
D	771735	SPRING RETAINER	1	
E	711932	C-SPRING	2	
F	771734	BLOCK	1	
5-13-13	640005	O-RING	1	
5-13-14	684128	CUSHION 40/50/80 CAP	4	
5-14	771712	GASKET	1	
5-15	684240	BOLT	6	
5-18	684987	WASHER 40/50/80	12	
7T	711939	CENTER ROD 40/50T	1	
8T	707817	CENTER DISK 40T (AIR SIDE)	2	
9T	780207	CENTER DISK 40 (LIQUID SIDE)	2	
10	770814	DIAPHRAGM	2	
11	772739	VALVE SEAT (PTFE) 40	4	
12	770692	BALL 40T	4	
14	686972	BALL VALVE 1/2	1	
15	682523	ELBOW	1	
16	684339	BUSHING 40	1	
19	711925	STAND 40PP	2	
20	771865	FOOT RUBBER 40/50/80 P	4	
23	686156	BOLT	16	
24	631330	WASHER FLAT M10 SS	68	
25	680257	SPRING WASHER M10 SS D	44	
26	686162	BOLT	16	
33	621179	BOLT	4	
34	628013	NUT M10X1.5 CT SS	24	
35	621149	BOLT	4	
36	683837	NUT W/ FLANGE	4	
37	683542	BOLT	8	
39	643060	O-RING	4	
40	643064	O-RING	4	
41T	643015	O-RING	4	
44	804764	SILENCER ASSY	1	
46	683641	CAP 40/50/80PP STAND	4	
53	643136	O-RING	4	
KIT	K40-VT	LIQUID END KIT		
KIT	K45-AM	AIR MOTOR KIT		

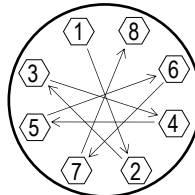

Tightening torque for center rod and out chambers.

Center Rod 36 ft-lbf {50 N-m}
Out Chambers 26 ft-lbf {35 N-m}

Tightening torque for manifold bolts.

BVT 15 ft-lbf {20 N-m}

General Tools:

- Socket wrenches - 13mm, 17mm
- Hexagonal box wrench - 5mm
- Small crowbars - 2
- Open-end wrenches - 17mm

Special Tools (sold separately):

- Wrench (771868) used to remove the center disk.
- Sleeve remover (713180) used to remove sleeves.

Miscellaneous:

- Assembly Oil - turbine oil none additional class 1 (equivalent to ISO VGA32 grade)
- Nuts - M16 x 1.5
- Thread locker
- Urea grease grade (NLGI) No. 2

Customer Notes

Model #: _____
 Description: _____
 Serial #: _____
 Date Installed: _____
 Department Location: _____
 Tag/Project: _____