

# EXPLODED VIEW & PARTS LISTING

## Air Operated Double Diaphragm Pump

Model: DP-40BST-HD (XDP)

Part#: 854360 (FLG)

Part#: 854367 (NPT)



Trial Program

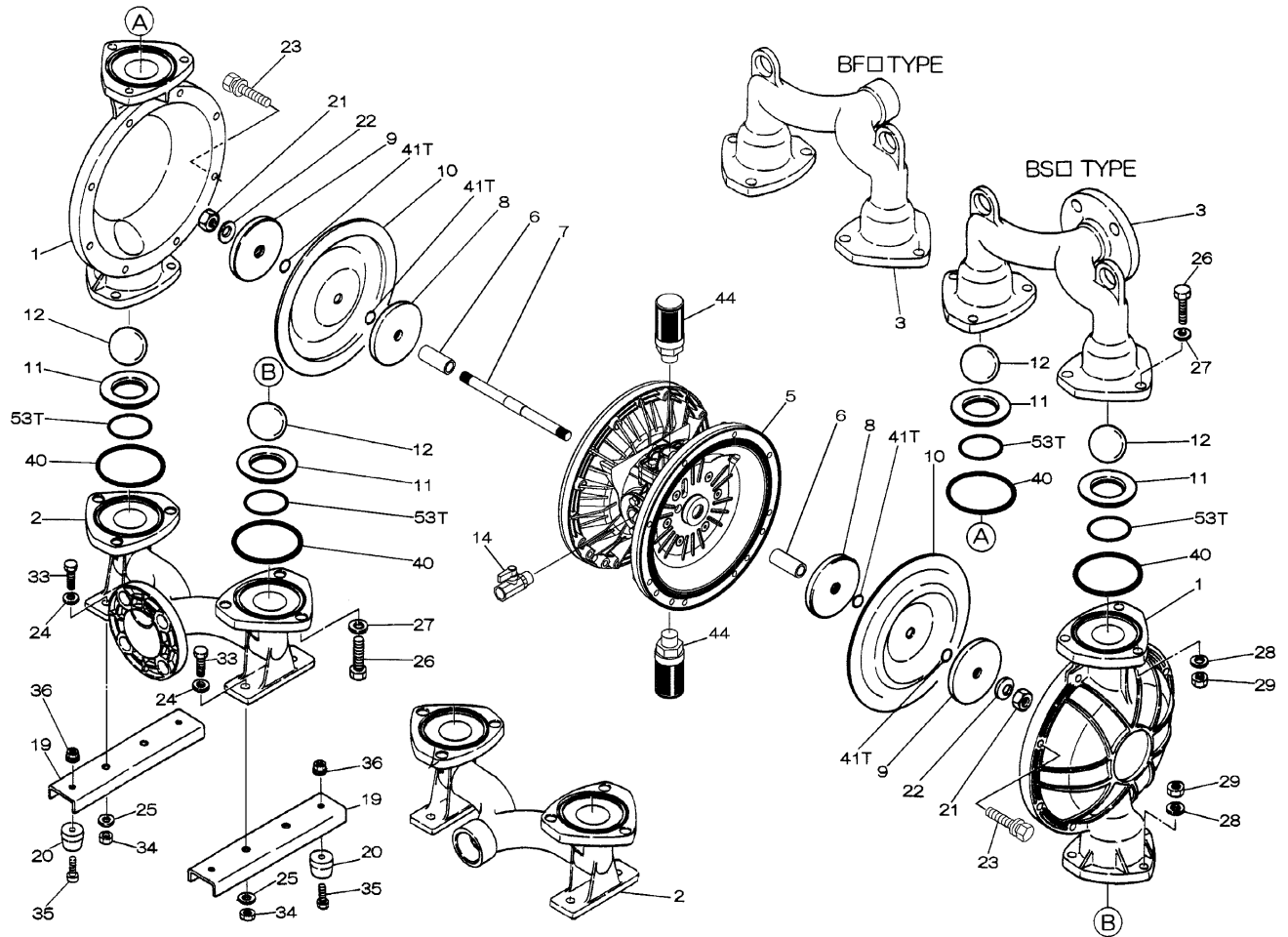

**804850 Center Body Assembly**

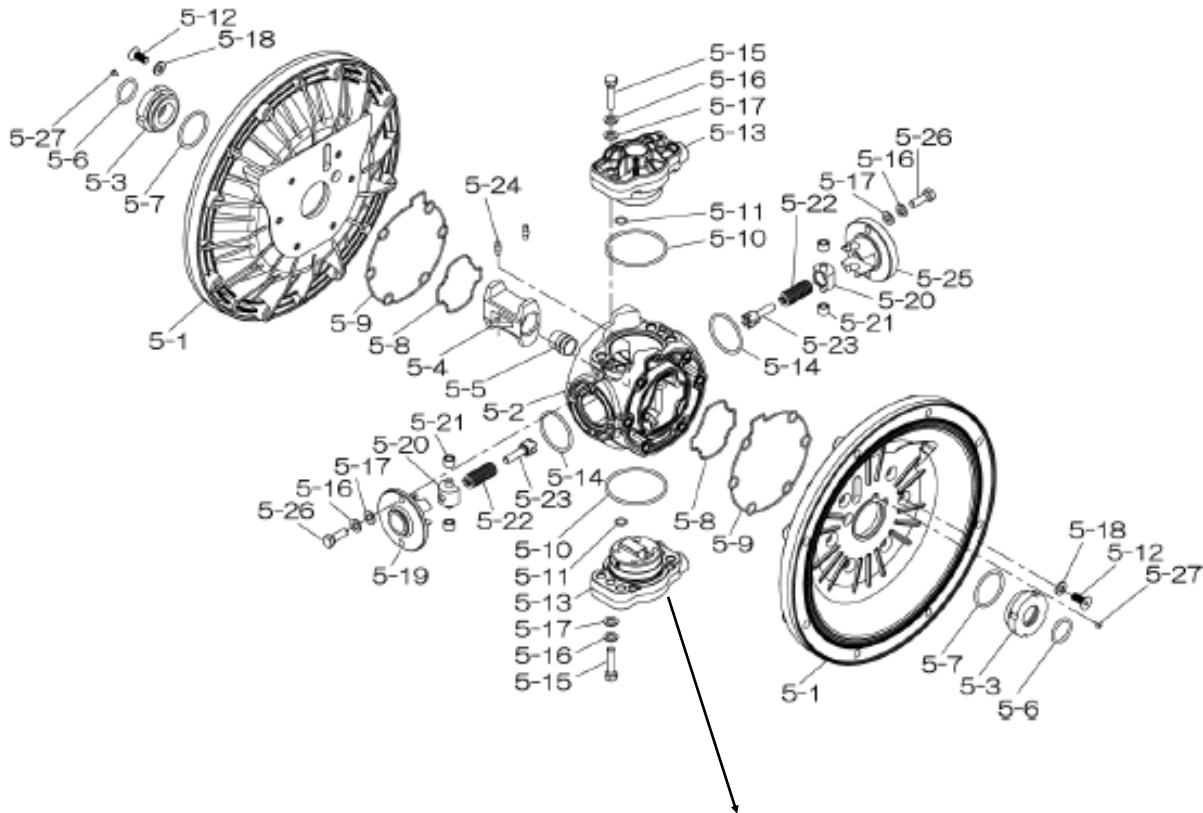

**804784 Valve Body Assembly**

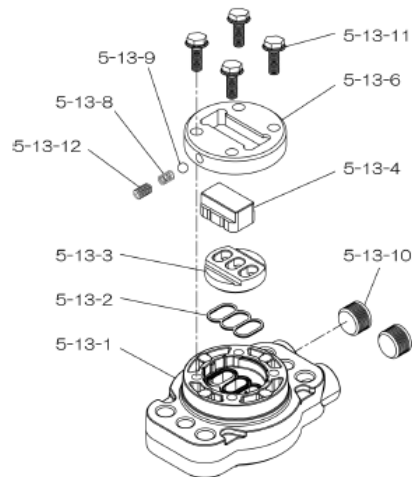

REF. No.	PARTS No.	DESCRIPTION	QTY.	REORDER
1	712931	OUT CHAMBER 40SS	2	
2	712599	IN MANIFOLD 40SS FLG	1	
2	712601	IN MANIFOLD 40SS NPT	1	
3	712598	OUT MANIFOLD 40SS FLG	1	
3	712600	OUT MANIFOLD 40SS NPT	1	
5	804850	CENTER BODY ASSY DP-40T-HD	1	
<b>5- 1</b>	<b>716215</b>	<b>AIR CHAMBER</b>	<b>2</b>	
5- 2	716256	BODY	1	
<b>5- 3</b>	<b>773095</b>	<b>THROAT BEARING</b>	<b>2</b>	
5- 4	716214	SHUTTLE (CS)	1	
<b>5- 5</b>	<b>773047</b>	<b>CENTER ROD GUIDE</b>	<b>1</b>	
<b>5- 6</b>	<b>640023</b>	<b>O RING 24.6MM X 3.6MM</b>	<b>2</b>	
<b>5- 7</b>	<b>640133</b>	<b>O RING</b>	<b>2</b>	
<b>5- 8</b>	<b>773040</b>	<b>GASKET</b>	<b>2</b>	
<b>5- 9</b>	<b>773041</b>	<b>GASKET</b>	<b>2</b>	
<b>5-10</b>	<b>640138</b>	<b>O RING (64.5X3.0MM)</b>	<b>2</b>	
<b>5-11</b>	<b>640007</b>	<b>O RING 9.5MM X 2.0MM</b>	<b>8</b>	
5-12	683812	M8X1.25X20 FLAT SOCKET	12	
5-13	804784	VALVE BODY ASSY	2	
<b>5-13- 1</b>	<b>716244</b>	<b>VALVE BODY(H40.50.80)</b>	<b>1</b>	
<b>5-13- 2</b>	<b>773042</b>	<b>GASKET</b>	<b>1</b>	
5-13- 3	716246	SEAT (CS)	1	
5-13- 4	773425	BLOCK	1	
5-13- 6	773426	GUIDE PLATE	1	
5-13- 8	706612	SPRING INK	1	
5-13- 9	686271	BALL	1	
5-13-10	772934	PLUG 20/25-PP	2	
5-13-11	602300	TAPPING BOLT M6X1X16	4	
5-13-12	610025	HEX. SOCKET HEAD SCREW	1	
<b>5-14</b>	<b>640134</b>	<b>O RING 44.5MM X 3MM</b>	<b>2</b>	
5-15	611153	BOLT M8X1.25X35 HEX FT	4	
5-16	631420	SPRING WASHER M8 ZINC	8	
5-17	631013	WASHER FLAT M8 ZINC DI	8	
5-18	684987	WASHER 40/50/80 NEW	12	
5-19	716249	RETAINER	1	
5-20	713620	SPRING GUIDE	2	
<b>5-21</b>	<b>773067</b>	<b>BUSH</b>	<b>4</b>	
<b>5-22</b>	<b>686303</b>	<b>SPRING</b>	<b>2</b>	
5-23	714446	TRIP ARM	2	
<b>5-24</b>	<b>700231</b>	<b>PIN</b>	<b>2</b>	
5-25	716216	RETAINER	1	
5-26	611149	BOLT M8X1.25X25 FT ZIN	4	
5-27	686337	TAPPING SCREW	2	
6	716399	CENTER BUSH(H4050)	2	

REF. No.	PARTS No.	DESCRIPTION	QTY.	REORDER
7	716404	CENTER ROD(H4050)	1	
8	707817	CENTER DISK 40T INNER	2	
9	707818	CENTER DISK 40SS-T	2	
10	770814	DIAPHRAGM (PTFE) 40	2	
11	711908	VALVE SEAT 40SS	4	
12	770692	BALL 40T -50MM PTFE	4	
14	684321	BALL VALVE 40&38F 1/2	1	
16	634601	BUSHING 40	1	
19	711911	BASE 40	2	
20	771402	FOOT RUBBER 40/50/80&2	4	
21	706128	NUT M16X1.50 SS	2	
22	682740	WASHER M16 SS CONICAL	2	
23	686162	BOLT	16	
24	631014	WASHER FLAT M10 ZINC	4	
25	631917	WAVE WASHER M10	20	
26	611203	BOLT M12X1.75X50 ZINC	12	
27	631015	WASHER FLAT M12 ZINC D	12	
28	631918	WAVE WASHER	12	
29	627014	NUT M12X1.75 CT ZINC	12	
33	611175	BOLT M10 X 30 FT ZY	4	
34	627013	NUT M10 X 1.5 ZINC DIN	4	
35	611149	BOLT M8X1.25X25 FT ZIN	4	
36	682276	NUT W/ FLANGE M8 X 1.2	4	
40	643065	O RING 89.6MM X 5.7MM	4	
41	643015	O RING 15.8MM X 2.4MM	4	
44	804697	MUFFLER 20/25PP NEW	2	
53T	643136	O RING G-55 PTFE	4	
KIT	K40-MT	LIQUID SIDE KIT		
KIT	K45-AM-DP-HD	AIR MOTOR		

Torque Requirements:

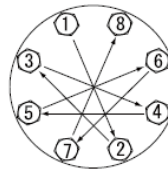

Tightening torque for center rod and out chambers.

Center Rod 43 ft-lbf {60 N-m}  
 Out Chambers 29 ft-lbf {40 N-m}

Tightening torque for manifold retainer bolts.  
 BST 18 ft-lbf {25 N-m}

General Tools:

- Socket wrench - 24mm
- Hexagonal box wrench - 5mm, 6mm
- Open-end wrenches - 19mm, 24mm
- Phillips head screw driver

Special Tools:

- Socket (804129) for a guide to remove the throat bearing (sold separately)

Miscellaneous:

- Assembly Oil - Turbine oil none additional class 1 (equivalent to ISA VGA32 grade)
- Nuts - M16 x 1.5
- Thread locker
- Urea grease grade (NLGI) No. 2, Shell Alvania Grease S1

Customer Notes

Model #: \_\_\_\_\_  
 Description: \_\_\_\_\_  
 Serial #: \_\_\_\_\_  
 Date Installed: \_\_\_\_\_  
 Department Location: \_\_\_\_\_  
 Tag/Project: \_\_\_\_\_