

EXPLODED VIEW & PARTS LISTING

Model: DP-50-HD (XDP)
Aluminum Series



Air Operated Double Diaphragm Pump



Trial Program

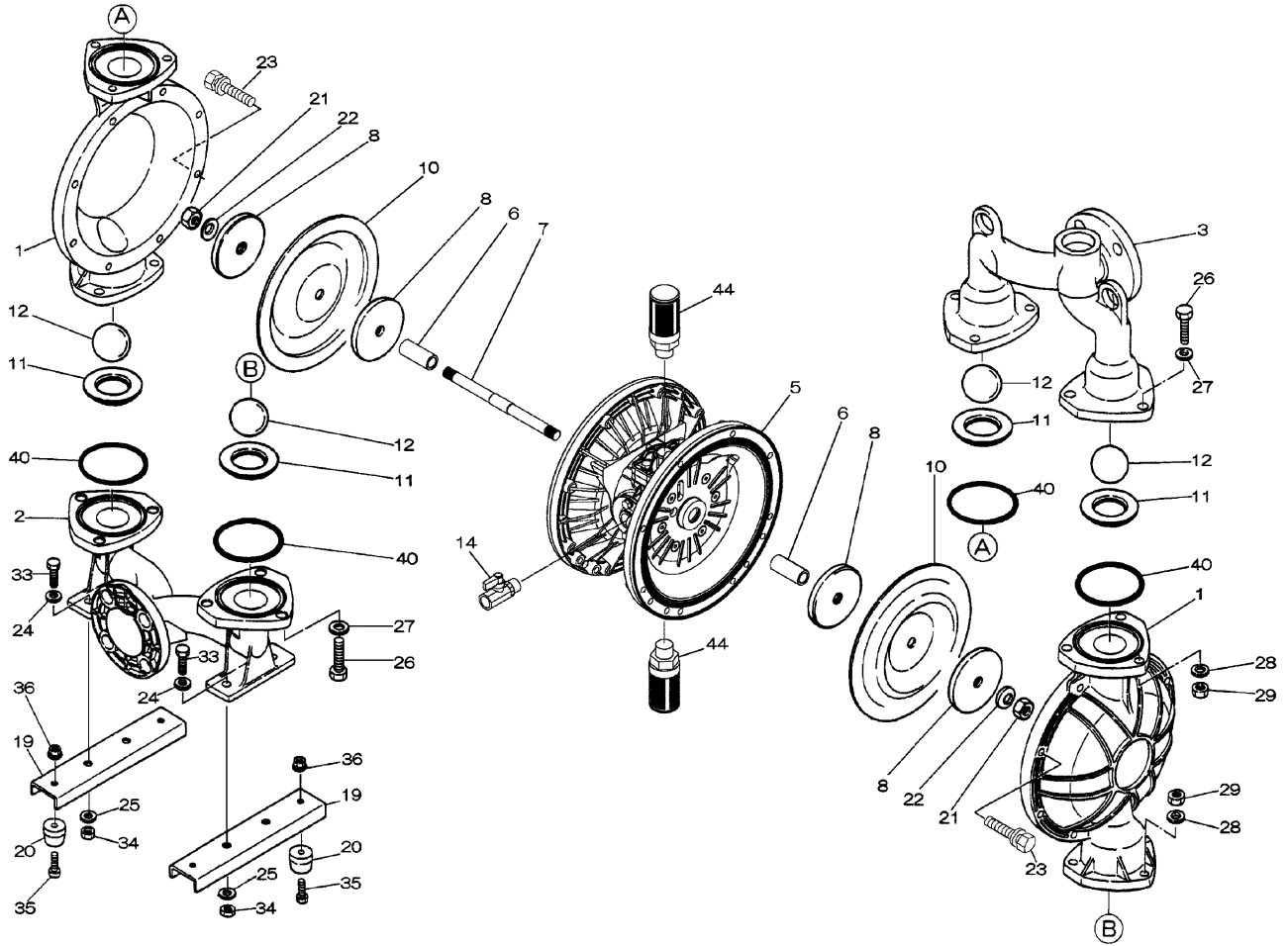

Air Operated Double Diaphragm Pump

804778 Center Body Assembly

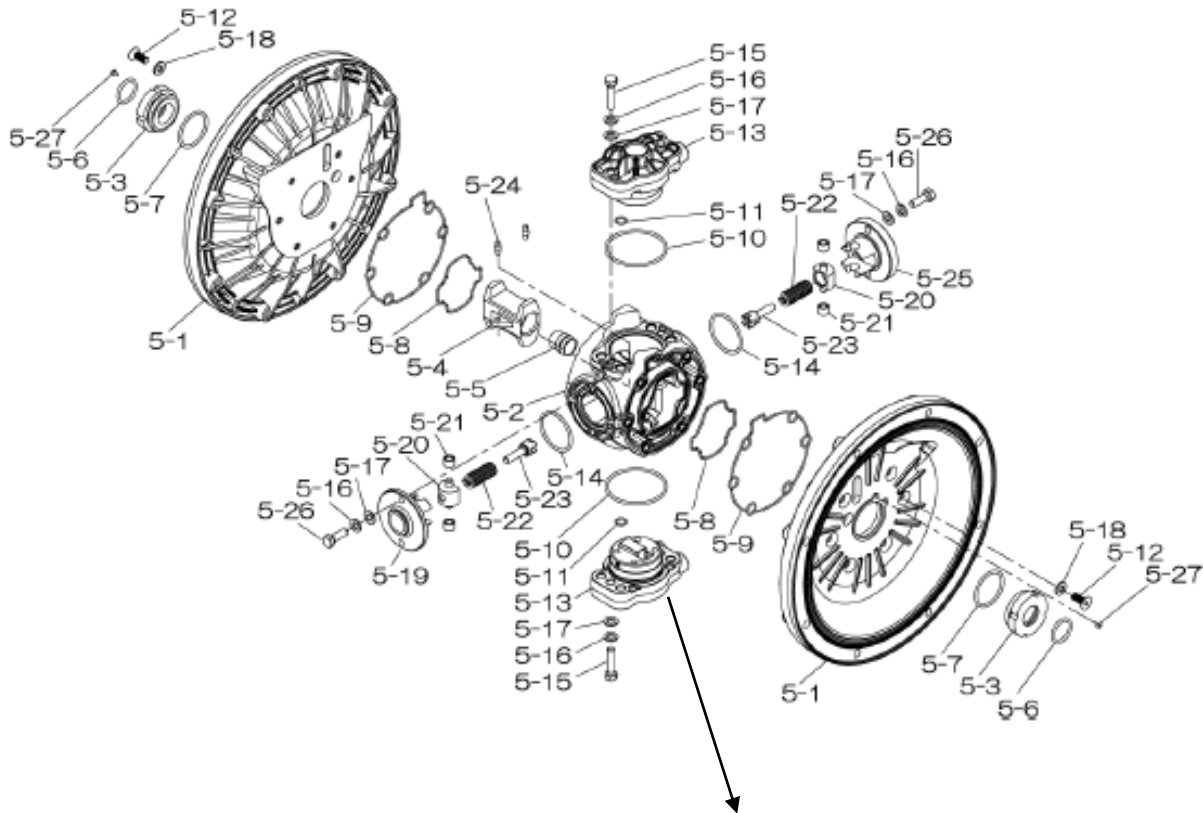

804784 Valve Body Assembly

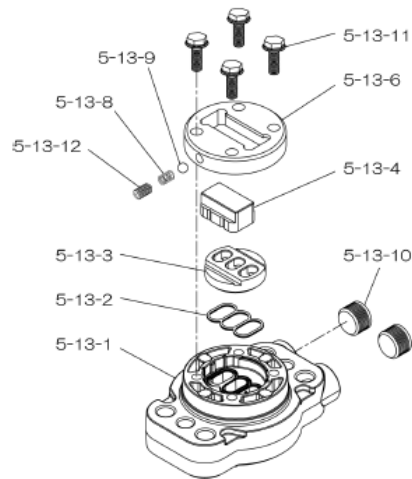

Air Operated Double Diaphragm Pump

	DP-50BAC-HD	DP-50BAN-HD	DP-50BAE-HD	DP-50BAV-HD	DP-50BAH-HD	DP-50BAS-HD			
XDP	854411	854412	854413	854414	854416	854417			
REF. No.	PARTS No.	PARTS No.	PARTS No.	PARTS No.	PARTS No.	PARTS No.	DESCRIPTION	QTY.	REORDER
1	580961	580961	580961	580961	580961	580961	OUT CHAMBER NDP-50AL	2	
2	714369	714369	714369	714369	714369	714369	IN MANIFOLD 50AL	1	
3	714363	714363	714363	714363	714363	714363	OUT MANIFOLD 50AL	1	
5	804778	804778	804778	804778	804778	804778	CENTER BODY ASSY DP-50-HD	1	
5- 1	716247	716247	716247	716247	716247	716247	AIR CHAMBER	2	
5- 2	716256	716256	716256	716256	716256	716256	BODY	1	
5- 3	773048	773048	773048	773048	773048	773048	THROAT BEARING	2	
5- 4	716214	716214	716214	716214	716214	716214	SHUTTLE (CS)	1	
5- 5	773047	773047	773047	773047	773047	773047	CENTER ROD GUIDE	1	
5- 6	640023	640023	640023	640023	640023	640023	O RING 24.6MM X 3.6MM	2	
5- 7	640133	640133	640133	640133	640133	640133	O RING	2	
5- 8	773040	773040	773040	773040	773040	773040	GASKET	2	
5- 9	773041	773041	773041	773041	773041	773041	GASKET	2	
5-10	640138	640138	640138	640138	640138	640138	O RING (64.5X3.0MM)	2	
5-11	640007	640007	640007	640007	640007	640007	O RING 9.5MM X 2.0MM	8	
5-12	683812	683812	683812	683812	683812	683812	M8X1.25X20 FLAT SOCKET	12	
5-13	804784	804784	804784	804784	804784	804784	VALVE BODY ASSY	2	
5-13- 1	716244	716244	716244	716244	716244	716244	VALVE BODY(H40.50.80)	1	
5-13- 2	773042	773042	773042	773042	773042	773042	GASKET	1	
5-13- 3	716246	716246	716246	716246	716246	716246	SEAT (CS)	1	
5-13- 4	773425	773425	773425	773425	773425	773425	BLOCK	1	
5-13- 6	773426	773426	773426	773426	773426	773426	GUIDE PLATE	1	
5-13- 8	706612	706612	706612	706612	706612	706612	SPRING INK	1	
5-13- 9	686271	686271	686271	686271	686271	686271	BALL	1	
5-13-10	772934	772934	772934	772934	772934	772934	PLUG 20/25-PP	2	
5-13-11	602300	602300	602300	602300	602300	602300	TAPPING BOLT M6X1X16	4	
5-13-12	610025	610025	610025	610025	610025	610025	HEX. SOCKET HEAD SCREW	1	
5-14	640134	640134	640134	640134	640134	640134	O RING 44.5MM X 3MM	2	
5-15	611153	611153	611153	611153	611153	611153	BOLT M8X1.25X35 HEX FT	4	
5-16	631420	631420	631420	631420	631420	631420	SPRING WASHER M8 ZINC	8	
5-17	631013	631013	631013	631013	631013	631013	WASHER FLAT M8 ZINC DI	8	
5-18	684987	684987	684987	684987	684987	684987	WASHER 40/50/80 NEW	12	
5-19	716249	716249	716249	716249	716249	716249	RETAINER	1	
5-20	713620	713620	713620	713620	713620	713620	SPRING GUIDE	2	
5-21	773067	773067	773067	773067	773067	773067	BUSH	4	
5-22	684537	684537	684537	684537	684537	684537	SPRING	2	
5-23	714446	714446	714446	714446	714446	714446	TRIP ARM	2	
5-24	700231	700231	700231	700231	700231	700231	PIN	2	
5-25	716216	716216	716216	716216	716216	716216	RETAINER	1	
5-26	611149	611149	611149	611149	611149	611149	BOLT M8X1.25X35 FT ZIN	4	
5-27	686337	686337	686337	686337	686337	686337	TAPPING SCREW	2	
6	716219	716219	716219	716219	716219	716219	CENTER BUSH	2	
7	716218	716218	716218	716218	716218	716218	CENTER ROD	1	
8	711904	711904	711904	711904	711904	711904	CENTER DISK 50-R	4	
10	771855	771702	771856	771800	771703	771976	DIAPHRAGM	2	
11	771957	771995	771949	771987	771794	772004	VALVE SEAT	4	
12	770627	770630	770633	770636	773143	773173	BALL 50 -63MM	4	
14	684322	684322	684322	684322	684322	684322	BALL VALVE 50/80 3/4"	1	
19	711928	711928	711928	711928	711928	711928	BASE 50	2	
20	771402	771402	771402	771402	771402	771402	FOOT RUBBER 40/50/80&2	4	

Air Operated Double Diaphragm Pump

	DP-50BAC-HD	DP-50BAN-HD	DP-50BAE-HD	DP-50BAV-HD	DP-50BAH-HD	DP-50BAS-HD			
REF. No.	PARTS No.	PARTS No.	PARTS No.	PARTS No.	PARTS No.	PARTS No.	DESCRIPTION	QTY.	REORDER
21	683408	683408	683408	683408	683408	683408	M16X1.50 NYLON NUT SS	2	
22	682740	682740	682740	682740	682740	682740	WASHER M16 SS CONICAL	2	
23	686162	686162	686162	686162	686162	686162	BOLT	16	
24	631014	631014	631014	631014	631014	631014	WASHER FLAT M10 ZINC	4	
25	631917	631917	631917	631917	631917	631917	WAVE WASHER M10	20	
26	611203	611203	611203	611203	611203	611203	BOLT M12X1.75X50 ZINC	12	
27	631015	631015	631015	631015	631015	631015	WASHER FLAT M12 ZINC D	12	
28	631918	631918	631918	631918	631918	631918	WAVE WASHER	12	
29	627014	627014	627014	627014	627014	627014	NUT M12X1.75 CT ZINC	12	
33	611175	611175	611175	611175	611175	611175	BOLT M10 X 30 FT ZY	4	
34	627013	627013	627013	627013	627013	627013	NUT M10 X 1.5 ZINC DIN	4	
35	611149	611149	611149	611149	611149	611149	BOLT M8X1.25X25 FT ZIN	4	
36	682276	682276	682276	682276	682276	682276	NUT W/ FLANGE M8 X 1.2	4	
40	640069	640069	684122	642069	640069	684122	O RING 104.3MM X 5.7MM	4	
44	804697	804697	804697	804697	804697	804697	MUFFLER 20/25PP NEW	2	
KIT	K50-MC	K50-MN	K50-ME	K50-MV	K50-MH	K50-MS	LIQUID SIDE		
KIT	K45-AM-DP-HD						AIR MOTOR		

General Tools:

- Socket wrench - 24mm
- Hexagonal box wrench - 5mm, 6mm
- Small crowbars - 2 (B_C, B_N, B_E, B_V)
- Open-end wrenches - 19mm, 24mm
- Phillips head screw driver

Special Tools:

- Socket (804129) for a guide to remove the throat bearing (sold separately)

Miscellaneous:

- Assembly Oil - Turbine oil none additional class 1 (equivalent to ISA VGA32 grade)
- Nuts - M16 x 1.5
- Thread locker
- Urea grease grade (NLGI) No. 2, Shell Alvania Grease S1

Torque Requirements:

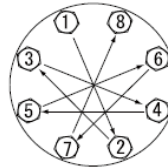

Tightening torque for center rod and out chambers.

Center Rod 43 ft-lbf {60 N-m}
Out Chambers 29 ft-lbf {40 N-m}

Tightening torque for manifold retainer bolts.

BA_ 18 ft-lbf {25 N-m}

Customer Notes

Model #: _____
 Description: _____
 Serial #: _____
 Date Installed: _____
 Department Location: _____
 Tag/Project: _____