

Trial Program

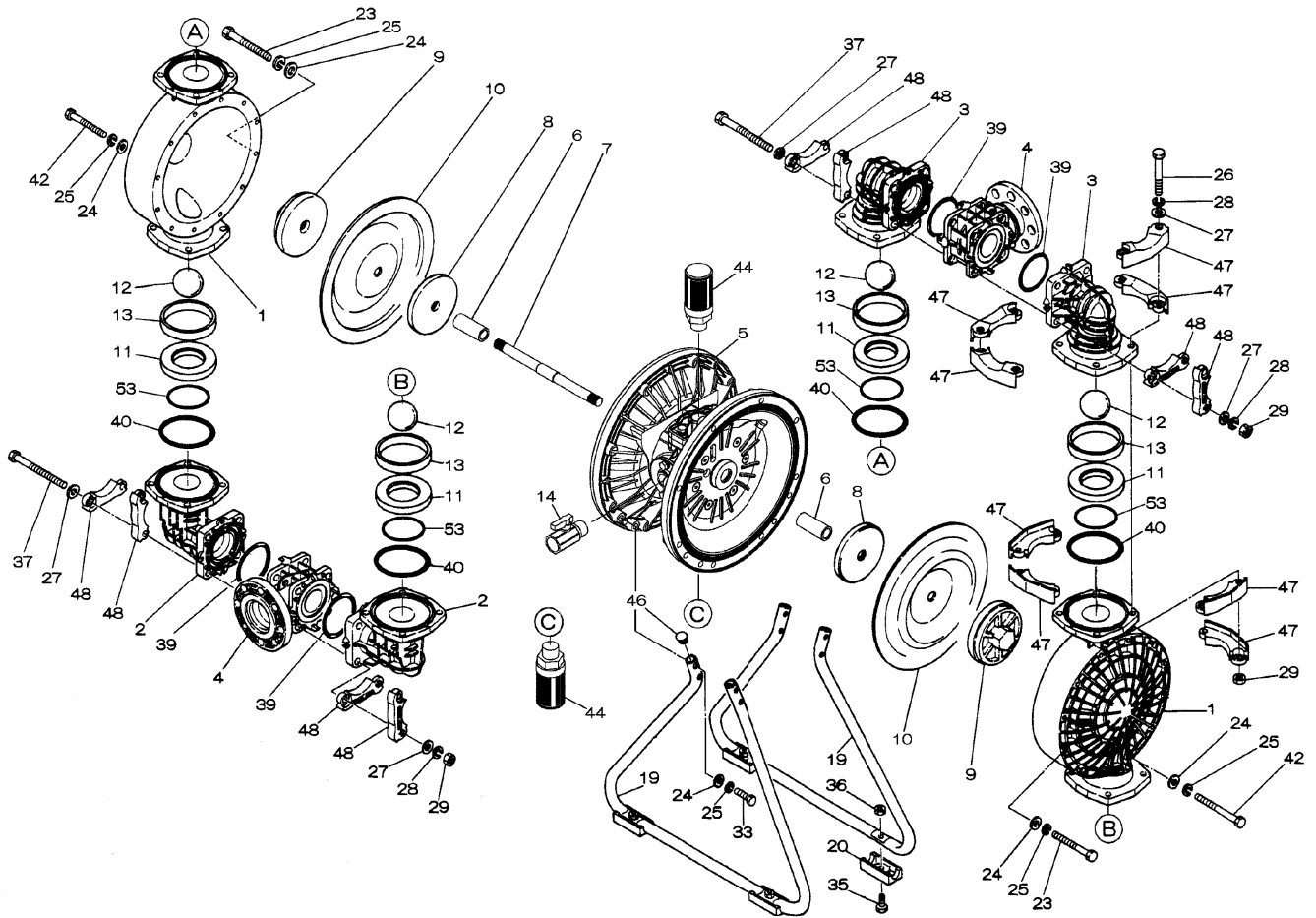

Air Operated Double Diaphragm Pump

804780 Center Body Assembly

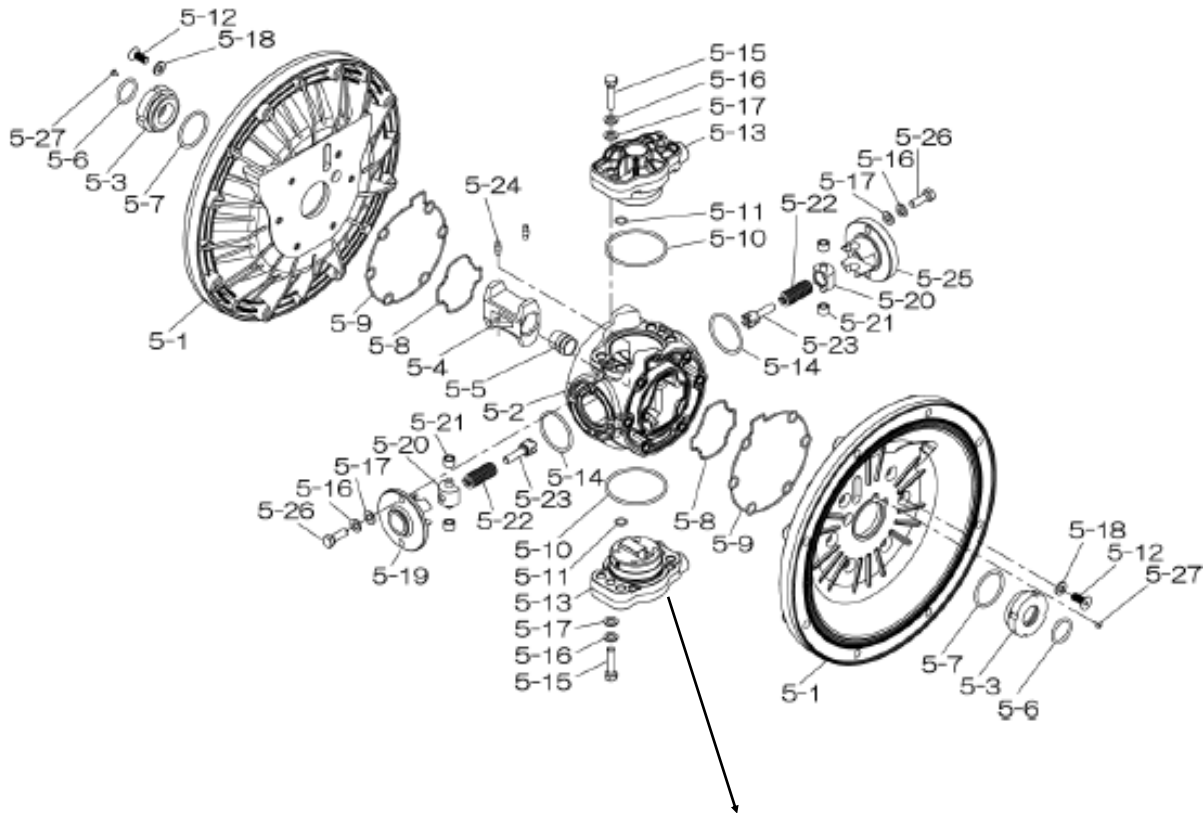

804784 Valve Body Assembly

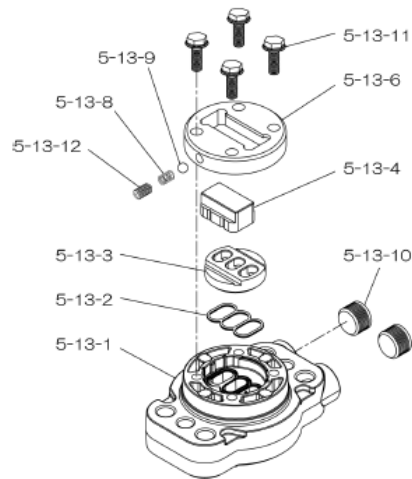

Air Operated Double Diaphragm Pump

	DP-80BPC-HD	DP-80BPS-HD	DP-80BPN-HD	DP-80BPE-HD	DP-80BPH-HD	DP-80BPV-HD		
PARTS LIST	854547	854553	854548	854549	854552	854550		
REF. No.	PARTS No.	PARTS No.	PARTS No.	PARTS No.	PARTS No.	PARTS No.	DESCRIPTION	QTY.
1	780149	780149	780149	780149	780149	780149	OUT CHAMBER 80PP-2	2
2	780246	780246	780246	780246	780246	780246	IN MANIFOLD 80PP	2
3	780152	780152	780152	780152	780152	780152	OUT MANIFOLD 80PP-2	2
4	780250	780250	780250	780250	780250	780250	CENTER MANIFOLD 80PP	2
5	804780	804780	804780	804780	804780	804780	CENTER BODY ASSY DP-80-HD	1
5- 1	716248	716248	716248	716248	716248	716248	AIR CHAMBER	2
5- 2	716256	716256	716256	716256	716256	716256	BODY	1
5- 3	773066	773066	773066	773066	773066	773066	THROAT BEARING	2
5- 4	716214	716214	716214	716214	716214	716214	SHUTTLE (CS)	1
5- 5	773047	773047	773047	773047	773047	773047	CENTER ROD GUIDE	1
5- 6	640023	640023	640023	640023	640023	640023	O RING 24.6MM X 3.6MM	2
5- 7	640133	640133	640133	640133	640133	640133	O RING	2
5- 8	773040	773040	773040	773040	773040	773040	GASKET	2
5- 9	773041	773041	773041	773041	773041	773041	GASKET	2
5-10	640138	640138	640138	640138	640138	640138	O RING (64.5X3.0MM)	2
5-11	640007	640007	640007	640007	640007	640007	O RING 9.5MM X 2.0MM	8
5-12	683812	683812	683812	683812	683812	683812	M8X1.25X20 FLAT SOCKET	12
5-13	804784	804784	804784	804784	804784	804784	VALVE BODY ASSY	2
5-13- 1	716244	716244	716244	716244	716244	716244	VALVE BODY(H40.50.80)	1
5-13- 2	773042	773042	773042	773042	773042	773042	GASKET	1
5-13- 3	716246	716246	716246	716246	716246	716246	SEAT (CS)	1
5-13- 4	773425	773425	773425	773425	773425	773425	BLOCK	1
5-13- 6	773426	773426	773426	773426	773426	773426	GUIDE PLATE	1
5-13- 8	706612	706612	706612	706612	706612	706612	SPRING INK	1
5-13- 9	686271	686271	686271	686271	686271	686271	BALL	1
5-13-10	772934	772934	772934	772934	772934	772934	PLUG 20/25-PP	2
5-13-11	602300	602300	602300	602300	602300	602300	TAPPING BOLT M6X1X16	4
5-13-12	610025	610025	610025	610025	610025	610025	HEX. SOCKET HEAD SCREW	1
5-14	640134	640134	640134	640134	640134	640134	O RING 44.5MM X 3MM	2
5-15	611153	611153	611153	611153	611153	611153	BOLT M8X1.25X35 HEX FT	4
5-16	631420	631420	631420	631420	631420	631420	SPRING WASHER M8 ZINC	8
5-17	631013	631013	631013	631013	631013	631013	WASHER FLAT M8 ZINC DI	8
5-18	684987	684987	684987	684987	684987	684987	WASHER 40/50/80 NEW	12
5-19	716249	716249	716249	716249	716249	716249	RETAINER	1
5-20	713620	713620	713620	713620	713620	713620	SPRING GUIDE	2
5-21	773067	773067	773067	773067	773067	773067	BUSH	4
5-22	686303	686303	686303	686303	686303	686303	SPRING	2
5-23	714446	714446	714446	714446	714446	714446	TRIP ARM	2
5-24	700231	700231	700231	700231	700231	700231	PIN	2
5-25	716216	716216	716216	716216	716216	716216	RETAINER	1
5-26	611149	611149	611149	611149	611149	611149	BOLT M8X1.25X25 FT ZIN	4
5-27	686337	686337	686337	686337	686337	686337	TAPPING SCREW	2
6	716253	716253	716253	716253	716253	716253	CENTER BUSH	2
7	716252	716252	716252	716252	716252	716252	CENTER ROD	1
8	711906	711906	711906	711906	711906	711906	CENTER DISK 80-R	2
9	780064	780064	780064	780064	780064	780064	CENTER DISK 80PP-R	2
10	771857	771977	771704	771858	771705	771801	DIAPHRAGM 80	2
11	772098	772098	772098	772098	772098	772098	VALVE SEAT 80PP-2	4
12	770559	773174	773174	770596	773144	770605	BALL 80	4
13	772099	772099	770587	770587	770587	770587	VALVE SPACER 80PP-2	4
14	684322	684322	684322	684322	684322	684322	BALL VALVE 50/80 3/4"	1
19	711927	711927	711927	711927	711927	711927	STAND 80PP	2
20	771865	771865	771865	771865	771865	771865	FOOT RUBBER 40/50/80 P	4

Air Operated Double Diaphragm Pump

23	683543	683543	683543	683543	683543	683543	BOLT M10X1.50X130 HEX	20
24	631330	631330	631330	631330	631330	631330	WASHER FLAT M10 SS	32
25	680257	680257	680257	680257	680257	680257	SPRING WASHER M10 SS D	32
26	621213	621213	621213	621213	621213	621213	BOLT M12X1.75X100 HEX	16
27	631331	631331	631331	631331	631331	631331	WASHER M12 SS FLAT	32
28	680607	680607	680607	680607	680607	680607	SPRING WASHER M12 SS	24
29	628014	628014	628014	628014	628014	628014	NUT M12X1.75 CT SS DIN	24
33	621179	621179	621179	621179	621179	621179	BOLT M10X1.5X40 HEX FT	8
35	621149	621149	621149	621149	621149	621149	BOLT M8X1.25X25 HET FT	4
36	683837	683837	683837	683837	683837	683837	NUT W/ FLANGE M8 X 1.2	4
37	683544	683544	683544	683544	683544	683544	BOLT M12 X 1.75 X 220	8
39	640070	684123	684123	684123	684123	684123	O RING 109.6 MM X5.7 M	4
40	640080	684125	640080	684125	640080	640080	O RING 149.6 MM X5.7 M	4
42	683552	683552	683552	683552	683552	683552	BOLT M10X1.5X150 PT SS	4
44	804697	804697	804697	804697	804697	804697	MUFFLER 20/25PP NEW	2
46	683641	683641	683641	683641	683641	683641	CAP 40/50/80PP STAND	4
47	771789	771789	771789	771789	771789	771789	PROTECTOR A 80PP	32
48	771790	771790	771790	771790	771790	771790	PROTECTOR B 80PP	24
53	640143	685443	640143	685443	640143	642143	O RING	4
KIT	K80-PC	K80-PS	K80-PN	K80-PE	K80-PH	K80-PV	LIQUID SIDE	
KIT	K80-AM-DP-HD						AIR MOTOR	

General Tools:

- Socket wrench - 24mm
- Hexagonal box wrench - 5mm, 6mm
- Small crowbars - 2 (B_C, B_N, B_E, B_V)
- Open-end wrenches - 19mm, 24mm
- Phillips head screw driver

Special Tools:

- Socket (804129) for a guide to remove the throat bearing (sold separately)
- PP Wrench (771868) sold separately. For removing the center disk on BP_ and BV_ types

Miscellaneous:

- Assembly Oil - Turbine oil none additional class 1 (equivalent to ISA VGA32 grade)
- Nuts - M16 x 1.5
- Thread locker
- Urea grease grade (NLGI) No. 2, Shell Alvania Grease S1

Torque Requirements:

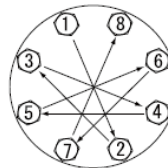

Tightening torque for center rod and out chambers.

- Center Rod 36 ft-lbf {60 N-m}
- Out Chambers 26 ft-lbf {40 N-m}

Tightening torque for manifold retainer bolts.

- BP_ 18 ft-lbf {25 N-m}

Customer Notes

Model #: _____
 Description: _____
 Serial #: _____
 Date Installed: _____
 Department Location: _____
 Tag/Project: _____